



APPROVALS



ENGINEERING CODE
513306045

APPROVED REFRIGERANT
R-134a

POWER SUPPLY
220-240 V 50 Hz

STANDARD CONDITIONS
EN12900

APPLICATION
HBP

COOLING CAPACITY
371 W (HBP)

EFFICIENCY
2.47 W/W (HBP)

MOTOR TYPE
CSIR

STARTING TORQUE
HST

DATA

General Data

Type	Hermetic reciprocating
Technology Type	On-Off
Displacement	3.97 cm ³
Compressor Cooling	Static/NotControlled/220
Expansion Device	Capillary Tube or Expansion Valve
Horse Power	1/7 hp
Power Supply	220-240 V 50 Hz
Evaporating Temperature Range	-15 °C to 10 °C

Electrical Data

Motor type	CSIR
Starting Torque	HST
Start Winding Resistance	18.1 Ω at 25° C
Run Winding Resistance	16.25 Ω at 25° C
Rated Load Amperage (RLA) at 50 Hz	1.35 A

Mechanical Data

Oil Charge	180 ml
Oil Type Configuration	ESTER
Oil Type Viscosity	ISO22
Weight	7.52 Kg

Electrical Components

	Description
Starting Device	Relay MTRP-0036*
Start Capacitor	64-77 Uf / 280 V
Motor Protection	T0043/G5

External Characteristics

Tray Holder	Yes	
Connector	Internal Diameter	Shape
Suction	6.1 mm	Slanted 42° up + 45° to Back/Copper
Discharge	4.94 mm	Slanted parallel BP+24° to Back/Copper
Process	6.1 mm	Slanted 45° up + 45° to Back/Copper

PERFORMANCE

Rated Points

Condensing Temperature	Evaporating Temperature	Cooling Capacity	Power Consumption	Gas Flow Rate	Efficiency
50.00°C	5.00°C	371 W	150 W	9.35 kg/h	2.47 W/W

Test Condition: EN12900HBP, Static/NotControlled/220, Return Gas 20°C, Evaporation 5.00°C, Condensing 50.00°C, Ambient 35°C, Liquid 50°C, Subcooling OK. Data are an indication of performance based simulation.

Performance Curve Data

Condensing Temperature 35°C

Evaporating Temperature °C	Cooling Capacity W	Power W	Gas Flow Rate kg/h	Efficiency W/W
-15	195	98	4.14	2
-10	244	106	5.18	2.3
-5	301	113	6.43	2.65
0	368	120	7.92	3.08
5	448	125	9.71	3.58
10	542	131	11.86	4.14

Test Condition: EN12900HBP, Static/NotControlled/220, Return Gas 20°C, Ambient 35°C , Subcooling 0K. Data are an indication of performance based simulation.

Condensing Temperature 45°C

Evaporating Temperature °C	Cooling Capacity W	Power W	Gas Flow Rate kg/h	Efficiency W/W
-15	170	101	3.94	1.68
-10	213	112	4.97	1.9
-5	265	122	6.21	2.17
0	326	131	7.69	2.49
5	398	140	9.48	2.85
10	484	148	11.63	3.26

Test Condition: EN12900HBP, Static/NotControlled/220, Return Gas 20°C, Ambient 35°C , Subcooling 0K. Data are an indication of performance based simulation.

Condensing Temperature 55°C

Evaporating Temperature °C	Cooling Capacity W	Power W	Gas Flow Rate kg/h	Efficiency W/W
-15	144	107	3.73	1.35
-10	183	119	4.75	1.53
-5	229	131	5.97	1.75
0	283	142	7.44	1.99
5	347	153	9.22	2.27
10	424	164	11.36	2.59

Test Condition: EN12900HBP, Static/NotControlled/220, Return Gas 20°C, Ambient 35°C , Subcooling 0K. Data are an indication of performance based simulation.

Operating Envelope

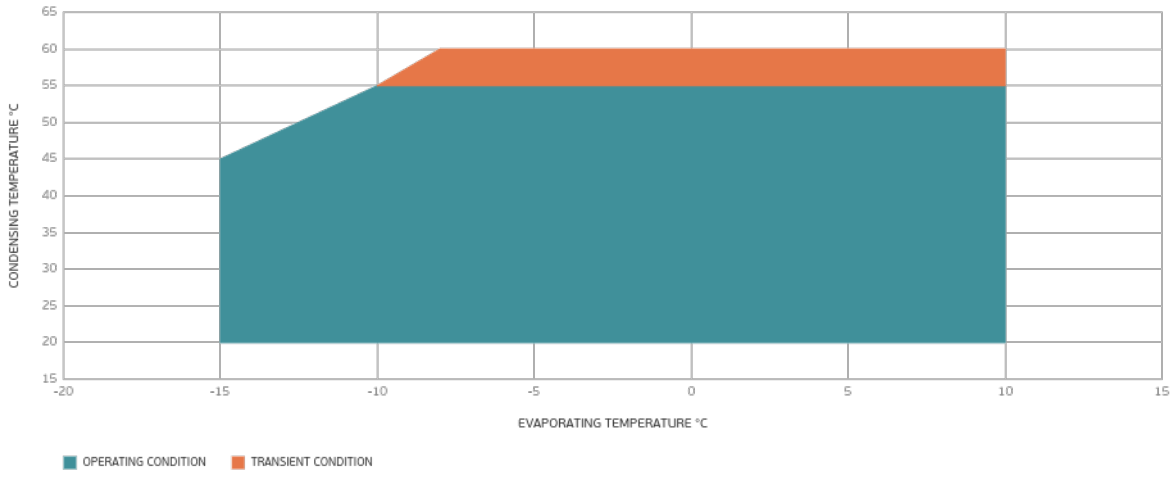

External Dimensions

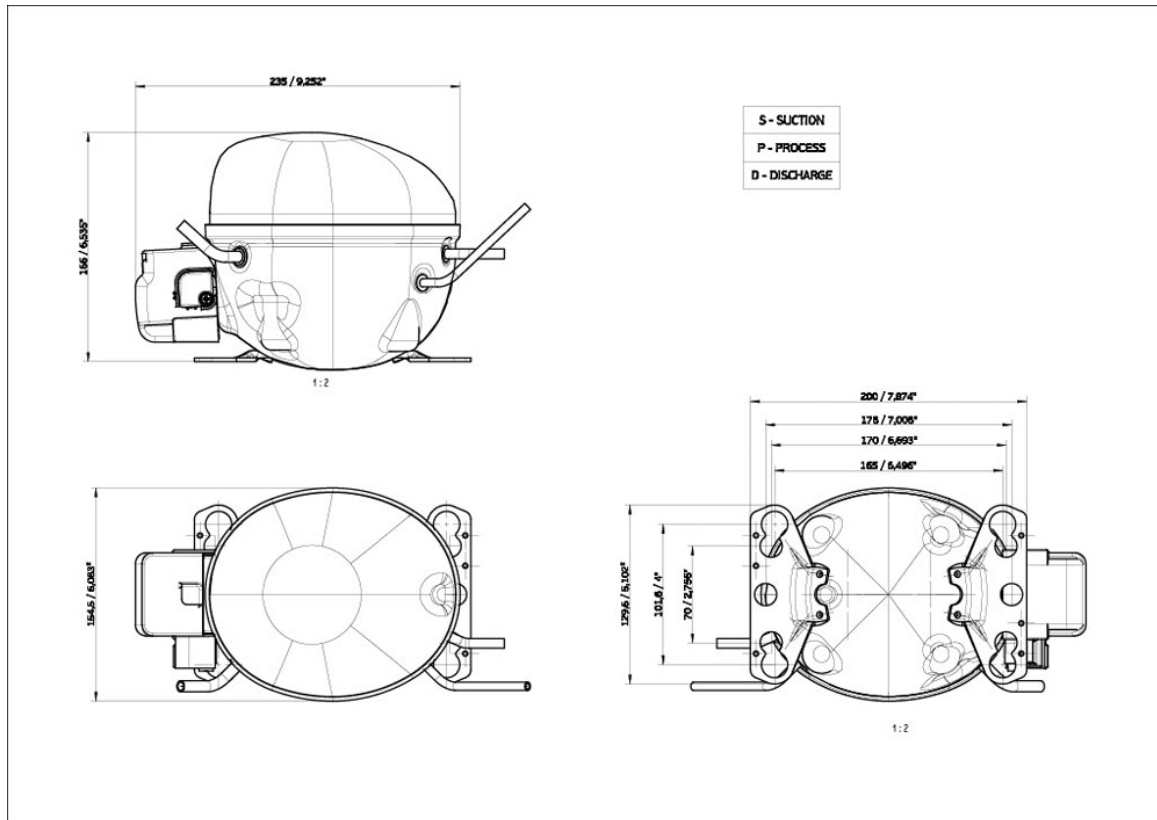

Wiring Diagram

SM28-4

