



Model: EMT49HLP
Code: 192EA47

embraco POWER IN.
CHANGE ON

Type:	On-off
Voltage [V] / Frequency [Hz] / Phases	220-240 V 50 Hz 1 ~
Refrigerant:	R-134a
Application:	LBP

Motor type:	RSIR
Starting torque:	LST
HP:	
Displacement:	5.56 cm ³

OPERATING CONDITION : ASHRAE LBP 32

Evaporation Temp.	-23.3 °C	Return Temp.	32.2 °C	Superheating	55.5 K
Condensing Temp.	54.4 °C	Liquid Temp.	32.2 °C	Subcooling	22.2 K

Cooling capacity	Power consumption	Mass flow rate	Efficiency
151.05 W	112.67 W	2.93 kg/h	1.34 W/W

APPLICATION

Evaporating temperature range:	-30 to -5 °C	Cooling type:	Static
Permanent operating temperature (peak) :	60 (70) °C	Air Flow	--
Expansion device:	Capillary tube	Maximum motor temperature:	130 °C

ELECTRICAL DATA

Start winding resistance at 25°C (77°F):	34.5 Ω +/- 8%	Run winding resistance at 25°C (77°F):	18.5 Ω +/- 8%
FLA - full load amperage L/MBP [A] 50 Hz / 60 Hz:	- / -	LRA (A) 50 Hz / 60 Hz:	- / -
		FLA - full load amperage HBP [A] 50 Hz / 60 Hz:	- / -

MECHANICAL DATA

Bore:	22.5 mm	Stroke:	7 mm
		Displacement:	5.56 cm ³

OTHER INFORMATION

Weight:	7.71 kg	Oil charge:	180 ml
Lubricant type:	Polyolester ISO22	Nitrogen charge:	No

EXTERNAL SETTINGS

	Shape	Material	Diameter [mm]
Suction connector	Slanted 42°	Copper	6.10
Discharge connector	Slanted parallel to Base Plate	Copper	4.94
Process connector	Slanted 42°	Copper	6.10
Base plate:	European Standard	Tray holder:	Yes

PERFORMANCES AT STANDARD CHECK-POINTS

Checkpoint	Cooling capacity	Power consumption	Gas flow rate	Cooling Efficiency	Heating capacity +/-	Heating Efficiency
	+/-5% W	+/-5% W	+/-5% kg/h	+/- 7% W/W	5% * W	+/- 7% W/W
ARI LBP	126.63	119.53	3.33	1.06	179.74	1.50
ARI MBP	286.44	187.45	7.68	1.53	367.84	1.96
ASHRAE CBP	304.74	175.93	6.64	1.73	391.86	2.23
ASHRAE LBP 32	151.05	112.67	2.93	1.34	206.33	1.83
CECOMAF LBP	111.49	107.14	2.66	1.04	163.71	1.53
EN12900 MBP**	276.18	152.09	6.03	1.82	350.47	2.30

* Calculations performed considering isentropic compression and a housing loss of 10%. This is an estimated heat amount discarded in the discharge pipe and the condenser combined.

CONDENSING TEMP. 35 °C**(SUBCOOLING : 22.2 K, RETURN TEMP.: 32 °C)**

Evaporating temperature °C	Cooling capacity	Power consumption	Gas flow rate	Cooling Efficiency	Heating capacity +/-	Heating Efficiency
	+/-5%	+/-5%	+/-5%	+/- 7%	5% *	+/- 7%
	W	W	kg/h	W/W	W	W/W
-30.00	135.01	86.71	2.28	1.56	174.95	2.02
-25.00	176.58	98.26	2.98	1.80	222.99	2.27
-20.00	228.76	110.82	3.87	2.06	281.87	2.54
-15.00	293.38	123.85	4.98	2.37	353.08	2.85
-10.00	372.15	136.50	6.34	2.73	437.88	3.21
-5.00	466.85	147.70	7.98	3.16	537.57	3.64

CONDENSING TEMP. 45 °C**(SUBCOOLING : 22.2 K, RETURN TEMP.: 32 °C)**

Evaporating temperature °C	Cooling capacity	Power consumption	Gas flow rate	Cooling Efficiency	Heating capacity +/-	Heating Efficiency
	+/-5%	+/-5%	+/-5%	+/- 7%	5% *	+/- 7%
	W	W	kg/h	W/W	W	W/W
-30.00	119.16	90.20	2.15	1.32	161.52	1.79
-25.00	156.61	103.77	2.83	1.51	206.63	1.99
-20.00	202.77	118.70	3.68	1.71	260.70	2.20
-15.00	260.13	134.98	4.73	1.93	326.25	2.42
-10.00	330.67	152.09	6.03	2.17	404.96	2.66
-5.00	416.19	169.15	7.62	2.46	498.18	2.95

CONDENSING TEMP. 55 °C**(SUBCOOLING : 22.2 K, RETURN TEMP.: 32 °C)**

Evaporating temperature °C	Cooling capacity	Power consumption	Gas flow rate	Cooling Efficiency	Heating capacity +/-	Heating Efficiency
	+/-5%	+/-5%	+/-5%	+/- 7%	5% *	+/- 7%
	W	W	kg/h	W/W	W	W/W
-30.00	99.70	90.08	1.94	1.11	141.85	1.57
-25.00	136.36	107.14	2.66	1.27	188.58	1.76
-20.00	177.86	124.47	3.48	1.43	239.35	1.92
-15.00	228.30	143.38	4.48	1.59	299.29	2.09
-10.00	290.40	164.06	5.71	1.77	371.22	2.26
-5.00	366.23	186.00	7.24	1.97	456.98	2.46

ELECTRICAL ACCESSORIES

Kit:	4
Starter device:	PTC
Engineering code:	V230
Run capacitor:	--
Starting capacitor:	--

Thermal protector: T0222-26**Institutes approved for this electric kit:**

If purchased without electricals consult Embraco to verify the supplier of electricals approved for this compressor

MECHANICAL ACCESSORIES**Rubber damper:** Yes**Metal bushing:** Optional

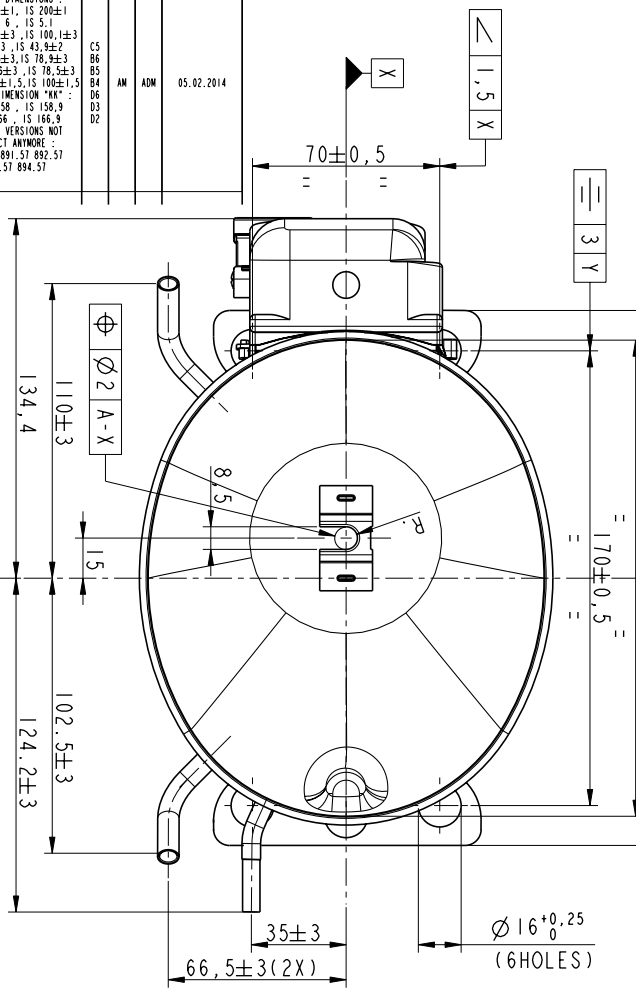
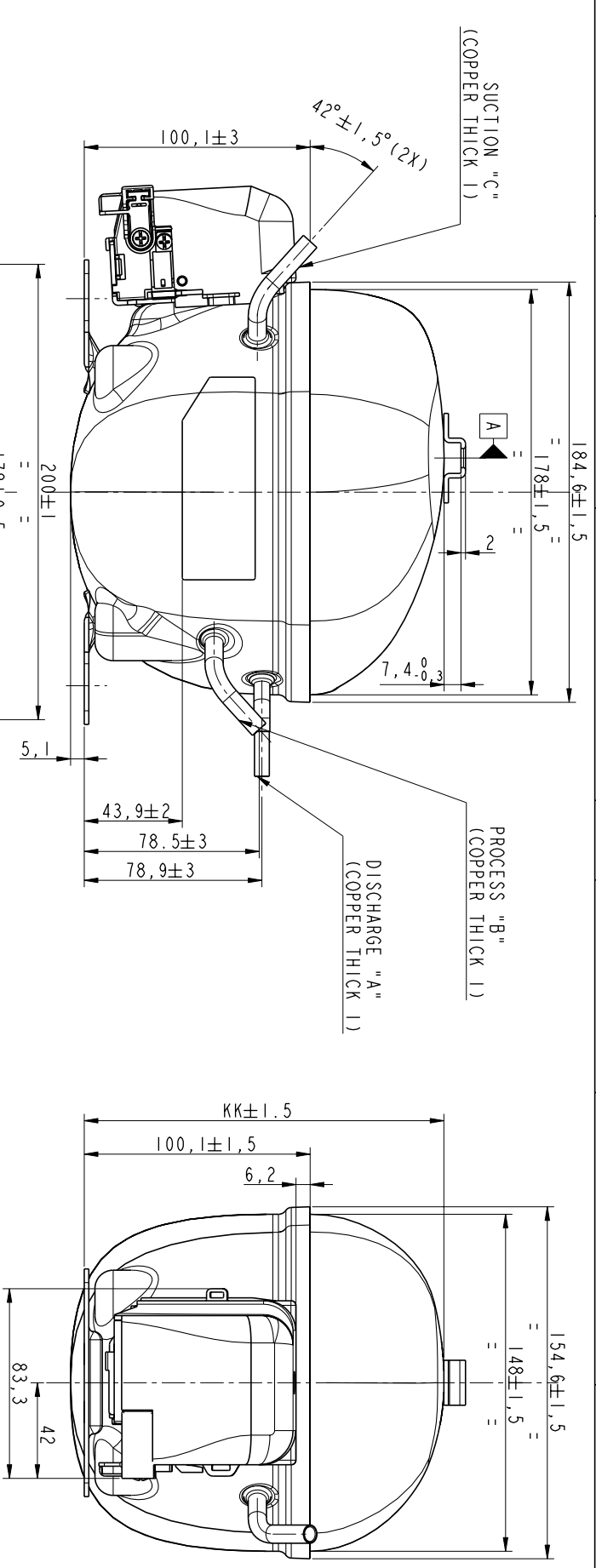

ECM	REVISION	LO	BY	APP	DATE
508261	1	..	FB	ADM	01.08.2006
32441	2	..	AM	ADM	05.02.2014

REVISIONATO:
AGGIUNTI MODELLI
STANDARDIZZATI

CHANGED BASE PLATE.
CHANGED DIMENSIONS:
- WAS 20±1, IS 200±1
- WAS 6 - IS 5,1
- WAS 99,2±3, IS 100,1±3
- WAS 43, IS 43,9±2
- WAS 78±3, IS 78,9±3
- WAS 77,6±3, IS 78,5±3
- WAS 99,2±1,5, IS 100±1,5
CHANGED DIMENSION "KK"
- WAS 158 - IS 158,9
- WAS 166 - IS 166,9
DELETED VERSIONS NOT
PRODUCT ANYMORE
193.47.891.57.892.57
893.57.894.57

CODE	158,9	166,9	166,9	166,9
158,9	166,9	166,9	166,9	166,9
4.86-5.02 X 15 DEEP	6.1-6.2 X 15 DEEP	6.1-6.2 X 15 DEEP	6.1-6.2 X 15 DEEP	6.1-6.2 X 15 DEEP
EMZ/X20CLC	EMZ/X26CLC	EMZ/X26CLC	EMZ/X26CLC	EMZ/X26CLC
EMZ/X26CLC	EMZ/X26CLC	EMZ/X26CLC	EMZ/X26CLC	EMZ/X26CLC
EMZ/X32CLC	EMZ/X32CLC	EMZ/X32CLC	EMZ/X32CLC	EMZ/X32CLC
EMZ/X40CLC	EMZ/X40CLC	EMZ/X40CLC	EMZ/X40CLC	EMZ/X40CLC
EMZ/X46CLC	EMZ/X46CLC	EMZ/X46CLC	EMZ/X46CLC	EMZ/X46CLC
EMZ55CLC	EMZ55CLC	EMZ55CLC	EMZ55CLC	EMZ55CLC
EMT26CLP	EMT26CLP	EMT26CLP	EMT26CLP	EMT26CLP
EMT32CLP	EMT32CLP	EMT32CLP	EMT32CLP	EMT32CLP
EMT40CLP	EMT40CLP	EMT40CLP	EMT40CLP	EMT40CLP
EMT46CLP	EMT46CLP	EMT46CLP	EMT46CLP	EMT46CLP
EMT30CDP	EMT30CDP	EMT30CDP	EMT30CDP	EMT30CDP
EMU26CLC	EMU26CLC	EMU26CLC	EMU26CLC	EMU26CLC
EMU32CLC	EMU32CLC	EMU32CLC	EMU32CLC	EMU32CLC
EMU40CLC	EMU40CLC	EMU40CLC	EMU40CLC	EMU40CLC
EMU46CLC	EMU46CLC	EMU46CLC	EMU46CLC	EMU46CLC
EMT22HLP	EMT22HLP	EMT22HLP	EMT22HLP	EMT22HLP
EMT22HHR	EMT22HHR	EMT22HHR	EMT22HHR	EMT22HHR
EMU32CLC	EMU32CLC	EMU32CLC	EMU32CLC	EMU32CLC
EMT30HHR	EMT30HHR	EMT30HHR	EMT30HHR	EMT30HHR
EMT37HDP	EMT37HDP	EMT37HDP	EMT37HDP	EMT37HDP



DRAWN : N. PREZIOSO 26.10.2004
APP. : A. DE MARTIIS 26.10.2004
ECM : 503342

NAME
VISTA ESTERNA EM REDESIGN / EMS
EXTERNAL VIEW EMS COMPRESSORS
191.47.192.47.194.47.193.67.194.67
893.77.896.77.897.77.898.77

GEN. TOL. :
ANG. TOL. :
SCALE : 1 : 2
REPLACE

No. 1.960.873



6 5 4 3 2 1