

European HVAC Technical Book

—
2024/25

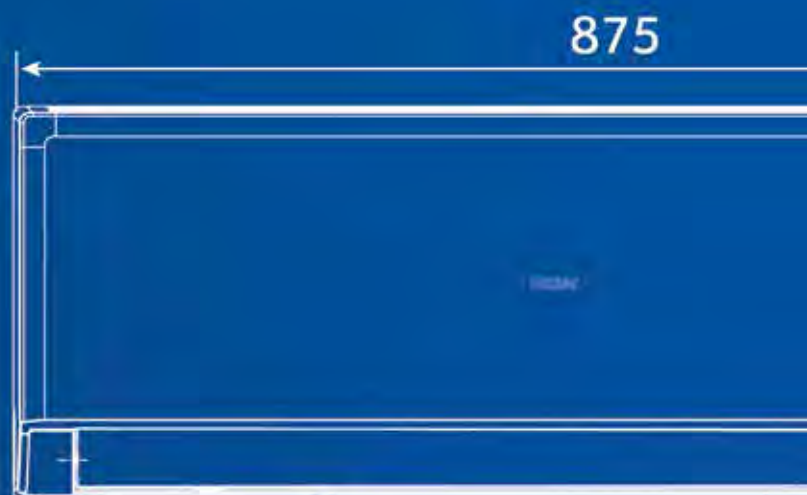
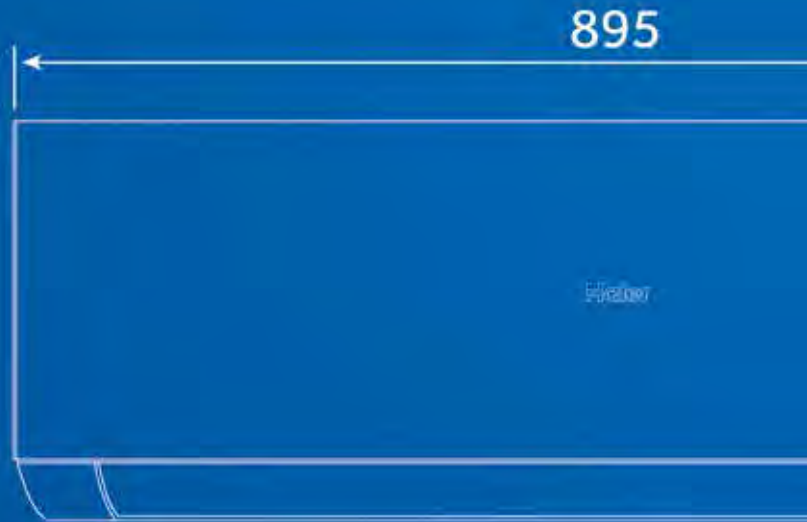
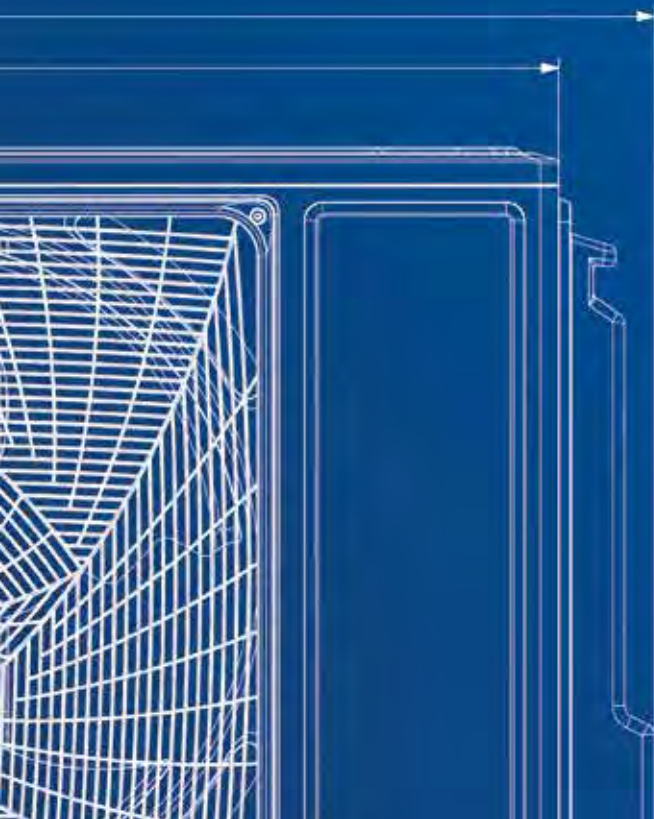

The data in this catalogue is purely indicative as the data may vary. Please be advised to check the accuracy of the data with the supplier before purchasing products.

The Inverter Air Conditioner Guarantee expires if a Class A differential magnetothermal circuit breaker is not installed.

INTRODUCTION	4
WHERE TO READ THE SERIAL NUMBER	12
WHERE TO READ ERROR CODES	13
TROUBLESHOOTING REQUIREMENTS	16
DIAGNOSTIC	28
MONO SPLIT UNITS	36
Pearl R290	39
Expert Nordic	44
Pearl Nordic	47
Flair	49
Ducted High Pressure R32	52
Ducted High Pressure R410A	53
AHU Solution	57
Tower	60
Cabinet	63
MONO SPLIT & MULTI SPLIT UNITS	66
Jade Supermatch	68
Expert Black/White	71
Flexi Plus Black/White	74
Pearl Premium	77
Revive Plus	81
Console	85
1-Way Cassette	89
Cassette 620	91
Round Flow Cassette	93
Ceiling Floor	97
Slim Duct Low Pressure	101
Ducted Medium Pressure	105
OUTDOOR UNITS	114
3S Tank	114
Supermatch Mono R32	116
Supermatch Multi R32	129
Supermatch Mono R410A	139
Maxi Split R32	146
CENTRALISED CONTROLLER	152
TEMPERATURE PROBES	168

Reference conditions: cooling

Ambient temperature: 27°C BS
 19.5°C BU
 Outdoor temperature: 35°C BS

Reference conditions: heating

Ambient temperature: 20°C BS
 Outdoor temperature: 7°C BS

**Energy Efficiency according to EN 14825.
 Performance testing according to EN 14511.**

OUTDOOR UNIT INSTALLATION

Check the dimensions and distances indicated in the installation manual when installing the outdoor unit.

- Position.** The outdoor unit must be installed on a completely horizontal base that is flush with the floor. The base must be level with the floor.
- Dampers / shock absorbers.** Select shock absorbers appropriate to the unit's weight and characteristics. The transmission of noise or vibration through the floor, ceiling or wall is prevented by the correct selection of shock absorbers.

Optional parts for piping

- (A) Non-adhesive tape
- (B) Adhesive tape
- (C) Saddle (L.S) with screws
- (D) Connecting electric cable for indoor and outdoor
- (E) Drain hose
- (F) Heating insulating material
- (G) Piping hole cover

- The marks from A to G in the figure are the parts numbers.
- The distance between the indoor unit and the floor should be more than 2m.

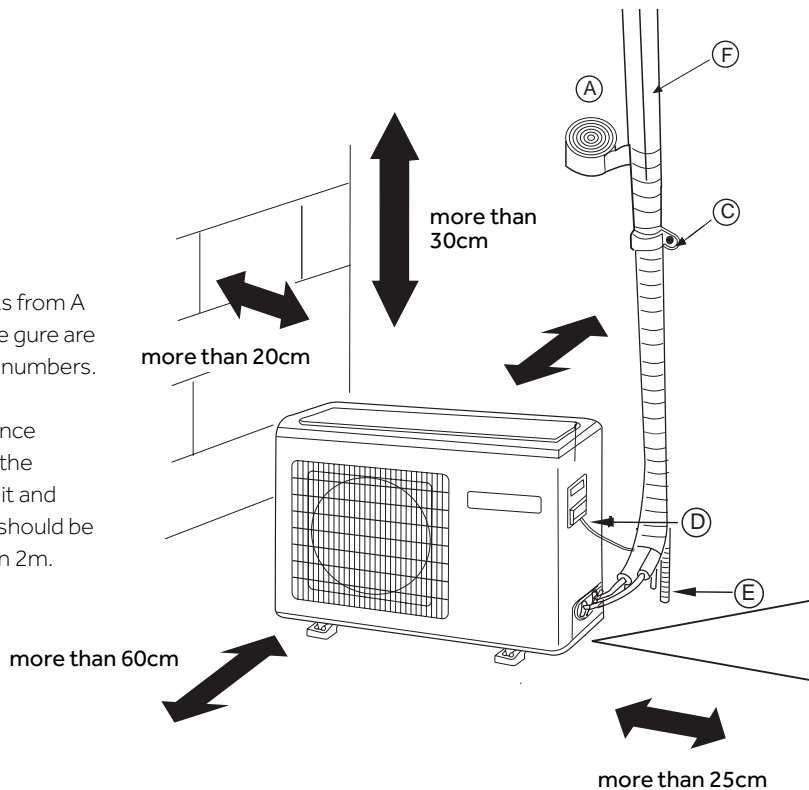

Fixing of outdoor unit

- Fix the unit to concrete or block with bolts (10mm) and nuts firmly and horizontally.
- When fitting the unit to wall surface, roof or rooftop, use a supporter surely with nails or wires in consideration of earthquake and strong wind.
- If vibration may affect the house, fix the unit by attaching a vibration-proof mat.

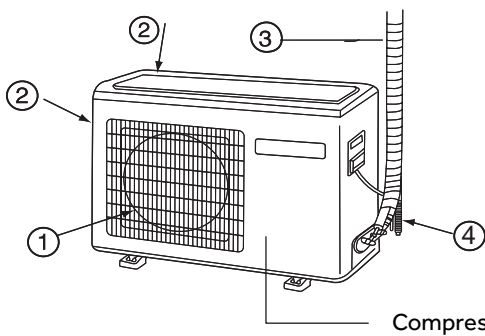

- (1) AIR OUTLET
- (2) AIR INLET
- (3) CONNECTING PIPING AND ELECTRICAL WIRING
- (4) DRAIN HOSE

INDOOR UNIT INSTALLATION

Wall-mounted or Split units

Ensure that the clearances specified in the installation instructions are maintained.

This ensures that the unit is properly ventilated and avoids possible operational problems, which tend to occur during the winter.

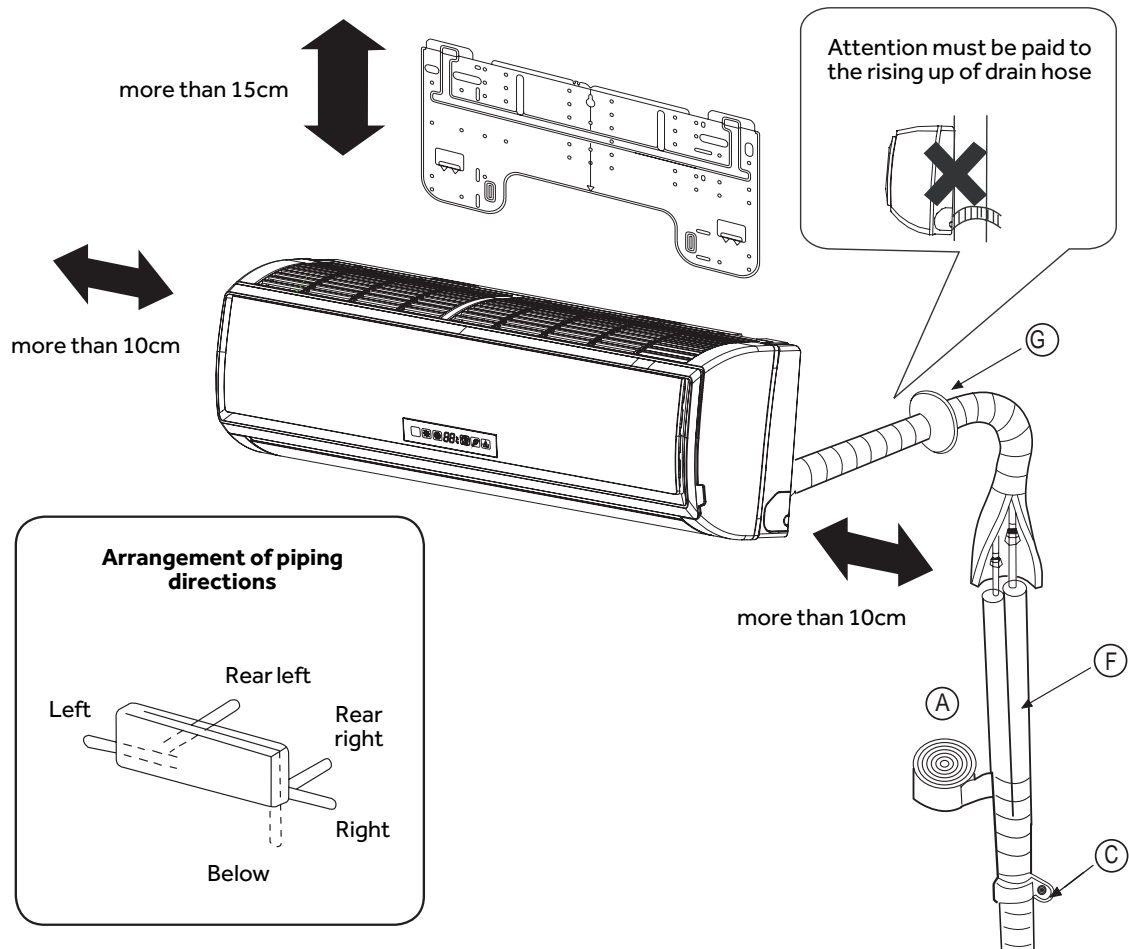

Duct Units

For this type of unit, in addition to the dimensions of the unit in relation to the space in which it is to be installed, it is necessary to take into account the free spaces to allow access for the connection of the refrigerant pipes and the drainage; lack of space can lead to excessive handling of the pipes, which can cause constriction of the pipes and difficulty in tightening the union nuts.

If the ceiling in which the indoor unit is installed is fixed, a door needs to be provided to allow accessing:

- Electrical connections
- Refrigerant connections
- Drain
- Maintenance

PRE-INSTALLATION OF THE REFRIGERATION SYSTEM / PRE-INSTALL COOLING

If pre-installed, the refrigerant pipe section must correspond to the section indicated in the installation manual of the unit to be installed.

Only use the refrigerant pipe sections specified in the installation instructions.

Check that the minimum, maximum and vertical distances are as specified in the Operating Instructions.

The minimum length of the installation must not be less than 3 m.

Outdoor Unit			Amax	Bmax	Bmin
1U25YEMFRA	1U25BEEFRA	1U25YEGFRA-1	10	20	3
1U35YEGFRA	1U35UEEFRA	1U35YEGFRA-1			
1U35YEMFRA	1U20YEEFRA	1U25YEFFRA-1			
1U25YEFFRA-C	1U25YEEFRA	1U35MEEFRA-1			
1U35YEGFRA-2	1U25YEGFRA				
1U25S2SM1FA	1U2SMECFRA-3	1U25S2SM1FA-2	10	20	3
1U35S2SM1FA	1U35MECFRA-3	1U35S2SM1FA-2			
1U42S2SM1FA	1U35YEFFRA-C	1U42S2SM1FA-2			
1U25YEMFRA-UZ	1U35MEEFRA-UZ	1U35S2SM1FA-UZ			
1U25YERFRA	1U35YERFRA				
1U5CMEEFRA	1U68REEFRA	1U50MEMFRA-C	15	25	3
1U50MEGFRA	1U68REMFRA	1U68RENFRA-C			
1U50MEMFRA	1U68RENFRA	1U50JECFRA-3			
1U50S2SJ2FA		1U68WEGFRA			
1U68MRAFRA		1U68WEGFRA-C			
1U50KEFFRA-1	1U50S2SJ2FA-2	1U50MERFRA	15	20	3

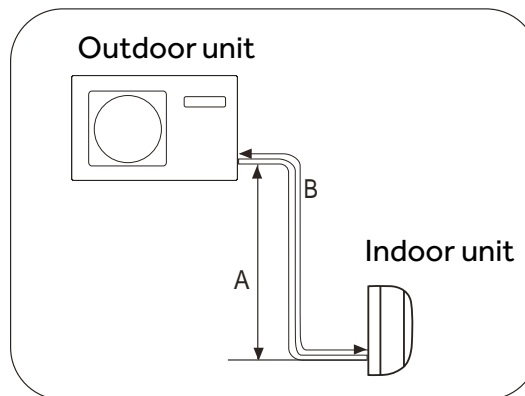
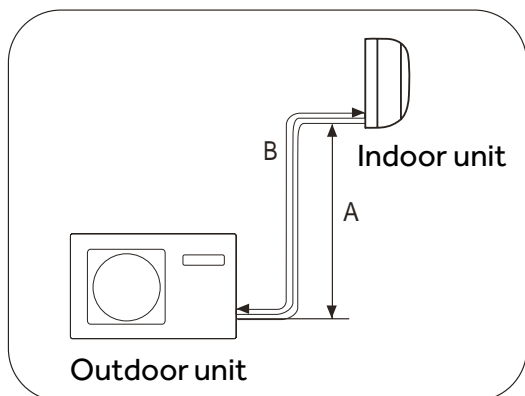

REFRIGERATION CIRCUIT WELDING

Where welding is required on the refrigerant pipe connection.

This type of welding requires a minimum flow of dry nitrogen to circulate through the pipe as heat is applied to the joint.

This nitrogen flow displaces oxygen and creates an internal oxygen-free area. This prevents the formation of scale in the weld zone.

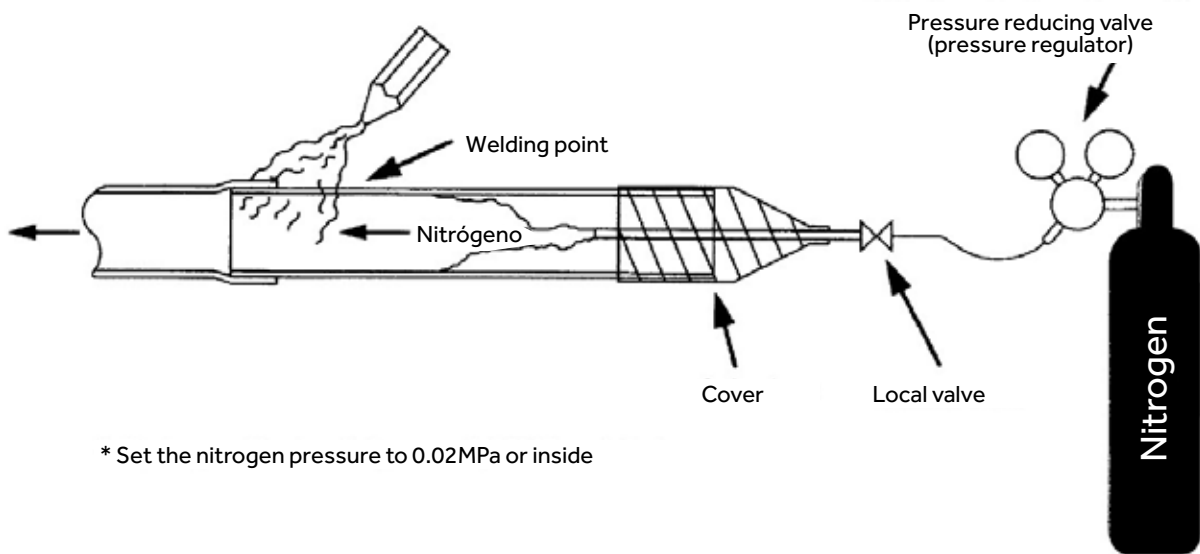

REFRIGERATOR CONNECTION

Flared

The flaring operation consists of connecting the refrigerant line to the unit.

To avoid refrigerant leakage, this operation must be carried out with great precision.

Fastening / Tighten

It is recommended that a torque wrench is used for accurate torque application or if a torque wrench is not available, a socket wrench should be used.

To avoid twisting in the pipes, it is essential to use 2 tightening tools.

The use of inappropriate tightening tools can result in excessive torque. This can cause thread and flare defects.

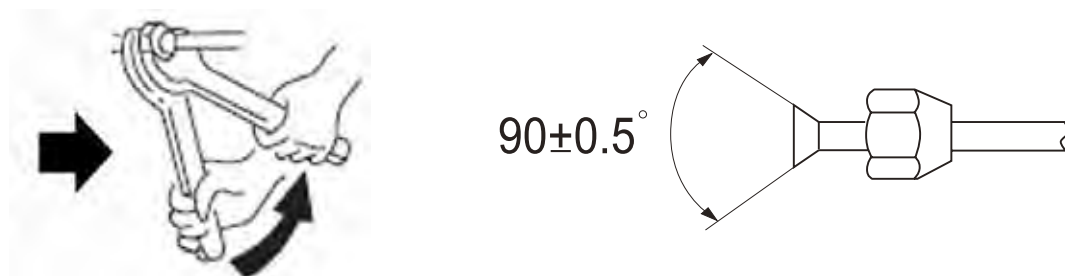

CONNECTION OF THE INDOOR UNIT REFRIGERATOR

Insulation of refrigerant connections

The area must be covered with insulation after the refrigerant pipes have been connected to the indoor unit.

If this insulation is missing, condensation will form in the pipe during summer operation. This causes drops of water to fall into the room.



Pressurisation

Once the refrigerant lines have been connected, the system is pressurised to eliminate any possible leaks and held at approximately 35 bars for a minimum of 60 minutes.

VACUUM PROCESS

This process consists of the extraction of ambient air from the refrigeration system and also the evaporation of residual internal moisture.

Moisture is very aggressive in its attack on both the coolant and the oil in the system.

In the event of contamination of the refrigeration circuit, replacement of the equipment will be necessary.

Advice / Recommendation: Circuit vacuum pressure 755 mm/Hg (0.0013 bar).

As the internal pressure in the refrigerant circuit decreases, so does the evaporation temperature of the water. This allows evaporation even at very low ambient temperatures.

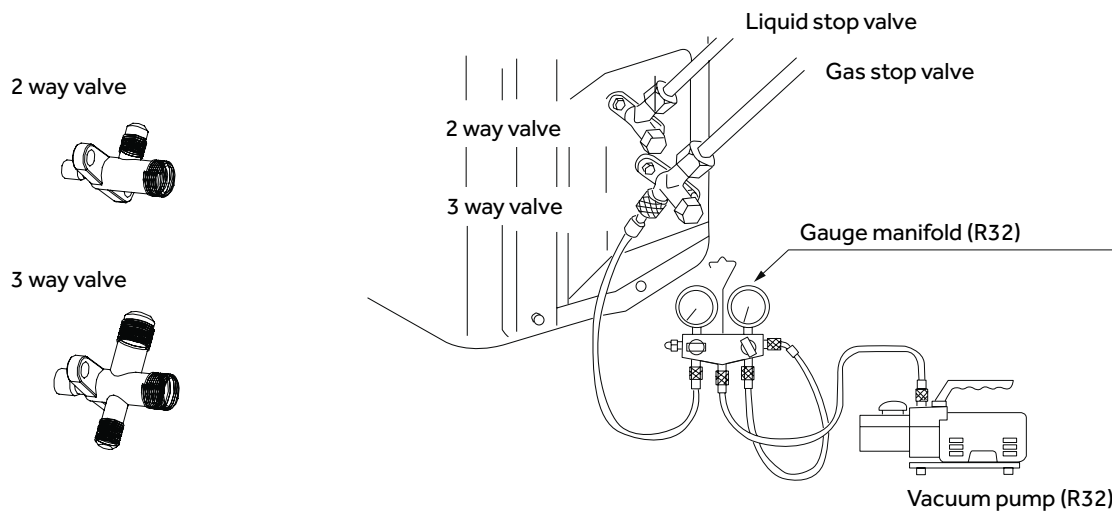

PRE-INSTALLATION DRAIN / DRAIN PRIOR TO INSTALLATION

1. Drain rigidity:
 - A. Rigid pipe: Check that there are no obstructions and that the level drops to the end (minimum 2%).
 - B. Flexible hose: Check for obstructions and correct excessive bends or sagging in its path. Excessive curvature in its path can obstruct the path of the water.
3. Siphons: Check that there are no problems with water drainage.
4. Water drain: Check with liquid flow that the drainage system is draining properly.

POWER SUPPLY

Power supply: this must always be single-phase, unless otherwise specified (equipment with three-phase power supply). It must never be two-phase.

NOMINAL DISTRIBUTION SYSTEM VOLTAGE		
Phase	/	1
Frequency	Hz	50
Voltage	V	230

A strong and reliable earthing is essential when installing.

ELECTRICAL PRE-INSTALLATION

Electrical installation inspection

- Wiring section in accordance with the power rating of the unit (may be in accordance with the installation manual).
- Check the junction boxes: check for possible connections and that the connection section is sufficient throughout the circuit up to the electrical panel.
- Check the condition of the insulation of the cable.

INTERCONNECT WIRING

- Type of electrical cable: Must be a protected electrical conduit, single-core wiring is not permitted for communication wiring. This is because the interconnect wiring is the conductive channel for communication between units, and the single wire is not designed or protected for this. The use of this type of cable can be a cause of communication failure, either during commissioning or during operation of the unit.
- Interconnection wiring section according to installation specifications, if applicable.

CONNECTED WALL PANEL

Wiring

In cases where the length of the remote-control cable is not sufficient, it is possible to extend it, but the number of wires and the type of cable must be taken into account.

Maximum wiring distance	Section and type
100 metres	3 x 0,5mm ² armoured / shielded

The connection between the power supply cable and the extension cable must be tin soldered. The use of more than one socket strip is not permitted.

MAINTENANCE WORK

Indoor unit		Recommended	Required
Air filter cleaning	Monthly	Yearly or at each change of season	If necessary, use water and a neutral detergent. Do not use degreasers or similar products as they may damage the mesh.
Cleaning of the batteries with bactericidal and fungicidal products.		Once a year or with every change of season	At the end of cleaning, rinse with plenty of water.
Reading of the flow / return temperature in cold mode		Once a year or with every change of season	The difference or temperature jump must be 11°C or more.
Reading of the flow / return temperature in heating mode		Once a year or with every change of season	The difference or temperature jump must be 11°C or more.
Check the condition of electrical connections and tighten electrical terminals		Once a year	If necessary, clean the connections or the wiring.

Indoor unit		
Use a clamp meter to measure power consumption.	Once a year	Compare with the nominal consumption on the nameplate or indoor unit.
Check that no external noise occurs.	Once a year	Fans, Turbines, Compressors, Casings.
Check that the thermostats and control elements are working properly.	Once a year	Replace the remote control batteries as required.
Check the water drain and the condensation water collection tray.	Once a year	
Inspection of the flared joints.		Fixing and insulating
Cleaning the fronts and aesthetics of the indoor unit.	Once a year	

Sample serial number: AABF46E0000X9N4B0770

The serial number always consists of 20 characters!

You can find the serial number: under the filter cover, on the installation manual that comes with the unit, and on the indoor unit packaging (box). For the outdoor unit, you can find the serial number in the label on the side, in the manual accompanying the unit, in the packaging (carton), and in the electrical compartment.

YEAR

A	B	C	D	E	F	G	H	J	K	L	M	N	P	Q	R	S	T
2010	2011	2012	2013	2014	2015	2016	2017	2018	2019	2020	2021	2022	2023	2024	2025	2026	2027

MONTH

1	2	3	4	5	6	7	8	9	A	B	C
January	February	March	April	May	June	July	August	September	October	November	December

DAY

1	2	3	4	5	6	7	8	9	A	B	C	D	E	F	G	H	J	K	L	M	N	P	Q	R	S	T	U	V	W	X
1	2	3	4	5	6	7	8	9	10	11	12	13	14	15	16	17	18	19	20	21	22	23	24	25	26	27	28	29	30	31

When a Haier unit is malfunctioning, you can locate the error message on both the indoor unit and the outdoor unit, from which you can tell the nature of the malfunction. Indoor units with display show the error code directly on the display.

INDOOR UNITS WITH ERROR CODE ON DISPLAY	
WALL-UNITS, 2 kW - 10 kW	
PEARL R290 AS25PBBHRA AS35PBBHRA	JADE SUPERMATCH AS25S2SJ1FA-3 AS35S2SJ1FA-3 AS50S2SJ1FA-3
EXPERT WHITE AS20XCAHRA AS25XCAHRA AS35XCAHRA AS50XCAHRA AS71XCAHRA	EXPERT BLACK AS20S2SF1FA-MB3 AS25S2SF1FA-MB3 AS35S2SF1FA-MB3 AS42S2SF1FA-MB3 AS50S2SF1FA-MB3 AS71S2SF1FA-MB3
FLEXIS PLUS BLACK AS25S2SF1FA-MB3 AS35S2SF1FA-MB3 AS50S2SF1FA-MB3 AS71S2SF1FA-MB3	FLEXIS PLUS WHITE AS20S2SF1FA-MW3 AS25S2SF1FA-MW3 AS35S2SF1FA-MW3 AS42S2SF1FA-MW3 AS50S2SF1FA-MW3 AS71S2SF1FA-MW3
PEARL PREMIUM AS20PBAHRA AS25PBPHRA-PRE AS35PBPHRA-PRE AS50PDPHRA-PRE AS71PEPHRA-PRE	REVIVE PLUS AS25RBAHRA-3 AS35RBAHRA-4 AS50RCBHRA-4 AS68RDAHRA-4
EXPERT NORDIC AS25XCHHRA-NR AS35XCHHRA-NR	PEARL NORDIC AS25PCHHRA-NR AS35PCHHRA-NR AS50PDHHRA-NR



For wall indoor units equipped with indicator LEDs, the error code can be detected based on the sequence of the LEDs (see Diagnostics page for error code - alarm description matching). Example: POWER LED= BLINKING; TIMER LED= OFF; OPERATION LED= OFF; AMBIENT PROBES FAILED. Below are the indoor units equipped with indicator LEDs. Consultar Angel F.

CONSOLE	
AF25S2SD1FA(D)	AF35S2SD1FA(D)
AF42S2SD1FA(D)	AF42S2SD1FA(H)
AF50S2SD1FA(D)	AF50S2SD1FA(H)
NB. In these units the error flashes, alternating the letter and error number.	



1 WAY CASSETTE	
AB25S2SA1FA(H)	AB35S2SA1FA(H)
AB50S2SA1FA(H)	AB71S2SA1FA(H)
CASSETTE 620	
AB25S2SC2FA(H)	AB35S2SC2FA(H)
AB50S2SC2FA(H)	AB71S2SG1FA(H)
NB. In these units the error flashes, alternating the letter and error number.	



ROUND FLOW CASSETTE	
ABH105H1ERG(H)	ABH125K1ERG(H)
ABH140K1ERG(H)	ABH160K1ERG(H)
NB. In these units the error flashes, alternating the letter and error number.	



CEILING FLOOR	
AC25S2SG1FA(H)	AC35S2SG1FA(H)
AC50S2SG1FA(H)	AC71S2SG1FA(H)
AC105S2SH1FA(H)	AC125S2SK1FA(H)
AC140S2SK1FA(H)	AC160S2SK1FA(H)
NB. In these units the error flashes, alternating the letter and error number.	



For ceiling-indoor units equipped with signal LEDs, the error code can be detected based on the amount of flashes of the TIMER and OPERATION LEDs. (See Diagnostics page for error code - alarm description matching).

Example: TIMER LED flashing 0 time; OPERATION LED flashing 1 time; ambient probe faulty.

SLIM DUCT LOW PRESSURE	
AD25S2SS1FA(H)	AD35S2SS1FA(H)
AD50S2SS1FA(H)	AD71S2SS1FA(H)
DUCTED MEDIUM PRESSURE	
AD35S2SM3FA(H)	AD50S2SM3FA(H)
AD71S2SM3FA(H)	AD105S2SM3FA(H)
AD105S2SM8FA(H)	AD125S2SM8FA(H)
AD140S2SM8FA(H)	AD160S2SM3FA(H)
DUCTED HIGH PRESSURE	
ADH125H1ERG	ADH140H1ERG
ADH160H1ERG	ADH200H1ERG
ADH250H1ERG	
NB. In these units the error flashes, alternating the letter and error number.	



ALL COMFORT TOWER
AP71UFAHRA-1
NB. In these units the error flashes, alternating the letter and error number.

TOWER
AP71DFMHRA
NB. In these units the error flashes, alternating the letter and error number.

CABINET	
AP105S2SK1FA(H)	AP140S2SK1FA(H)
AP140S2SK1FA(H)	AP160S2SK1FA(H)
NB. In these units the error flashes, alternating the letter and error number.	

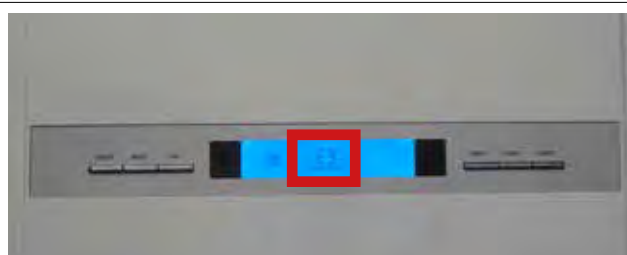

OUTDOOR UNITS WITH ERROR SIGNALING AMOUNT OF ERROR LED FLASHES	
MONOSPLIT UNITS, 2.5 kW - 10.5 kW	
AS10S2SF2FA-2	AS35S2SJ1FA-3
AS20PBAHRA	AS35S2SN1FA-NRC
AS20S2SF1FA-MB3	AS35XCAHRA
AS20S2SF1FA-MW3	AS35XCHHRA-NR
AS20XCAHRA	AS42S2SF1FA-MB3
AS25PBBHRA	AS42S2SF1FA-MW3
AS25PBPBPHRA-PRE	AS42XCAHRA-1
AS25PCHHRA-NR	AS50PDHHRA-NR
AS25RBAHRA-3	AS50PDPHRA-PRE
AS25S2SF1FA-MB3	AS50RCBHRA-4
AS25S2SF1FA-MW3	AS50S2SF1FA-MB3
AS25S2SJ1FA-3	AS50S2SF1FA-MW3
AS25S2SN1FA-NRC	AS50S2SF1FA-MW3
AS25XCAHRA	AS50S2SJ1FA-3
AS25XCHHRA-NR	AS50S2SN1FA-NRC
AS35PBBHRA	AS50XCAHRA
AS35PBPBPHRA-PRE	AS68RDAHRA-4
AS35PCHHRA-NR	AS71PEPHRA-PRE
AS35RBAHRA-4	AS71S2SF1FA-MB3
AS35S2SF1FA-MB3	AS71S2SF1FA-MW3
AS35S2SF1FA-MW3	AS71XCAHRA
AS35S2SF1FA-MW3	

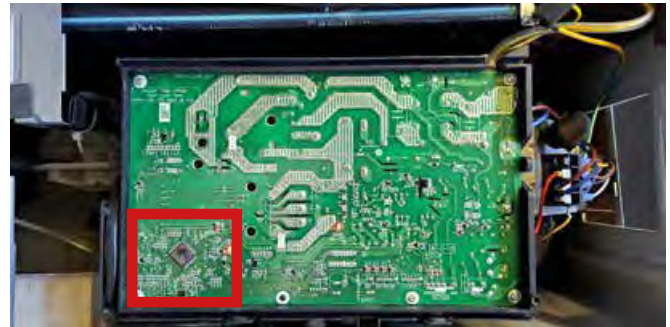

N.B. the position of the error LED may vary depending on the model of the unit.

OUTDOOR UNITS WITH ERROR SIGNALING AMOUNT OF ERROR LED FLASHES	
MULTISPLIT UNITS, 4 kW - 5.2 kW	
2U40S2SM1FA	2U50S2SM1FA-3



For outdoor units with a display, the error code can be detected directly on the display.
(see Diagnostics page for error code - alarm description matching).

N.B. the position of the DISPLAY may vary depending on the model of the unit.

OUTDOOR UNITS WITH ERROR SIGNALING ON DISPLAY	
MULTISPLIT UNITS, 5.5 kW - 12.5 kW	
3U55S2SR5FA	3U70S2SR5FA
4U75S2SR5FA	4U85S2SR5FA
5U90S2SS5FA	5U105S2SS5FA
5U125S2SN1FA	

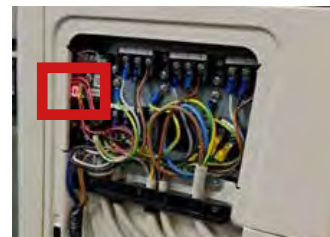

- At the time of reporting by the customer, try to obtain as much information as possible including: indoor/outdoor unit model and possible alarm reports.
- You can download technical reference material (diagnostics, electrical schemes, spare parts lists, etc.) by entering your credentials through the website **www.haierhvac.eu/en**.
- On your first visit, ask for the serial number of the unit.
- Try to understand if the LEDs on the indoor unit flash or light up in a particular sequence, or if alarm codes appear if the unit is equipped with a display.
- In units controlled by the wired controller, the alarms do not go out spontaneously but must be recalled according to the procedure described in your user manual.
(For example: To recall alarms with the YR-E17 wired touch-screen controller, press the TIME key for 10 seconds)

Check temperature probe alarms

- Verify with the tester that the probe is not interrupted or short-circuited. If so, replace it.
- Verify that the measured ohmic value is consistent with the temperature that the probe measures.
- Once you have identified the type of probe and measured its ohmic value, use the table on page XXXX to identify the type and characteristics of the probe.
- When replacing a probe, always verify (measuring it with the tester) that it is of correct type.

Check communication alarm between indoor and outdoor units (e.g. E7.)

- Try disconnecting the voltage for a couple of minutes, then try restarting the air conditioner. In some cases it may be a transient alarm caused by external disturbances.
 - For testing only, reverse the wire "1" with the wire "2" between the indoor and outdoor units in the terminal block. Due to different product versions, it is possible that the phase and neutral are reversed between the 2 units.
- Verify alarm signals on both indoor and outdoor units and check if there is a reference to a specific fault.
- Verify if the problem is caused by the indoor unit(s), outdoor units, or the wiring as indicated below:
 - Verify that in ventilation mode the indoor unit turns on and responds to all settings given by your controller. This will verify with a good probability that it is working.
 - Verify the wiring between the units, (continuity and polarity, shielding when required). If in doubt try using a "jumper" cable.
 - Before the alarm is signaled in the outdoor unit with a 4-wire terminal block (L,N,COM,TERRA), verify that there is an alternating (also variable) voltage between the neutral and communication terminal other than 0 V. If this is not the case, try replacing the indoor unit card.
 - In the inverter outdoor units, measure the continuous voltage at the heads of the condensers connected to the power module between P(-), N(-). It must correspond to a voltage of about 310 Vdc. If not, check with the tester that the inductance gives continuity, otherwise it is possible to temporarily bypass it by shorting the wires on the module/board. Verify that the power module is powered by 230 Vac in the respective terminals, and that the main board is powered.
 - If the communication alarm appears on the indoor unit but there are no alarms on the outdoor unit, proceed to verify:
 1. continuous voltage 310 Vdc P-N on the module where possible
 2. continuous voltage 310 Vdc fan motor
 3. impedances on DC fan motor wires
 If in doubt about faulty fan and main board without alarms, replace them both.

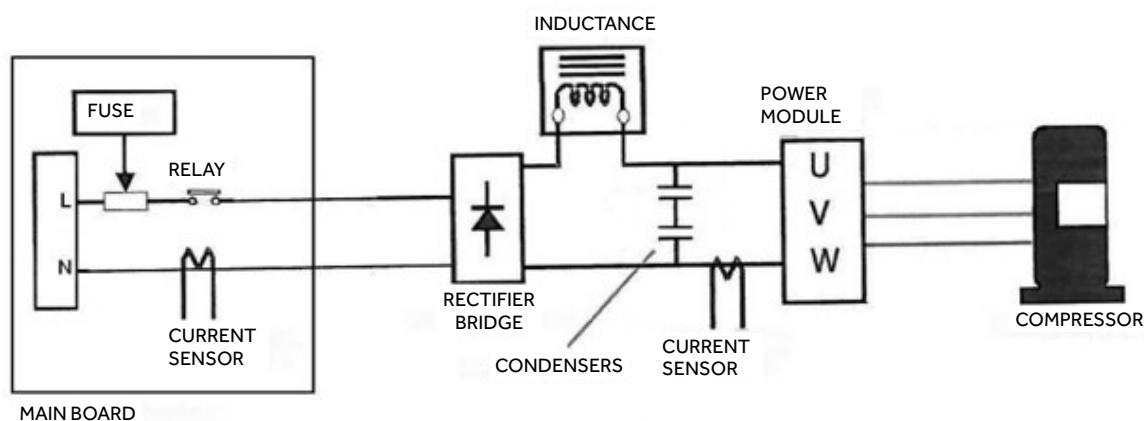

Electrical checks on the compressor

- Inverter / three-phase compressor: Measure the impedance of the phases by verifying that there are exactly equal values between the respective U,V,W or R,S,T terminals. Usually the value is about a few ohm. Disconnect all cables from the compressor before measuring.
- ON-OFF single-phase compressor: Measure the impedance of the run winding (C- R) and start winding (C-S) between the respective C,S,R terminals.

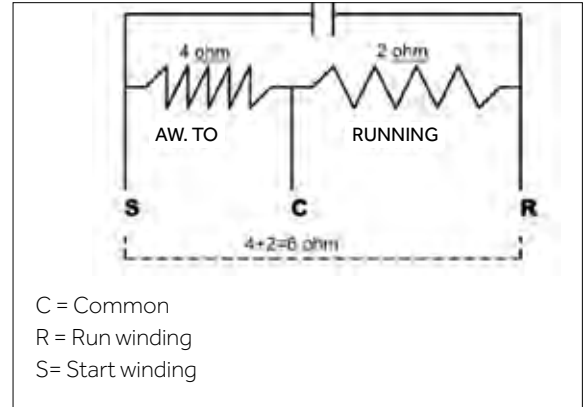

The sum of both windings must be equal to the impedance between R and S.

- Measuring the absorption directly in the phase of the outdoor terminal block, can make us understand if the consumption of the compressor falls into the rating plate data or not. In the On-Off compressors the start condenser can be the cause of excessive absorption. In inverter compressors, measuring the current on one of the three phases with the current clamp in c.a. can verify if there are abnormal absorptions. In fact, in the start phase, it has to rise slowly from the minimum consumption.
- Measure the impedance of each winding towards the ground verifying that it is not less than 20 Mohm. This would indicate that there is a possible leakage that could cause the circuit breaker to intervene.
- The above tests can only give us a first idea of the state of the compressor, but they are not enough to completely exclude a possible problem. For example, they do not detect mechanical blockages.

Fan Motor Verification (DC)

In case of alarm E14 (indoor) or F8 (outdoor) make some checks according to the following indications:

1. Check the connector connection.
2. Check that the motor output voltage is 315 Vdc (pin 1-4)
3. Check that the motor control voltage is 15 Vdc (pin 4-5).
4. Check the rotation command output voltage (pins 4-6).
5. Check rotation input pulses (pin 4-7).

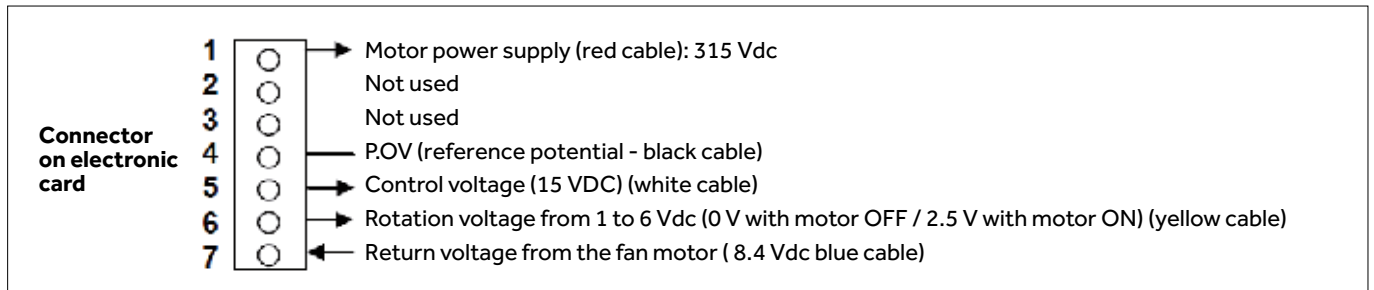

Resistive values of some fan motors

INDOOR UNIT MOTORS		
Motor Code 0010403317G		
OHM MEASUREMENTS	TYPICAL VALUE	FAULT VALUE
WHITE / BLACK	40kΩ	<100Ω
YELLOW / BLACK	226kΩ	<60kΩ
BLUE / BLACK	5.35MΩ	<100Ω
RED / BLACK	--	<1MΩ

INDOOR UNIT MOTORS		
Motor Code 0010403317G		
OHM MEASUREMENTS	TYPICAL VALUE	FAULT VALUE
WHITE / BLACK	40kΩ	<100Ω
YELLOW / BLACK	226kΩ	<60kΩ
BLUE / BLACK	5.35MΩ	<100Ω
RED / BLACK	--	<1MΩ

INDOOR UNIT MOTORS		
Motor Code 0150401250A		
OHM MEASUREMENTS	TYPICAL VALUE	FAULT VALUE
WHITE / BLACK	53kΩ	<100Ω
YELLOW / BLACK	170kΩ	<60kΩ
BLUE / BLACK	4.6MΩ	<1MΩ
RED / BLACK	1.3MΩ	<1MΩ

INDOOR UNIT MOTORS		
Motor Code 0150401253A		
OHM MEASUREMENTS	TYPICAL VALUE	FAULT VALUE
WHITE / BLACK	55kΩ	<100Ω
YELLOW / BLACK	171kΩ	<60kΩ
BLUE / BLACK	4.8MΩ	<1MΩ
RED / BLACK	1.3MΩ	<1MΩ

INDOOR UNIT MOTORS

Motor Code 0010403317U

OHM MEASUREMENTS	TYPICAL VALUE	FAULT VALUE
WHITE / BLACK	40kΩ	<100Ω
YELLOW / BLACK	210kΩ	<60kΩ
BLUE / BLACK	--	<100Ω
RED / BLACK	--	<1MΩ

INDOOR UNIT MOTORS

Motor Code 0010404101BL

OHM MEASUREMENTS	TYPICAL VALUE	FAULT VALUE
WHITE / BLACK	1,5MΩ	<100Ω
YELLOW / BLACK	167kΩ	<60kΩ
BLUE / BLACK	--	<1MΩ
RED / BLACK	--	<1MΩ

INDOOR UNIT MOTORS

Motor Code 0150400714

OHM MEASUREMENTS	TYPICAL VALUE	FAULT VALUE
WHITE / BLACK	1MΩ	<100Ω
YELLOW / BLACK	208kΩ	<60kΩ
BLUE / BLACK	5.2MΩ	<1MΩ
RED / BLACK	3.1MΩ	<1MΩ

INDOOR UNIT MOTORS

Motor Code 0010403322A

OHM MEASUREMENTS	TYPICAL VALUE	FAULT VALUE
WHITE / BLACK	49kΩ	<100Ω
YELLOW / BLACK	154kΩ	<60kΩ
BLUE / BLACK	--	<1MΩ
RED / BLACK	3.7MΩ	<1MΩ

INDOOR UNIT MOTORS

Motor Code 0010401254

OHM MEASUREMENTS	TYPICAL VALUE	FAULT VALUE
WHITE / BLACK	28kΩ	<100Ω
YELLOW / BLACK	247kΩ	<60kΩ
BLUE / BLACK	4.6MΩ	<1MΩ
RED / BLACK	4.7MΩ	<1MΩ

INDOOR UNIT MOTORS

Motor Code 0010400771

OHM MEASUREMENTS	TYPICAL VALUE	FAULT VALUE
WHITE / BLACK	53kΩ	<100Ω
YELLOW / BLACK	104kΩ	<60kΩ
BLUE / BLACK	63kΩ	<100Ω
RED / BLACK	4.7MΩ	<1MΩ

INDOOR UNIT MOTORS

Motor Code 0010404886

OHM MEASUREMENTS	TYPICAL VALUE	FAULT VALUE
WHITE / BLACK	40kΩ	<100Ω
YELLOW / BLACK	210kΩ	<60kΩ
BLUE / BLACK	--	<100Ω
RED / BLACK	--	<1MΩ

INDOOR UNIT MOTORS

Motor Code 0010401703

OHM MEASUREMENTS	TYPICAL VALUE	FAULT VALUE
WHITE / BLACK	5MΩ	<1MΩ
YELLOW / BLACK	195kΩ	<60kΩ
BLUE / BLACK	--	<1MΩ
RED / BLACK	--	<1MΩ

INDOOR UNIT MOTORS

Motor Code 0150401754A

OHM MEASUREMENTS	TYPICAL VALUE	FAULT VALUE
WHITE / BLACK	2.2MΩ	<100Ω
YELLOW / BLACK	216kΩ	<60kΩ
BLUE / BLACK	--	<1MΩ
RED / BLACK	3.3MΩ	<1MΩ

INDOOR UNIT MOTORS

Motor Code 0010401254B

OHM MEASUREMENTS	TYPICAL VALUE	FAULT VALUE
WHITE / BLACK	49kΩ	<100Ω
YELLOW / BLACK	154kΩ	<60kΩ
BLUE / BLACK	--	<1MΩ
RED / BLACK	3.7MΩ	<1MΩ

INDOOR UNIT MOTORS

Motor Code 0010401087

OHM MEASUREMENTS	TYPICAL VALUE	FAULT VALUE
WHITE / BLACK	53kΩ	<100Ω
YELLOW / BLACK	104kΩ	<60kΩ
BLUE / BLACK	63kΩ	<100Ω
RED / BLACK	1.3MΩ	<1MΩ

INDOOR UNIT MOTORS

Motor Code 0010401832

OHM MEASUREMENTS	TYPICAL VALUE	FAULT VALUE
WHITE / BLACK	53kΩ	<100Ω
YELLOW / BLACK	147kΩ	<60kΩ
BLUE / BLACK	--	<100Ω
RED / BLACK	4.7MΩ	<1MΩ

Power module verification:

In Haier boards, power modules can be integrated into the motherboard or external to the motherboard.

Power module front external to the motherboard

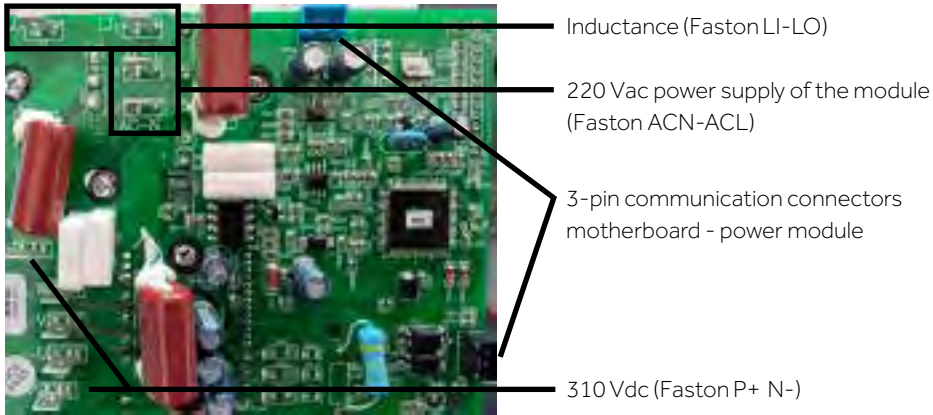

Power module back external to the motherboard

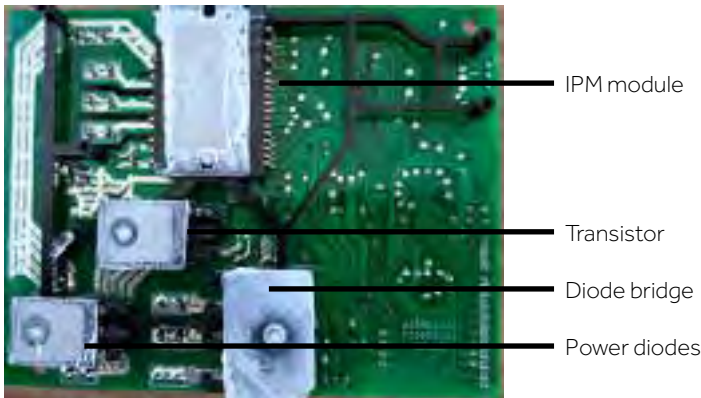

Power module back integrated to the motherboard

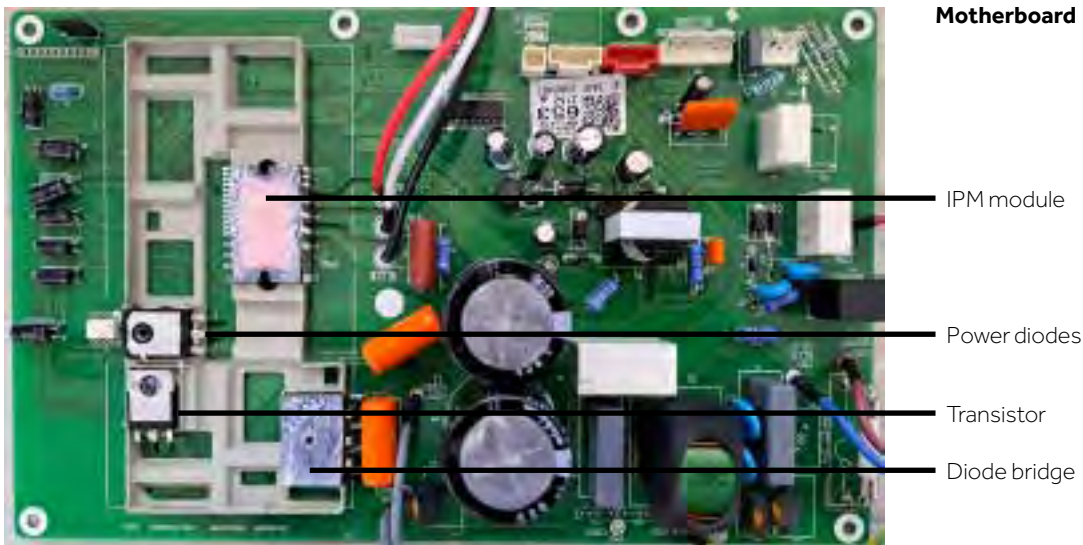

The location of components may change depending on the model of the unit.

Power module verification:

In the event of a fault, follow these steps to check the power module:

1. For units with separate power modules, you can check:

- The connection of the 3-pin communication connectors between the motherboard and the power module.
- With a multimeter, check the continuity of the communication cables just mentioned.
- Also, check the voltages of 5 Vdc and 15 Vdc at the blue communication connector with cable connected. If the voltages are not present, repeat the measurement directly on the cable connector with the cable disconnected to see if the module is shorted or if the motherboard is not supplying power to the module.
- Check the voltage between the P+ and N- fastons of the power module (with cables connected); this value should be about 310 Vdc.
- If 310 VDC voltage is not present, check the continuity of the inductance.
- If the inductance is in continuity, check the voltage between the ACL and ACN fastons of the power module (with cables connected). If this value is not about 220 Vac, check the power supply to the motherboard. If the power supply is about 220 Vac replace the motherboard.

Detail of the communication connector on the external power modules



Between 1-2 = 5 Vdc
Between 3-2 = 15 Vdc

2. For power modules integrated to the motherboard, you can check:

- 310 Vdc voltage directly to the fan motor connector.
- If this is not present, check that the inductance is in continuity.
- If the inductance is in continuity, check the power supply to the motherboard.
- If the power supply is about 220 Vac replace the motherboard.

It is also possible to check the integrity of the components most subject to stress, such as the diode bridge, power diodes, transistor and integrated IPM.

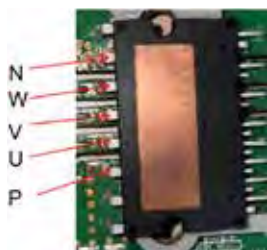

Integrated IPM:

The impedance of the integrated IPM can be measured (with the compressor disconnected), precisely between:

P and U,V,W.

The verification should be repeated by measuring the resistance between N and U,V,W.

If the measurements all fall between the 1MΩ and 10MΩ values, there is a good chance that the component is functional.

If, on the contrary, the measurements are not within the above values, the component is faulty.

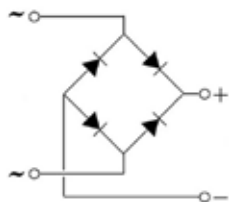

Diode bridge

By setting the tester to diode verification mode, it is possible to verify that all diodes within the diode bridge are intact.



Power diodes

By setting the tester to diode verification mode, it is possible to verify that the two diodes inside the component are intact.

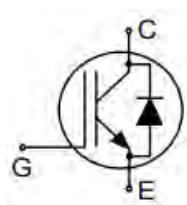

Transistor

By setting the tester to diode verification mode, it is possible to verify that the diode inside the component located between pins "E" and "C" is intact.

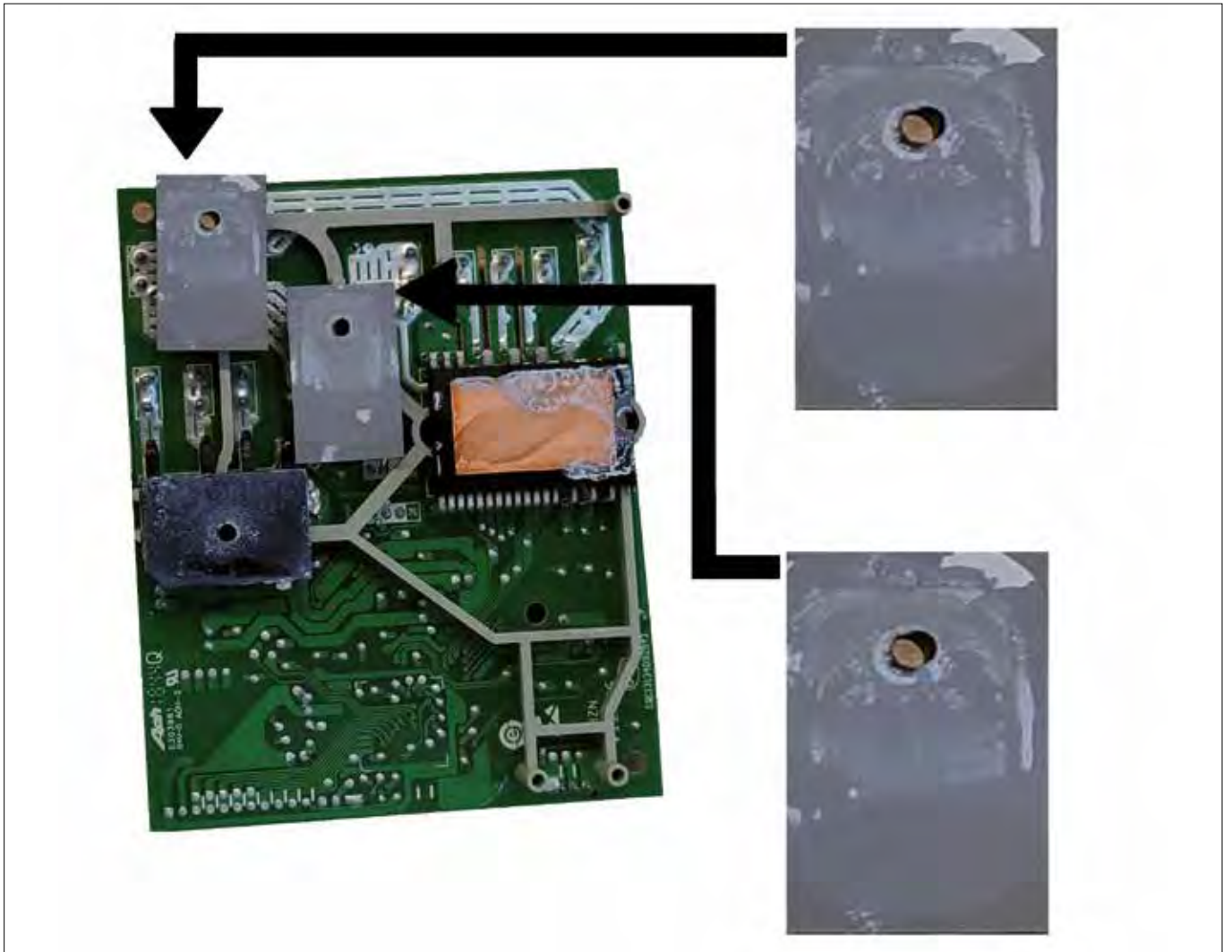

The figure opposite shows the insulating sheets placed under the TRIACs.

During any module replacement, make sure that these insulators do not remain attached to the old power module

- A pressure different than normal functioning can be a symptom of bad thermal exchange, crushed piping, incorrect refrigerant charge.
- Always ensure that the lengths and elevations are within the limits provided by the constructor.
- In the case of pipes exceeding the standard, make an additional charge of refrigerant according to the quantities listed in the catalog/ installation manual.
- To exclude that the gas is polluted with nitrogen as a result of pressurizing the system, check when the unit is stopped that the gas pressure corresponds to the table at the back of this manual and that there is a relationship between gas pressure and temperature.

The above measures may vary depending on the conditions of use, so these citations remain purely indicative and should be interpreted taking into account the other tests mentioned in this manual depending on the models in question.

Some of the phenomena below are usually accompanied by poor yield of the device.

Frequent issues during cooling operation:

The outdoor unit refrigerant line is prone to frost

The main causes are as follows:

- Lack of refrigerant
- Dirty filters
- Faulty indoor unit fan
- Poor circulation of refrigerant (e.g. crushed pipes, capillary obstruction)

Dynamic pressure is relatively low compared to normal operation

- Refrigerant may be missing. Check for leaks and restore the system with the correct charge.
- The indoor unit may not have a proper thermal exchange, (filters, fan, exchanger, obstacles)
- Poor circulation of refrigerant (e.g. crushed pipes, capillary obstruction).

Dynamic pressure is relatively high compared to normal operation

- There may be too much gas due to an incorrect refill.
- The outdoor unit may not have a proper thermal exchange.

The indoor unit gives off bad smells

- It is important to check that the discharge has the right slope, and it must also be verified that it has not been directly connected to the sewerage system.
- Check the cleaning of the exchanger and filters of the indoor unit.

Frequent issues during heat pump operation:

The outdoor unit is covered with ice

- Verify that the air conditioner has been sized correctly with respect to the place.
- Verify that the indoor unit does not work at ambient temperature below 16°C and there are no obstacles that can affect the thermal exchange of exchangers.
- Turning the air conditioner on and off frequently can reset the defrosting cycles and facilitate icing in the outdoor unit.
- Verify that the refrigerant charge matches the indicated rating plate data considering any additions for lengths longer than the standard.

Dynamic pressure is relatively low compared to normal operation

- Refrigerant may be missing. Check for leaks and restore the system with the correct charge.
- The outdoor unit may not have a proper thermal exchange.
- Operating temperatures (indoor/outdoor) are too low.

Dynamic pressure is relatively high compared to normal operation

- The indoor unit may not have a proper thermal exchange, (filters, fan, exchanger, obstacles).
- There may be too much gas due to an incorrect refill.
- Obstruction to the capillary, crushed pipes
- Operating temperatures (indoor/outdoor) are too high.

MODEL YR-HE



EXTRA
FUNCTION
CONFIRM

HEALTH

LIGHT

Selecting the ambient temperature/set-point on the display: (excluding Round flow cassettes / FA-ZUN Tower)	Key
To switch the display between real temperature and environment set-point, press the LIGHT key of the remote control 10 times; the indoor unit will respond with: 2 BEEP sounds to display ambient temperature, 4 BEEP sounds to display set-point temperature.	LIGHT
Selecting the automatic restart at power failure:	Key
Press "EXTRA FUNCTION" key until "SLEEP" (wake up) icon appears and then press "CONFIRM" key 10 times to select/deselect automatic restart after power failure. The indoor unit will respond with 2 BEEPs for disabled function (not restarts) and 4 BEEPs for enabled function (restarts after power failure with last settings).	EXTRA F. + CONFIRM
Activating/deactivating power-saving feature of the fan motor in cooling mode:	Key
Directing the remote control to the indoor unit: 1. Press the "AUTO" (or "SMART") key. 2. Press the "HEALTH" key 6 times. The indoor unit will respond with 2 "BEEP" sounds and the eco function will be disabled. The fan will always be in operation, even if the set ambient temperature is reached. By repeating steps 1 and 2, the indoor unit will respond with 4 "BEEP" sounds and the eco function will be reactivated. The fan will be stopped when the set ambient temperature is reached.	AUTO or SMART / HEALTH
Activating the ventilation mode:	Key
You can set the ventilation function by using the "EXTRA FUNCTION" key until the "FAN" icon is selected and then pressing "CONFIRM."	EXTRA F.

COMPATIBILITY YR-HE

PEARL R290

MODEL YR-HE2



HEALTH

EXTRA
FUNCTION
CONFIRM

LIGHT

Selecting the ambient temperature/set-point on the display: (excluding Round flow cassettes / FA-ZUN Tower)	Key
To switch the display between real temperature and environment set-point, press the LIGHT key of the remote control 10 times; the indoor unit will respond with: 2 BEEP sounds to display ambient temperature, 4 BEEP sounds to display set-point temperature.	LIGHT
Selecting the automatic restart at power failure:	Key
Press "EXTRA FUNCTION" key until "SLEEP" (wake up) icon appears and then press "CONFIRM" key 10 times to select/deselect automatic restart after power failure. The indoor unit will respond with 2 BEEPs for disabled function (not restarts) and 4 BEEPs for enabled function (restarts after power failure with last settings).	EXTRA F. + CONFIRM
Activating/deactivating power-saving feature of the fan motor in cooling mode:	Key
Directing the remote control to the indoor unit: 1. Press the "AUTO" (or "SMART") key. 2. Press the "HEALTH" key 6 times. The indoor unit will respond with 2 "BEEP" sounds and the eco function will be disabled. The fan will always be in operation, even if the set ambient temperature is reached. By repeating steps 1 and 2, the indoor unit will respond with 4 "BEEP" sounds and the eco function will be reactivated. The fan will be stopped when the set ambient temperature is reached.	AUTO or SMART / HEALTH
Activating the ventilation mode:	Key
You can set the ventilation function by using the "EXTRA FUNCTION" key until the "FAN" icon is selected and then pressing "CONFIRM."	EXTRA F.

COMPATIBILITY YR-HE2

PEARL PREMIUM

REVIVE PLUS

PEARLNORDIC

MODEL YR-HRS01	
Selecting the room temperature/set-point on the display: (except Round flow cassette / FA-ZUN tower)	Key
To switch the display between real temperature and environment set-point, press the LIGHT key of the remote control 10 times; the indoor unit will respond with: 2 BEEP sounds to display ambient temperature, 4 BEEP sounds to display set-point temperature.	LIGHT
Selecting the automatic restart at power failure:	Key
Press the "SLEEP" key 10 times to select/deselect automatic restart after power failure. The indoor unit will respond with 2 BEEPs for disabled function (not restarts) and 4 BEEPs for enabled function (restarts after power failure with last settings).	SLEEP
Activating/deactivating power-saving feature of the fan motor in cooling mode:	Key
Directing the remote control to the indoor unit: 1. Press the "AUTO" (or "SMART") key. 2. Press the "HEALTH" key 6 times. The indoor unit will respond with 2 "BEEP" sounds and the eco function will be disabled. The fan will always be in operation, even if the set ambient temperature is reached. By repeating steps 1 and 2, the indoor unit will respond with 4 "BEEP" sounds and the eco function will be reactivated. The fan will be stopped when the set ambient temperature is reached.	AUTO or SMART / HEALTH
Selecting the automatic restart at power failure:	Key
Press 10 times the "SLEEP" key on the remote control; the indoor unit will respond with 2 BEEPs for disabled function (not restarts) and with 4 BEEPs for enabled function (restarts after power failure with last settings).	SLEEP
Temperature compensation: +/- 4°C on commercial units	Key
THEN FOLLOW THE NOTES BELOW: 1. Turn on the unit using the remote control. 2. From remote control, select the HEAT PUMP mode at 24°C. 3. Press the "SLEEP" button 7 times in 5 seconds. The indoor unit must issue 2 confirmation "BEEP" sounds. If you do not hear any sound repeat step 3. 4. Turn off the unit via the remote control and you will hear 4 "BEEP" sounds for confirmation 5. Remove voltage and then restart the system. N.B.: If you want to set a different compensation temperature, set a higher or lower temperature in step 2 instead of setting 24 °C. Considering the starting 24 °C as point 0, each additional degree will give a positive compensation (e.g. 25 °C = +1 °C, 26 °C = +2 °C) instead, every less degree will give a negative compensation (e.g. 23 °C = -1 °C, 22 °C = -2 °C). Make sure that no offsets have already been set up using the wired controller Doing so requires that you have: - A receiver card (e.g. receiver in the cassette unit panel, or REO2 receiver interface) - A remote control with the "SLEEP" button.	SLEEP
Setting Celsius/Fahrenheit degrees	Key
By repeatedly pressing the "MENU" key until the temperature unit flashes, you can change the display from degrees Fahrenheit to Celsius and vice versa. It should be done with the remote control turned on in cooling/heat pump mode. Once the change is made, it must be confirmed with the "OK" key.	MENU / OK

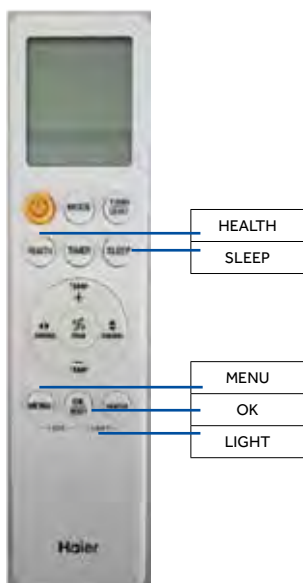

COMPATIBILITY YR-HRS01						
CONSOLE	SLIM DUCTED LOW P.	DUCTED MEDIUM P.	DUCTED HIGH P.	1-WAY CASSETTE	CASSETTE 620	CABINET

MODEL YR-HQS01	
Selecting the room temperature/set-point on the display: (except Round flow cassette / FA-ZUN tower)	Key
To switch the display between real temperature and environment set-point, press the LIGHT key of the remote control 10 times; the indoor unit will respond with: 2 BEEP sounds to display ambient temperature, 4 BEEP sounds to display set-point temperature.	LIGHT
Selecting the automatic restart at power failure:	Key
Press the "SLEEP" key 10 times to select/deselect automatic restart after power failure. The indoor unit will respond with 2 BEEPs for disabled function (not restarts) and 4 BEEPs for enabled function (restarts after power failure with last settings).	SLEEP
Activating/deactivating power-saving feature of the fan motor in cooling mode:	Key
Directing the remote control to the indoor unit: 1. Press the "AUTO" (or "SMART") key. 2. Press the "HEALTH" key 6 times. The indoor unit will respond with 2 "BEEP" sounds and the eco function will be disabled. The fan will always be in operation, even if the set ambient temperature is reached. By repeating steps 1 and 2, the indoor unit will respond with 4 "BEEP" sounds and the eco function will be reactivated. The fan will be stopped when the set ambient temperature is reached.	AUTO or SMART / HEALTH
Selecting the automatic restart at power failure:	Key
Press 10 times the "SLEEP" key on the remote control; the indoor unit will respond with 2 BEEPs for disabled function (not restarts) and with 4 BEEPs for enabled function (restarts after power failure with last settings).	SLEEP
Temperature compensation: +/- 4°C on commercial units	Key
THEN FOLLOW THE NOTES BELOW: 1. Turn on the unit using the remote control. 2. From remote control, select the HEAT PUMP mode at 24°C. 3. Press the "SLEEP" button 7 times in 5 seconds. The indoor unit must issue 2 confirmation "BEEP" sounds. If you do not hear any sound repeat step 3. 4. Turn off the unit via the remote control and you will hear 4 "BEEP" sounds for confirmation 5. Remove voltage and then restart the system. N.B.: If you want to set a different compensation temperature, set a higher or lower temperature in step 2 instead of setting 24 °C. Considering the starting 24 °C as point 0, each additional degree will give a positive compensation (e.g. 25 °C = +1 °C, 26 °C = +2 °C) instead, every less degree will give a negative compensation (e.g. 23 °C = -1 °C, 22 °C = -2 °C). Make sure that no offsets have already been set up using the wired controller Doing so requires that you have: - A receiver card (e.g. receiver in the cassette unit panel, or RE02 receiver interface) - A remote control with the "SLEEP" button.	SLEEP
Setting Celsius/Fahrenheit degrees	Key
By repeatedly pressing the "MENU" key until the temperature unit flashes, you can change the display from degrees Fahrenheit to Celsius and vice versa. It should be done with the remote control turned on in cooling/heat pump mode. Once the change is made, it must be confirmed with the "OK" key.	MENU / OK



COMPATIBILITY YR-HQS01							
CONSOLE	1 WAY CASSETTE	CASSETTE 620	CASSETTE ROUND FLOW	CEILING FLOOR	SLIM DUCT LOW PRESSURE	DUCTED MEDIUM PRESSURE	DUCTED HIGH PRESSURE



SLEEP
HEALTH
LIGHT
APPLY F/C

MODEL YR-HQ	
Setting Celsius/Fahrenheit degrees	Key
Use the dedicated F/C key with the remote control switched on in cooling/heat pump mode to change the display from Fahrenheit to Celsius and vice versa.	F/C
Selecting the ambient temperature/set-point on the display: (excluding Round flow cassettes / FA-ZUN Tower)	Key
To switch the display between real temperature and environment set-point, press the LIGHT key of the remote control 10 times; the indoor unit will respond with: 2 BEEP sounds to display ambient temperature, 4 BEEP sounds to display set-point temperature.	LIGHT
Selecting the automatic restart at power failure:	Key
Press 10 times the "SLEEP" key on the remote control; the indoor unit will respond with 2 BEEPs for disabled function (not restarts) and with 4 BEEPs for enabled function (restarts after power failure with last settings).	SLEEP
Activating/deactivating power-saving feature of the fan motor in cooling mode:	Key
Directing the remote control to the indoor unit: 1. Press the "AUTO" (or "SMART") key. 2. Press the "HEALTH" key 6 times. The indoor unit will respond with 2 "BEEP" sounds and the eco function will be disabled. The fan will always be in operation, even if the set ambient temperature is reached. By repeating steps 1 and 2, the indoor unit will respond with 4 "BEEP" sounds and the eco function will be reactivated. The fan will be stopped when the set ambient temperature is reached.	AUTO or SMART / HEALTH
Activating the ventilation mode:	Key
You can activate the function by pressing the "HEALTH" key with the remote control off.	HEALTH

COMPATIBILITY YR-HQ	
ALL COMFORT TOWER	TOWER



SLEEP
HEALTH
EXTRA FUNCTION CONFIRM
LIGHT

MODEL YR-HJ	
Setting Celsius/Fahrenheit degrees	Key
By repeatedly pressing the "EXTRA FUNCTION" button until the temperature unit flashes, you can change the display from degrees Fahrenheit to Celsius and vice versa. It should be done with the remote control turned on in cooling/heat pump mode. Once the change is made, it must be confirmed with the "CONFIRM" key.	EXTRA F. / CONFIRM
Selecting the ambient temperature/set-point on the display: (excluding Round flow cassettes / FA-ZUN Tower)	Key
To switch the display between real temperature and environment set-point, press the LIGHT key of the remote control 10 times; the indoor unit will respond with: 2 BEEP sounds to display ambient temperature, 4 BEEP sounds to display set-point temperature.	LIGHT
Selecting the automatic restart at power failure:	Key
Press 10 times the "SLEEP" key on the remote control; the indoor unit will respond with 2 BEEPs for disabled function (not restarts) and with 4 BEEPs for enabled function (restarts after power failure with last settings).	SLEEP
Activating/deactivating power-saving feature of the fan motor in cooling mode:	Key
Directing the remote control to the indoor unit: 1. Press the "MODE" key until the "AUTO" mode is selected. 2. Press the "HEALTH" key 6 times. The indoor unit will respond with 2 "BEEP" sounds and the eco function will be disabled. The fan will always be in operation, even if the set ambient temperature is reached. By repeating steps 1 and 2, the indoor unit will respond with 4 "BEEP" sounds and the eco function will be reactivated. The fan will be stopped when the set ambient temperature is reached.	AUTO or SMART / HEALTH

COMPATIBILITY YR-HJ													
EXPERT	FLEXIS PLUS	PEARL	WALL 10 kW	CONSOLE	CAS. 620	CAS. ROUND FLOW	CEILING/FLOOR CONVERTIBLE	SLIM DUCTED LOW P.	DUCTED MEDIUM P.	DUCTED HIGH P.	TOW. (FA)	TOW. (ZUN)	CABINET
				•	•	•	•	•	•	•			•

Function test mode:

Forced cooling: using the "test" button located in the split units (usually located near the terminal) you can "force" the unit in cooling mode for 30min, thus excluding the reading of the probes.

Do the following:

- With the machine off, press and hold the "test" key until the buzzer emits 2 consecutive "BEEPs".
- Release the key.

This will start the unit in forced cooling mode. To exit this mode simply turn off the unit from the remote control or press the appropriate "test" key for 1 time.

Verification of operation

In order to determine the proper operation of an air conditioner in addition to the pressure of the refrigerant, the electrical absorption of the outdoor unit and the yield of the indoor unit ('t air intake - man.') must be considered (in an average cooling between 10 - 15°C of Δt , in heat pump on average between 20 - 30°C of Δt). There is also no precise operating pressure. It varies depending on the temperatures we have inside, outside and the type of refrigerant used.

- When operating in cooling mode under normal conditions of use, the difference between the temperature read with the thermometer in the OU gas tap* and the temperature read by the gauge (gas side) should be between 5-8°C (overheating reading).
*** To obtain a more precise measurement, measure directly in the compressor intake pipe.**
- When operating in heating mode under normal conditions of use, the difference between the temperature read by gauge (liquid side) and the temperature read with the thermometer in the OU liquid tap* should be between 3-5°C (supercooling reading).
*** To obtain a more precise measurement, measure directly before the laminating member.**
- If the dynamic pressure is similar to static pressure it can indicate a leakage problem of the 4-way valve or a problem with the compressor. Usually the absorption of the compressor shows very low values.

Alarm on outdoor unit display / led	Description of the alarm	Description / Cause	Indoor units: ducted cassette ceiling/floor conv. console		Indoor unit panel display: ceiling/floor conv. console wall	Display ducted cassette	Alarm on wired controller YR-E17A HW-SA201ABK HW-BA116ABK HW-BA101ABT	Alarm on wired controller YR-E16B HW-PA201ABK	Failure on indoor/outdoor unit
			Timer (yellow)	Operate / Run (green)					
	Indoor unit ambient temperature probe faulty	Faulty sensor or short-circuit for more than 2 consecutive minutes.	0	1	E1	01	01	1	Indoor Unit
	Indoor unit exchanger temperature probe faulty.	Faulty sensor or short-circuit for more than 2 consecutive minutes.	0	2	E2	02	02	2	
	Faulty EEPROM on the indoor unit board	EEPROM faulty indoor unit board	0	4	E4	04	04	4	
	Indoor unit ice protection	Indoor unit exchanger temperature too low	0	16	E5	10	10	16	
	Communication error between indoor and outdoor units	Lack of communication for more than 4 consecutive minutes	0	7	E7	07	07	7	
	Communication error between wired controller and indoor unit	Lack of communication for more than 4 consecutive minutes	0	8	E8	08 (07 flashing light on ducted version)	08	8	
	Condensed drainage system anomaly	Open floating contact for more than 25 minutes continuously/problem in wiring between board and float	0	12	E10	0C	0C	12	
	Power supply voltage anomaly	Voltage missing, voltage out-of-limits or indoor board faulty	0	13	E3 / C1	0D	0D	13	
	Indoor unit DC fan motor faulty**	DC motor wiring interrupted, motor failure, electronic board damaged	0	14	E14	0E	0E	14	
	DC voltage too high or too low	DC voltage of DC motor inverter module too high or low	0	17			11		
	Outdoor unit generic alarm	Check outdoor unit for alarms				E20	E20		Outdoor Unit
1	Malfunctioning of the EEPROM of the outdoor unit	EEPROM outdoor unit motherboard faulty	2	1	F01	15	15	21	
2	IPM hardware (power module) overcurrent	The alarm goes out 3 times in an hour and locks the machine.	2	2	F02	16	16	22	
3	Compressor overcurrent during deceleration	Overcurrent / faulty current control / phase sequence reversed (models ON OFF)	2	3	F03	17	17	23	
4	Abnormal communication between the control board and the compressor power module	Communication failure for more than 4 minutes between motherboard and SPDU/ISPM power module	2	4	F04	18	18	24	
5	Compressor overcurrent detected by control board	The alarm goes out 3 times in an hour and locks the machine.	2	5	F05	19	19	25	
6	High DC voltage or AC voltage	Voltage above 270 V or less than 187 V	2	6	F06	1A	1A	26	
7	Compressor current sampling circuit failure	The alarm goes out 3 times in an hour and locks the machine.	2	7	F07	1B	1B	27	
8	Compressor discharge temperature protection too high	Delivery temperature above 120°. The alarm goes out 3 times in an hour and locks the machine.	2	8	F08	1C	1C	28	
9	DC fan motor failure	The alarm goes out 3 times in an hour and locks the machine.	2	9	F09	1D	1D	29	
10	Outdoor unit defrosting temperature probe faulty (Te)	Temperature probe in short circuit or open circuit within last 60 seconds	3	0	F10	1E	1E	30	
11	Compressor intake temperature probe faulty (Ts)	Temperature probe in short circuit or open circuit within last 60 seconds	3	1	F11	1F	1F	31	
12	Outdoor unit ambient temperature probe faulty (Ta)	Temperature probe in short circuit or open circuit within last 60 seconds	3	2	F12	20	20	32	
13	Compressor delivery temperature probe faulty (Td)	Temperature probe in short circuit or open circuit within last 60 seconds	3	3	F13	21	21	33	
14	PFC circuit voltage too high	DC voltage too high on the inverter module	3	4	F14	22	22	34	
15	Communication error between indoor and outdoor units	Lack of communication for more than 4 consecutive minutes	3	5	F15	23	23	35	
16	Lack of refrigerant / clogging of refrigerant delivery tube	It reports an error and stops if it detects Td-Tci>=25°C for 1 minute after the compressor starts in cooling operating mode for 10 min. The alarm goes out after 3 times in an hour and locks the machine.	3	6	F16	24	24	36	
17	4-way valve switching failure	4-way valve coil damaged, disconnected or unpowered. Mechanical failure of the 4-way valve.	3	7	F17	25	25	37	

Continuing →

Alarm on outdoor unit display / led	Description of the alarm	Description / Cause	Indoor units: ducted cassette ceiling/floor conv. console		Indoor unit panel display: ceiling/floor conv. console wall	Display ducted cassette	Alarm on wired controller YR-E17A HW-SA201ABK HW-BA116ABK HW-BA101ABT	Alarm on wired controller YR-E16B HW-PA201ABK	Failure on indoor/outdoor unit
			Timer (yellow)	Operate / run (green)					
18	Loss of compressor synchronism detection	Inverter / compressor circuit failure	3	8	F18	26	26	38	Outdoor Unit
19	DC voltage or AC voltage low / PWM selection circuit error in the power module.	The alarm goes out 3 times in an hour and locks the machine.	3	9	F19	27	27	39	
20	Temperature protection of indoor unit piping too high	Check heat exchange / refrigerant charge / sensors / electronic board	4	0	F20	28	28	40	
21	Temperature protection of indoor unit piping too low	Check heat exchange / refrigerant charge / sensors / electronic board	4	1	F21	29	29	41	
22	PFC circuit overcurrent	DC overcurrent at the power module	4	2	F22	2A	2A	42	
23	Temperature too high for the power module	SPDU/ISPM module temperature too high. The alarm goes out 3 times in an hour and locks the machine.	4	3	F23	2B	2B	43	
24	Failed to start compressor / Overcurrent	The alarm goes out 3 times in an hour and locks the machine.	4	4	F24	2C	2C	44	
25	U-V-W compressor phase overcurrent / Module input overcurrent	Unbalanced phases, damaged windings on the compressor, power module	4	5	F25	2D	2D	45	
26	Lack of a phase in the power module	System reset / compressor phase check / power module failure	4	6	F26	2E	2E	46	
27	Input current verification circuit failure	Detached compressor cables / faulty amperometric control	4	7	F27	2F	2F	47	
28	No charge/faulty amperometric control	Check compressor - power module wiring	4	8	F28	30	30	48	
37	Compressor overcurrent detected by power module	Verify voltage to power module - faulty module	5	7	F37	39	39	57	
38	Power module temperature sensor failure	Sensor disconnected, broken, or poorly positioned / power module failure	5	8	F38	3A	3A	58	
39	Heat exchanger temperature sensor (TC) failure	Sensor disconnected, broken, or poorly positioned	5	9	F39	3B	3B	59	
42	High pressure switch alarm	High pressure switch unplugged/faulty/excessive refrigerant	6	2	F42	3E	3E	62	
43	Low pressure switch alarm	Low pressure switch unplugged/faulty/lack of refrigerant	6	3	F43	3F	3F	63	
44	Temperature protection of outdoor heat exchanger TC too high	Operating temperature too high, heat exchange problems, excessive refrigerant	6	4	F44	40	40	64	
45	Low system pressure protection	Operating temperature too low, heat exchange problems, low refrigerant	6	5	F45	41	41	65	

ATTENTION:

It is possible that on some outdoor unit boards, error codes are indicated with 2 LEDs (LED1 and LED2).

In this case, the reading of the flashes should be done as indicated below:

Mx10+N, where **M** is the number of flashes of LED1 and **N** is the number of flashes of LED2

Example: LED1 1 flash; LED2 7 flashes = 17 flashes (1x10+7).

Below are some models that are equipped with boards with this error-reading logic: 1U90S2SS2FA 1U105S2SS1FA 1U105S2SS2FA

Alarm on outdoor unit display / led	Description of the alarm	Description / Cause	Indoor units: ducted cassette ceiling/floor conv. console		Indoor unit panel display: ceiling/floor conv. console	Display ducted cassette	Wall-mounted unit				Alarm on wired controller YR-E17A HW-SA201ABK HW-BA116ABK HW-BA101ABT	Alarm on wired controller YR-E16B HW-PA201ABK	Failure on indoor/outdoor unit
			Timer (yellow)	Operate / run (green)			Display	Power	Timer	Operate			
	Indoor unit ambient temperature probe faulty.	Faulty sensor or short-circuit for more than 2 consecutive minutes.	0	1	E1	01	E1	L	S	S	01	1	Indoor Unit
	Indoor unit exchanger temperature probe faulty.	Faulty sensor or short-circuit for more than 2 consecutive minutes.	0	2	E2	02	E2	L	A	A	02	2	
	Power supply voltage anomaly	Voltage missing, voltage out-of-limits or indoor board faulty	0	13	E3 / C1	0D					0D	13	
	EEPROM faulty indoor unit board	EEPROM faulty indoor unit board	0	4	E4	04	E4	L	A	L	04	4	
	Communication error between wired controller and indoor unit	Lack of communication for more than 4 consecutive minutes	0	8	E8	08	E8				07 lamp	8	
	Indoor unit DC fan motor faulty**	DC motor wiring interrupted, motor failure, electronic board damaged	0	14	E14	0E	E14	S	A	L	0E	14	
	Outdoor unit generic alarm	Check outdoor unit for alarms				E20	E20	S	L	A			Outdoor Unit
1	EEPROM outdoor unit faulty	EEPROM outdoor unit motherboard faulty	2	1	F12	15	F12	S	L	S	15	21	
2	Power module protection	The alarm goes out 3 times in an hour and locks the machine	2	2	F1	16	F1	A	L	L	16	22	
3	AC overcurrent protection / reversed phase sequence	Overcurrent / faulty current control / phase sequence reversed (models ON OFF)	2	3	F22	17	F22	L	L	S	17	23	
4	Communication error between motherboard and SPDU/ISPM power module	Communication failure for more than 4 minutes between motherboard and SPDU/ISPM power module	2	4	F3	18	F3	S	L	S	18	24	
5	Compressor over current / high pressure	The alarm goes out 3 times in an hour and locks the machine.	2	5	F20	19	F20	S	L	A	19	25	
6	Voltage too low / too high	Voltage above 270 V or less than 187 V	2	6	F19	1A	F19	S	L	A	1A	26	
7	Locked compressor	The alarm goes out 3 times in an hour and locks the machine.	2	7	F27	1B	F27	S	L	S	1B	27	
8	Compressor delivery high temperature protection	Delivery temperature above 120°. The alarm goes out 3 times in an hour and locks the machine.	2	8	F4	1C	F4	S	L	S	1C	28	
9	Outdoor unit DC fan motor faulty	The alarm goes out 3 times in an hour and locks the machine.	2	9	F8	1D	F8	S	L	A	1D	29	
10	Outdoor unit defrosting temperature probe faulty	Temperature probe in short circuit or open circuit within last 60 seconds	3	0	F21	1E	F21	A	A	L	1E	30	
11	Compressor intake temperature probe faulty	Temperature probe in short circuit or open circuit within last 60 seconds	3	1	F7	1F	F7	S	L	S	1F	31	
12	Outdoor unit ambient temperature probe faulty	Temperature probe in short circuit or open circuit within last 60 seconds	3	2	F6	20	F6	A	L	S	20	32	
13	Compressor delivery temperature probe faulty	Temperature probe in short circuit or open circuit within last 60 seconds	3	3	F25	21	F25	L	A	S	21	33	
15	Communication error between indoor and outdoor units	Lack of communication for more than 4 consecutive minutes	3	5	E7	23	E7	S	S	L	07	35	
16	Lack of refrigerant / clogging of refrigerant delivery tube	It reports an error and stops if it detects Td-Tci>=25 for 1 minute after the compressor starts in cooling operating mode for 10 min. The alarm goes out after 3 times in an hour and locks the machine.	3	6	F13	24	F13	S	L	A	24	36	
17	4-way valve switching failure	4-way valve coil damaged, disconnected or unpowered. Mechanical failure of the 4-way valve.	3	7	F14	25	F14				25	37	
18	Loss of compressor synchronism detection	Inverter / compressor circuit failure	3	8	F11	26	F11	S	L	S	26	38	
19	Compressor overcurrent at fixed frequency (software threshold)	The alarm goes out 3 times in an hour and locks the machine.	3	9	F28	27	F28	S	L	S	27	39	
20	Protection of indoor unit piping too high	Check heat exchange / refrigerant charge / sensors / electronic board	4	0	E9	28	E9				28	40	Indoor Unit
20	Board/terminal overheating protection	Short circuit / overheating on components	4	0	F15	28	F15	S	L	A	28	40	Outdoor Unit

Continuing →

Alarm on outdoor unit display /led	Description of the alarm	Description / Cause	Indoor units: ducted cassette ceiling/floor conv. console		Indoor unit panel display: ceiling/ floor conv. console	Display ducted cassette	Wall-mounted unit				Alarm on wired controller YR-E17A HW-SA201ABK HW-BA116ABK HW-BA101ABT	Alarm on wired controller YR-E16B HW-PA201ABK	Failure on indoor/ outdoor unit
			Timer (yellow)	Operate /run (green)			Display	Power	Timer	Operate			
21	Protection of indoor unit piping too high	Check heat exchange / refrigerant charge / sensors / electronic board	4	0	E9	28	E9	A	S	L	28	40	Indoor Unit
22	Indoor unit ice protection	Indoor unit exchanger temperature too low	0	16	E5	10	E5	A	S	L	10	16	
23	SPDU/ISPM power module temperature protection	SPDU/ISPM module temperature too high. The alarm goes out 3 times in an hour and locks the machine.	4	3	F5	2B	F5				2B	43	
24	Failed to start compressor / Overcurrent	The alarm goes out 3 times in an hour and locks the machine.	4	4	F2	2C	F2	S	L	A	2C	44	Outdoor Unit
25	U-V-W compressor phase overcurrent / Module input overcurrent	Unbalanced phases, damaged windings on the compressor, power module	4	5	F23	2D	F23	S	L	A	2D	45	
26	Power module reset	Reset the faulty system / power module	4	6	F9	2E	F9				2E	46	
27	No charge/faulty amperometric control	Detached compressor cables / faulty amperometric control	4	7	F24	2F	F24	L	S	L	2F	47	
*28	Gas shortage or piping obstruction	Check refrigerant charge / refrigerant circuit obstructions											
28	Liquid pipe circuit "A" temperature probe faulty	Sensor disconnected, broken, or poorly positioned	4	8	F10	30	F10	S	L	A	30	48	
29	Liquid pipe circuit "B" temperature probe faulty	Sensor disconnected, broken, or poorly positioned	4	9	F16	31	F16	S	L	A	31	49	
30	Liquid pipe circuit "C" temperature probe faulty	Sensor disconnected, broken, or poorly positioned	5	0	F17	32	F17	S	L	A	32	50	
31	Liquid pipe circuit "D" temperature probe faulty	Sensor disconnected, broken, or poorly positioned	5	1	F18	33	F18	S	L	A	33	51	
32	Gas pipe circuit "A" temperature probe faulty	Sensor disconnected, broken, or poorly positioned	5	2	F29	34	F29	S	L	A	34	52	
33	Gas pipe circuit "B" temperature probe faulty	Sensor disconnected, broken, or poorly positioned	5	3	F30	35	F30	S	L	A	35	53	
34	Gas pipe circuit "C" temperature probe faulty	Sensor disconnected, broken, or poorly positioned	5	4	F31	36	F31	S	L	A	36	54	
35	Gas pipe circuit "D" temperature probe faulty	Sensor disconnected, broken, or poorly positioned	5	5	F32	37	F32	S	L	A	37	55	
36	Gas pipe circuit "E" temperature probe faulty	Sensor disconnected, broken, or poorly positioned	5	6	F26	38	F26	S	L	A	38	56	
37	Outdoor exchanger temperature protection	Heat exchange problems/ temperature probe failure	5	7	F34	39	F34				39	57	
38	Power module temperature sensor failure	Sensor disconnected, broken, or poorly positioned / power module failure	5	8	F35	3A	F35	S	L	A	3A	58	
39	Piping temperature probe "TC" faulty	Sensor disconnected, broken, or poorly positioned	5	9	F36	3B	F36	S	L	A	3B	59	
40	Liquid pipe circuit "E" temperature probe faulty	Sensor disconnected, broken, or poorly positioned	6	0	F33	3C	F33				3C	60	
42	High pressure switch alarm	High pressure switch unplugged/faulty/excessive refrigerant	6	2	F39	3E	F39	S	L	A	3E	62	
43	Low pressure switch alarm	Low pressure switch unplugged/faulty/lack of refrigerant	6	3	F40	3F	F40	S	L	A	3F	63	
44	Temperature protection of outdoor heat exchanger TC too high	Operating temperature too high, heat exchange problems, excessive refrigerant	6	4	F41	40	F41				40	64	
45	Low system pressure protection	Operating temperature too low, heat exchange problems, low refrigerant	6	5	F42	41	F42				41	65	
46	Indoor - outdoor unit communication protocol incorrect	Indoor - outdoor unit communication problem (check OU-IU compatibility)	6	6	F43	42	F43				42	66	



































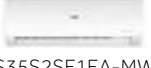
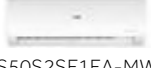
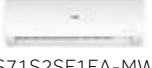

















Alarm on outdoor unit display / led	Description of the alarm	Description / Cause	Indoor unit electronic board LED		Indoor unit panel display:	Alarm on wired controller YR-E17A HW-SA201ABK HW-BA116ABK HW-BA101ABT	Alarm on wired controller YR-E16B HW-PA201ABK
			LED6	LED1			
	Indoor unit ambient temperature probe faulty	Faulty sensor or short-circuit for more than 2 consecutive minutes.	0	1	E1	01	1
	Indoor unit exchanger temperature probe faulty.	Faulty sensor or short-circuit for more than 2 consecutive minutes.	0	2	E2	02	2
	EEPROM faulty indoor unit board	EEPROM faulty indoor unit board	0	4	E4	04	4
	Indoor unit ice protection	Indoor unit exchanger temperature too low	0	16	E5	10	16
	Outdoor unit high pressure	High pressure, damaged high-pressure switch, faulty electronic board	0	6	E6	06	2
	Overcurrent protection	Abnormal supply voltage or faulty electronic board	0	7	E7	07	7
	Communication error between control panel and indoor unit electronic board	Poor connection, faulty panel board or electronic board	0	8	E8	08	8
	Communication error between indoor and outdoor units	Wrong connection, faulty indoor/outdoor unit electronic board	0	9	E9	08	9
	Indoor unit DC fan motor faulty	DC motor wiring interrupted, motor failure, electronic board damaged	0	14	EA	0E	14
	High temperature on the compressor	Damaged compressor, faulty compressor probe, electronic board	0	/	FC		
2	IPM hardware (power module) overcurrent	The alarm goes out 3 times in an hour and locks the machine	2	2	F02	16	22
3	Compressor overcurrent during deceleration	Overcurrent / faulty current control / phase sequence reversed (models ON OFF)	2	3	F03	17	23
4	Abnormal communication between the control board and the compressor power module	Communication failure for more than 4 minutes between motherboard and SPDU/ISPM power module	2	4	F04	18	24
5	Compressor overcurrent detected by control board	The alarm goes out 3 times in an hour and locks the machine.	2	5	F05	19	25
6	High DC voltage or AC voltage	Voltage above 270 V or less than 187 V	2	6	F06	1A	26
7	Compressor current sampling circuit failure	The alarm goes out 3 times in an hour and locks the machine.	2	7	F07	1B	27
8	Compressor discharge temperature protection too high	Delivery temperature above 120°. The alarm goes out 3 times in an hour and locks the machine.	2	8	F08	1C	28
8	Outdoor unit exchanger probe failure	Check interrupted or faulty probe			E4		
9	DC fan motor failure	The alarm goes out 3 times in an hour and locks the machine.	2	9	F09	1D	29
10	Outdoor unit defrosting temperature probe faulty (Te)	Temperature probe in short circuit or open circuit within last 60 seconds	3	0	F10	1E	30
11	Compressor intake temperature probe faulty (Ts)	Temperature probe in short circuit or open circuit within last 60 seconds	3	1	F11	1F	31
12	Outdoor unit ambient temperature probe faulty (Ta)	Temperature probe in short circuit or open circuit within last 60 seconds	3	2	F12	20	32
13	Compressor delivery temperature probe faulty (Td)	Temperature probe in short circuit or open circuit within last 60 seconds	3	3	F13	21	33
14	PFC circuit voltage too high	DC voltage too high on the inverter module	3	4	F14	22	34
15	Communication error between indoor and outdoor units	Lack of communication for more than 4 consecutive minutes	3	5	F15	23	35
16	Lack of refrigerant / clogging of refrigerant delivery tube	It reports an error and stops if it detects $T_d - T_{ci} > 25^{\circ}\text{C}$ for 1 minute after the compressor starts in cooling operating mode for 10 min. The alarm goes out after 3 times in an hour and locks the machine.	3	6	F16	24	36
17	4-way valve switching failure	4-way valve coil damaged, disconnected or unpowered. Mechanical failure of the 4-way valve.	3	7	F17	25	37
18	Loss of compressor synchronism detection	Inverter / compressor circuit failure	3	8	F18	26	38
19	DC voltage or AC voltage low / PWM selection circuit error in the power module.	The alarm goes out 3 times in an hour and locks the machine.	3	9	F19	27	39

Alarm on outdoor unit display / led	Description of the alarm	Description / Cause	Indoor unit electronic board LED		Indoor unit panel display:	Alarm on wired controller YR-E17A HW-SA201ABK HW-BA116ABK HW-BA101ABT	Alarm on wired controller YR-E16B HW-PA201ABK
			LED6	LED1			
20	Temperature protection of indoor pipe too high	Check heat exchange / refrigerant charge / sensors / electronic board	4	0	F20	28	40
21	Temperature protection of indoor pipe too low	Check heat exchange / refrigerant charge / sensors / electronic board	4	1	F21	29	41
22	PFC circuit overcurrent	DC overcurrent at the power module	4	2	F22	2A	42
23	Temperature too high for the power module	SPDU/ISPM module temperature too high. The alarm goes out 3 times in an hour and locks the machine.	4	3	F23	2B	43
24	Failed to start compressor / Overcurrent	The alarm goes out 3 times in an hour and locks the machine.	4	4	F24	2C	44
25	U-V-W compressor phase overcurrent / Module input overcurrent	Unbalanced phases, damaged windings on the compressor, power module	4	5	F25	2D	45
26	Lack of a phase in the power module	System reset / compressor phase check / power module failure	4	6	F26	2E	46
27	Input current verification circuit failure	Detached compressor cables / faulty amperometric control	4	7	F27	2F	47
28	No charge/faulty amperometric control	Check compressor - power module wiring	4	8	F28	30	48
37	Compressor overcurrent detected by power module	Verify voltage to power module - faulty module	5	7	F37	39	57
38	Power module temperature sensor failure	Sensor disconnected, broken, or poorly positioned / power module failure	5	8	F38	3A	58
39	Heat exchanger temperature sensor (TC) failure	Sensor disconnected, broken, or poorly positioned	5	9	F39	3B	59
42	High pressure switch alarm	High pressure switch unplugged/faulty/excessive refrigerant	6	2	F42	3E	62
43	Low pressure switch alarm	Low pressure switch unplugged/faulty/lack of refrigerant	6	3	F43	3F	63
44	Temperature protection of outdoor heat exchanger TC too high	Operating temperature too high, heat exchange problems, excessive refrigerant	6	4	F44	40	64
45	Low system pressure protection	Operating temperature too low, heat exchange problems, low refrigerant	6	5	F45	41	65

MONO SPLIT UNITS

Pearl R290	39
Expert Nordic	44
Pearl Nordic	47
Flair	49
Ducted High Pressure R32	52
Ducted High Pressure R410A	53
AHU Solution	57
Tower	60
Cabinet	63

RESIDENTIAL & LIGHT COMMERCIAL MONOSPLIT

SERIES		2,5 kW	3,5 kW	4.2 kW	5.0 kW	7.1 kW
PEARL R290	 AS25PBBHRA	 AS35PBBHRA				
	 1U25YEBGRA	 1U35YEBGRA				
JADE	 AS25S2SJ1FA-3	 AS35S2SJ1FA-3				
	 1U25MECFRA-3	 1U35MECFRA-3				
EXPERT WHITE/BLACK	 AS25XCAHRA	 AS35XCAHRA			 AS50XCAHRA	 AS71XCAHRA
	 AS25XCAHRA-MB	 AS35XCAHRA-MB			 AS50XCAHRA-MB	 AS71XCAHRA-MB
	 1U25S2SM1FA-2	 1U35S2SM1FA-2			 1U50S2SJ2FA-2	 1U71S2ST1FA
EXPERT NORDIC	 AS25XCHHRA-NR	 AS35XCHHRA-NR				
	 1U25KEHFRA-NR	 1U35KEHFRA-NR				
FLEXIS PLUS WHITE/BLACK	 AS25S2SF1FA-MW3	 AS35S2SF1FA-MW3			 AS50S2SF1FA-MW3	 AS71S2SF1FA-MW3
	 AS25S2SF1FA-MB3	 AS35S2SF1FA-MB3			 AS50S2SF1FA-MB3	 AS71S2SF1FA-MB3
	Ou Standard  1U25S2SM1FA-2	 1U35S2SM1FA-2			 1U50S2SJ2FA-2	 1U71S2ST1FA
	Ou Nordic  1U25MEHFRA-1	 1U35MEHFRA-1			 1U50KEFFRA-1	
NEW PEARL PREMIUM	 AS25PBPBPHRA-PRE	 AS35PBPBPHRA-PRE			 AS50PDPHRA-PRE	 AS71PEPHRA-PRE
	 1U25YEPFRA-PRE	 1U35MEPFRA-PRE			 1U50KEPFRA-PRE	 1U71WEPFRA-PRE
NEW REVIVE PLUS	 AS25RBAHRA-3	 AS35RBAHRA-4			 AS50RCBHRA-4	 AS68RDAHRA-4
	 1U25YEGFRA-3	 1U35YESFRA-4			 1U50MERFRA-4	 1U68MRAFRA-4

RESIDENTIAL & LIGHT COMMERCIAL MONOSPLIT

SERIES		2,5 kW	3,5 kW	4.2 kW	5.0 kW	7.1 kW
NEW PEARL NORDIC		AS25PCHHRA-NR	AS35PCHHRA-NR		AS50PDHHRA-NR	
		1U25KEFFRA-NR	1U35KEFFRA-NR		1U50WEFFRA-NR	
CONSOLE						
	Ou Standard					
	Ou Nordic					
1-WAY CASSETTE						
CASSETTE 620						
CEILING FLOOR						
SLIM DUCT LOW PRESSURE						
DUCTED MEDIUM PRESSURE						
TOWER						

The expressed kW/Btu is for cooling classification. For exact values, see the technical data tables of the individual models.

The data in this catalogue is purely indicative as the data may vary. Please be advised to check the accuracy of the data with the supplier before purchasing products.

LIGHT COMMERCIAL MONOSPLIT

SERIES	10.5 kW	12.5 kW	14 kW	16 kW	20kW	25 kW
FLAIR	 AS105S2SF2FA-2					
	 1U105S2SS2FA					
ROUND FLOW CASSETTE	 ABH105H1ERG(H)	 ABH125K1ERG(H)	 ABH140K1ERG(H)	 ABH160K1ERG(H)		
	 1U105S2SS2FA 1U105S2SS1FB	 1U125S2SN2FA 1U125S2SN2FB	 1U140S2SN1FA 1U140S2SN1FB 1U140S2SP2FA 1U140S2SP2FB	 1U160S2SP1FB		
CEILING FLOOR	 AC105S2SH1FA(H)	 AC125S2SK1FA(H)	 AC140S2SK1FA(H)	 AC160S2SK1FA(H)		
	 1U105S2SS2FA 1U105S2SS1FB	 1U125S2SN2FA 1U125S2SN2FB	 1U140S2SN1FA 1U140S2SN1FB 1U140S2SP2FA 1U140S2SP2FB	 1U160S2SP1FB		
DUCTED MEDIUM PRESSURE	 AD105S2SM3FA(H)	 AD125S2SM8FA(H)	 AD140S2SM8FA(H)	 AD160S2SM3FA(H)		
	 1U105S2SS2FA 1U105S2SS1FB	 1U125S2SN2FA 1U125S2SN2FB	 1U140S2SN1FA 1U140S2SN1FB 1U140S2SP2FA 1U140S2SP2FB	 1U160S2SP1FB		
DUCTED HIGH PRESSURE		 ADH125H1ERG	 ADH140H1ERG	 ADH160H1ERG*	 ADH200H1ERG	 ADH250H1ERG
		 1U125S2SN2FA 1U125S2SN2FB	 1U140S2SN1FA 1U140S2SN1FB 1U140S2SP2FA 1U140S2SP2FB	 1U160S2SP1FB*	 1UH200W1ERK	 1UH250W1ERK

Indoor-outdoor units

AS25PBBHRA / 1U25YEBGRA (2.5 kW)

AS35PBBHRA / 1U35YEBGRA (3.5 kW)

CIRCUIT DIAGRAM 2.5 KW - 3.5 KW

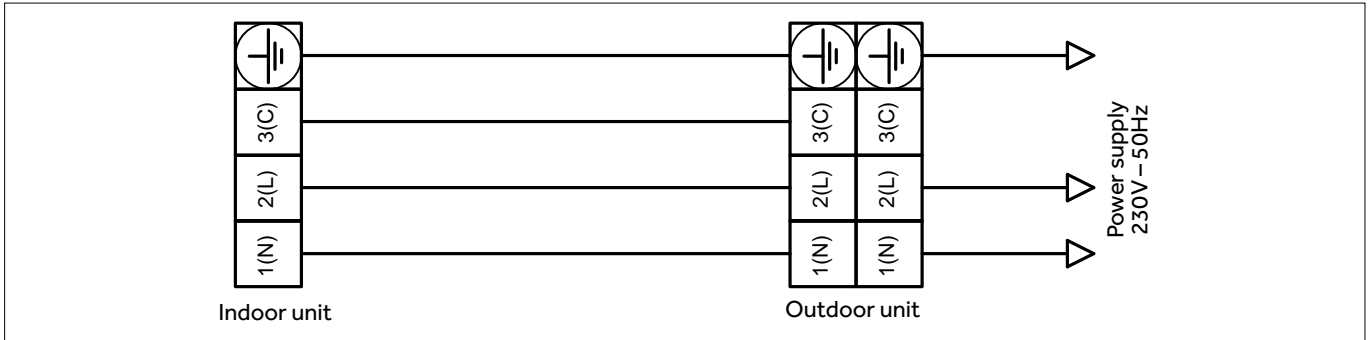

INDOOR UNIT MODEL			AS25PBBHRA	AS35PBBHRA
OUTDOOR UNIT MODEL			1U25YEBGRA	1U35YEBGRA
Indoor unit technical data				
Treated air volume	H	m ³ /h	580	650
Net dimensions	WxDxH	mm	805x200x292	805x200x292
Net / gross weight		kg	8,3 / 10,6	8,3 / 10,6
Outdoor unit technical data				
Liquid pipe Ø		mm (inch)	6,35 (1/4)	6,35 (1/4)
Gas pipe Ø		mm (inch)	9,52 (3/8)	9,52 (3/8)
Standard pipe length without refrigerant charge		m	10	10
Maximum pipe length		m	10	10
Minimum pipe length		m	5	5
Power Supply		Ph / V / Hz	1 / 220-240 / 50	1 / 220-240 / 50
Net / gross weight		kg	24,5 / 27	24,5 / 27
Additional ref. charge over std length		g/m	No additional charge allowed.	

DIAGNOSTICS

For diagnostics, see **pages 30 - 31**.

INDOOR UNIT CIRCUIT DIAGRAM 2.5 KW - 3.5 KW

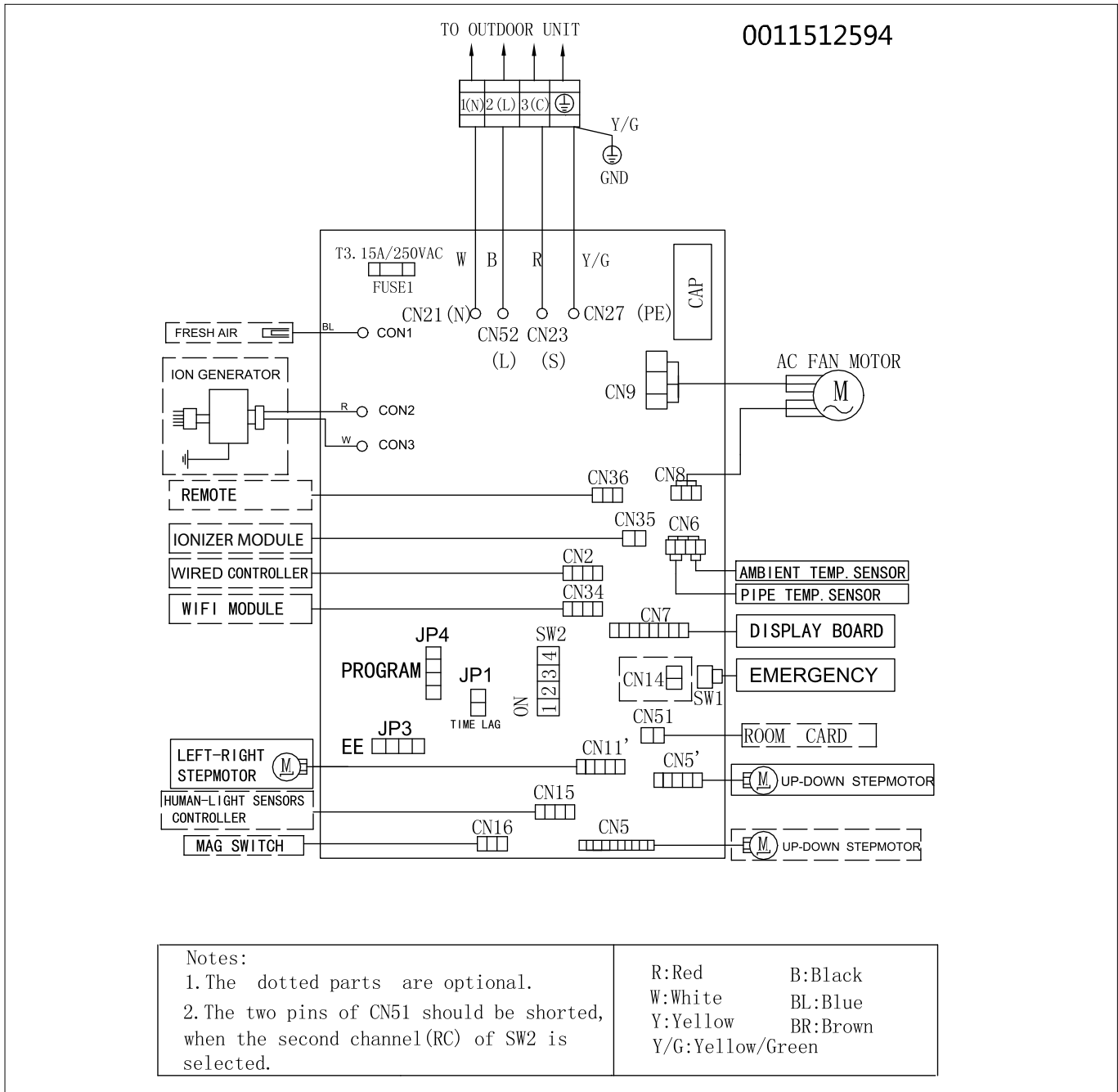

INDOOR UNIT SETTINGS 2.5 KW - 3.5 KW

Selecting the frequency of remote control A or B (SW2-1):

Switch 1 selects the working frequency of the remote control of the indoor wall unit, from "A" to "B".
Set the same frequency on the remote control.

- OFF** operating frequency "A"
- ON** operating frequency "B"

Selecting the room-card (indoor unit activation board) (SW2-2):

Using switch 2, you can select the operating mode of the room-card (CN51), which is a clean contact where components (e.g. window contact) can be applied, so as to be able to manage the switching on and/or off of the indoor units in the system:

- OFF** With open contact the unit stops and with closed contact the unit starts (even if it was previously turned off) in the last mode used.
With outdoor contact open, the local controller can turn the unit on/off.
- ON** With open contact the unit stops, and with closed contact the unit is ready to start (it is turned on by remote control).
With outdoor contact open, the controller cannot control the unit.

Selecting the indoor unit power (SW2-3) and (SW2-4):

Using switches 3 and 4 you can select the power of the indoor unit:

	3.5 kW	2.5 kW
SW2-3	OFF	OFF
SW2-4	ON	OFF

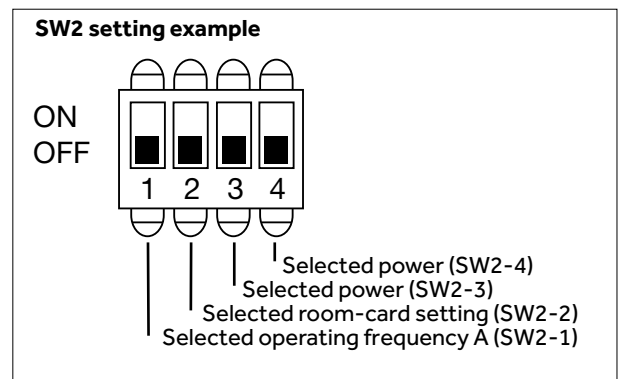

Important: Cut the jumpers **J1, J2** on board depending on the split on which the electronic board will be installed. (already cut in factory depending on the model).

This procedure is essential in order for the main board to communicate correctly with the receiving display/board.

	PEARL
J1	ON
J2	OFF

Selecting the ambient temperature/set-point on the display: To switch the display between real temperature and ambient set-point, press the LIGHT key of the remote control 10 times. The indoor unit will respond with: 2 BEEP sounds to display ambient temperature, 4 BEEP sounds to display set-point temperature.

Activating/deactivating power-saving feature of the fan motor in cooling mode:

Directing the remote control to the indoor unit:

1. Press the "AUTO" (or "SMART") key
2. Press the "HEALTH" key 6 times

The indoor unit will respond with 2 "BEEP" sounds and the eco function will be disabled.
The fan will always be in operation, even if the set ambient temperature is reached.

By repeating steps 1 and 2, the indoor unit will respond with 4 "BEEP" sounds and the eco function will be reactivated.
The fan will be stopped when the set ambient temperature is reached.

OU CIRCUIT DIAGRAM 2.5 KW - 3.5 KW

COOLING MODE

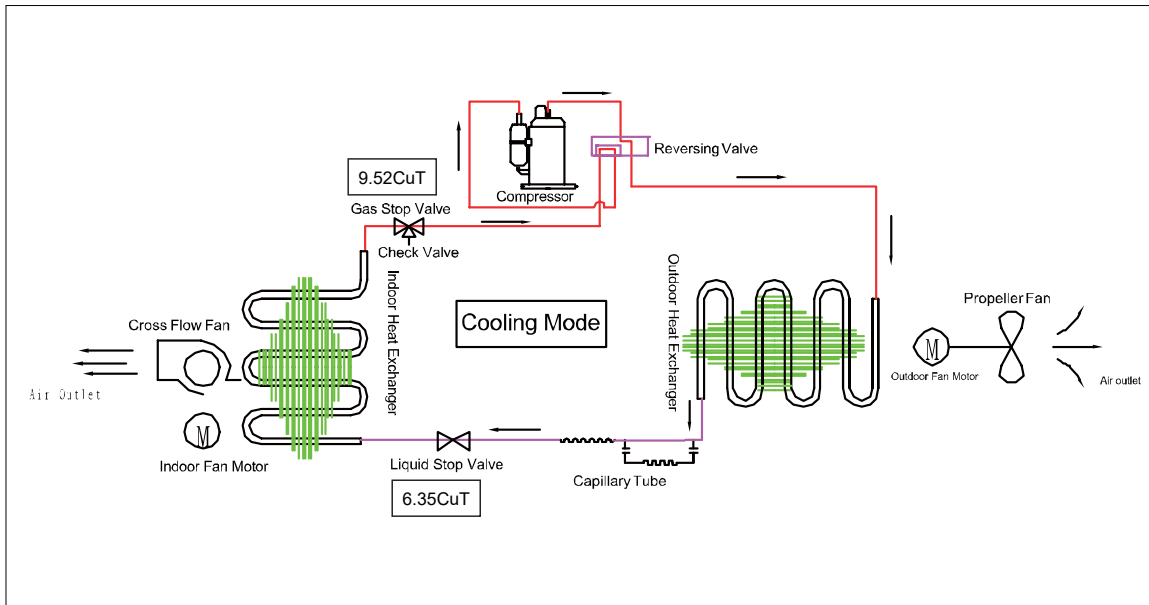

HEATING MODE

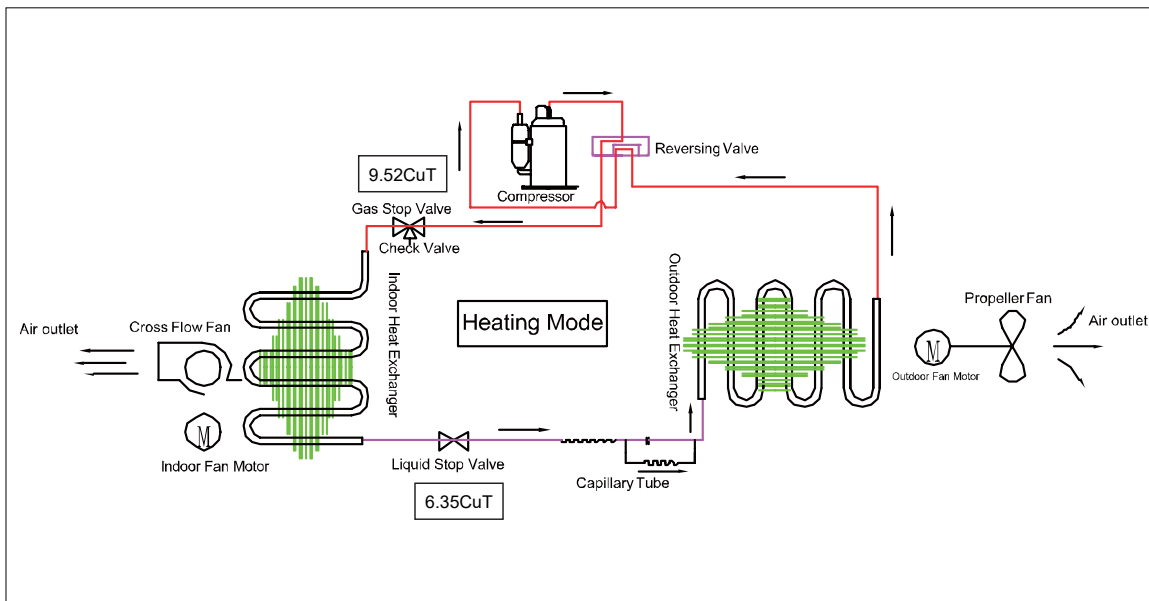

PRINTED CIRCUIT BOARD CONNECTOR WIRING DIAGRAM

CONNECTORS

PCB(1) (Control PCB)

1. CN9 Connector for fan motor
2. CN6 Connector for heat exchanger thermistor and Room temperature thermistor
3. CN5' Connector for UP&DOWN STEP motor
4. CN11 CN11' Connector for RIGHT&LEFT STEP motor
5. CN21 (white line) CN52 (black line) Connector for indoor terminal N and L
6. CN7 Connector for display board
7. CON2 CON3 Connector for ion generator
8. CN23 (red line) Connector for communicate between the indoor board and the outdoor board
9. CN36 Connector for long-range control
10. CN34 Connector for wifi Module
11. CON1 Connector for fresh air
12. CN2 Connector for wired controller
13. CN51 Connector for room card
14. CN1 Connector for UV Lamp
15. CN3 Connector for magnetic switc

NOTE: OTHER DESIGNATIONS

PCB(1) (Indoor Control PCB)

1. CN14 Connector for Forced operation ON / OFF switch
2. FUSE1 Fuse 3.15A/250VAC
3. Pin-1: OFF-match A code remote control; ON-match B code remote control
Pin-2: OFF-no room card control; ON-with room card control
Pin-3 and Pin-4 combined control, corresponding to 23, 26,33and35of the machine respectively
4. Jumper J1 and J2 combined control, corresponding to different series of display boards;
ON means keep; OFF means cut

	OFF	ON	3	ON	ON	OFF	OFF
1	A	B	4	ON	OFF	ON	OFF
2	N_RC	RC		35	33	26	23

J1	OFF	OFF	ON	ON
J2	OFF	ON	OFF	ON
DISPLAY SERIES	325/798	324	387/1045	317

UNIT MOUDLE	PCB MOUDLE	1	2	3	4	DISPLAY MOUDLE	J1	J2
AS25PBBHRA	0011801123(23□)	ON	ON	OFF	OFF	0011801045	ON	OFF

Indoor-outdoor units

AS25XCHHRA-NR / 1U25KEHFRA-NR (2.5 kW)

AS35XCHHRA-NR / 1U35KEHFRA-NR (3.5 kW)

INDOOR UNIT MODEL			AS25XCHHRA-NR	AS35XCHHRA-NR
OUTDOOR UNIT MODEL			1U25KEHFRA-NR	1U35KEHFRA-NR
Indoor unit technical data				
Treated air volume	H	m ³ /h	750	810
Net dimensions	WxDxH	mm	895x236x313	895x236x313
Net / gross weight		kg	12,4 / 14,8	12,4 / 14,8
Outdoor unit technical data				
Liquid pipe Ø		mm (inch)	6,35 (1/4)	6,35 (1/4)
Gas pipe Ø		mm (inch)	9,52 (3/8)	9,52 (3/8)
Standard pipe length without refrigerant charge		m	10	10
Maximum pipe length		m	10	10
Minimum pipe length		m	5	5
Power Supply		Ph / V / Hz	1 / 220-240 / 50	1 / 220-240 / 50
Net / gross weight		kg	24,5 / 27	24,5 / 27
Additional ref. charge over std length		g/m	No additional charge allowed.	

DIAGNOSTICS

For diagnostics, see **pages 30 - 31**.

See the list of alarms on **page 13**.

IU CIRCUIT DIAGRAM 2.5 KW - 3.5 KW

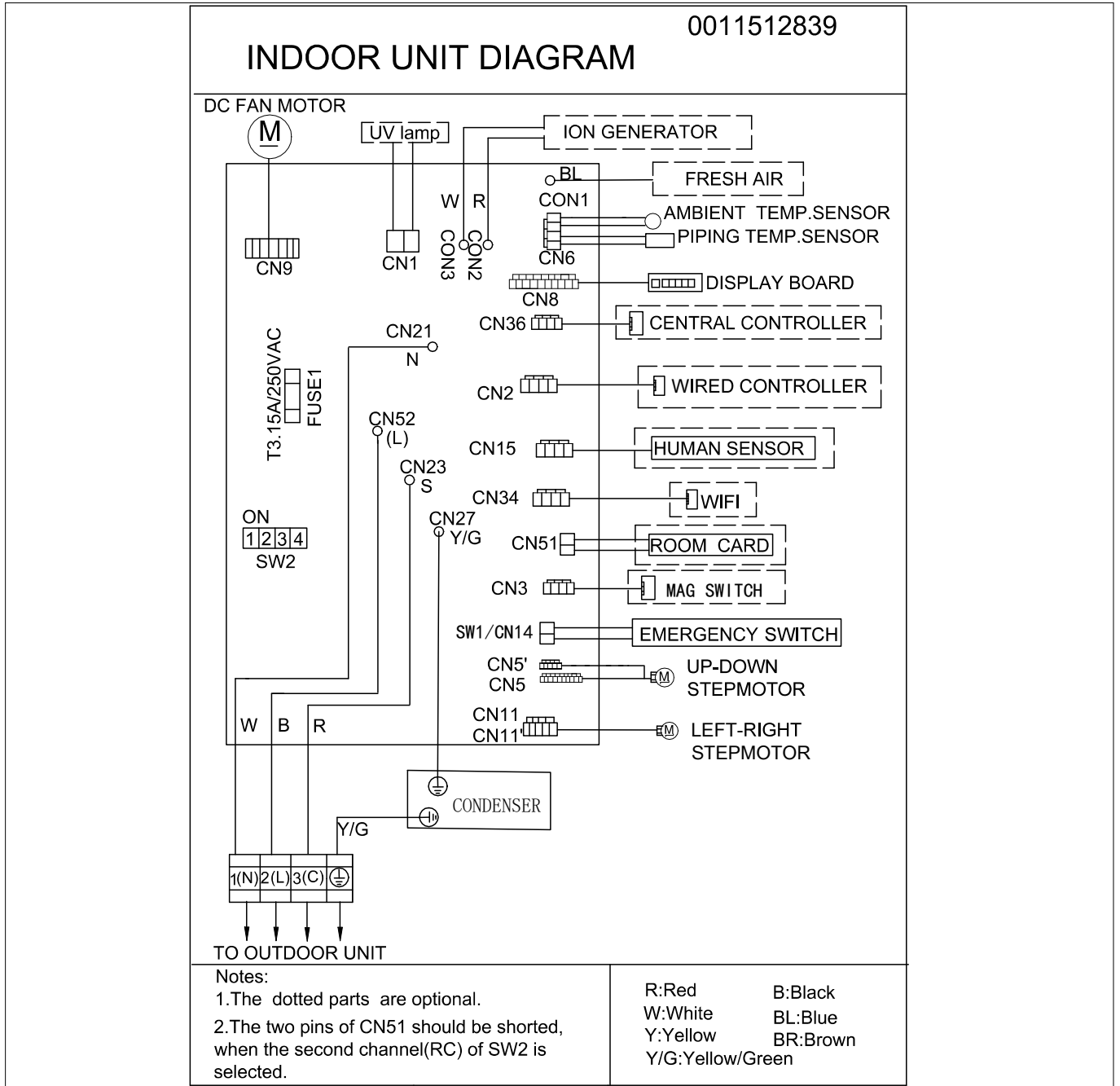

INDOOR UNIT SETTINGS 2.5 KW - 3.5 KW

Selecting the frequency of remote control A or B (SW2-1):

Switch 1 selects the working frequency of the remote control of the indoor wall unit, from "A" to "B".

Set the same frequency on the remote control.

OFF operating frequency "A"

ON operating frequency "B"

Selecting the room-card (indoor unit activation board) (SW2-2):

Using switch 2, you can select the operating mode of the room-card (CN51), which is a clean contact where components (e.g. window contact) can be applied, so as to be able to manage the switching on and/or off of the indoor units in the system:

OFF With open contact the unit stops and with closed contact the unit starts (even if it was previously turned off) in the last mode used.
With outdoor contact open, the local controller can turn the unit on/off.

ON With open contact the unit stops, and with closed contact the unit is ready to start (it is turned on by remote control).
With outdoor contact open, the controller cannot control the unit.

Selecting the indoor unit power (SW2-3) and (SW2-4):

Using switches 3 and 4 you can select the power of the indoor unit:

	2.5 kW	3.5 kW
SW2-3	OFF	OFF
SW2-4	OFF	ON

SW2 setting example

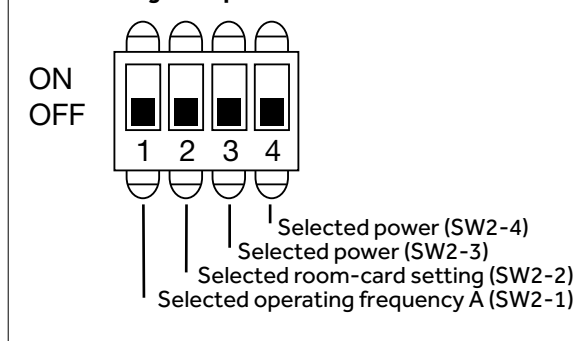

Important: Cut the jumpers **J1, J2** on board depending on the split on which the electronic board will be installed. (already cut in factory depending on the model).

This procedure is essential in order for the main board to communicate correctly with the receiving display/board.

	PEARL
J1	ON
J2	OFF

Selecting the ambient temperature/set-point on the display: To switch the display between real temperature and ambient set-point, press the LIGHT key of the remote control 10 times. The indoor unit will respond with: 2 BEEP sounds to display ambient temperature, 4 BEEP sounds to display set-point temperature.

Activating/deactivating power-saving feature of the fan motor in cooling mode:

Directing the remote control to the indoor unit:

5. Press the "AUTO" (or "SMART") key

6. Press the "HEALTH" key 6 times

The indoor unit will respond with 2 "BEEP" sounds and the eco function will be disabled.

The fan will always be in operation, even if the set ambient temperature is reached.

By repeating steps 1 and 2, the indoor unit will respond with 4 "BEEP" sounds and the eco function will be reactivated.

The fan will be stopped when the set ambient temperature is reached.

Indoor-outdoor units

AS25PCHHRA-NR - 1U25KEFFRA-NR (2.5 kW)

AS35PCHHRA-NR - 1U35KEFFRA-NR (3.5 kW)

AS50PDHHRA-NR - 1U50WEFFRA-NR (5.0 kW)

INDOOR UNIT MODEL			AS25PCHHRA-NR	AS35PCHHRA-NR	AS50PDHHRA-NR
OUTDOOR UNIT MODEL			1U25KEFFRA-NR	1U35KEFFRA-NR	1U50WEFFRA-NR
Indoor unit technical data					
Treated air volume	H	m ³ /h	620/615	680/660	800/830
Net dimensions	WxDxH	mm	875x217x307	875x217x307	975x220x318
Net / gross weight		kg	10,0 / 12,0	10,0 / 12,0	11,6 / 14,4
Outdoor unit technical data					
Liquid pipe Ø		mm (inch)	6,35 (1/4)	6,35 (1/4)	6,35 (1/4)
Gas pipe Ø		mm (inch)	9,52 (3/8)	9,52 (3/8)	12,7 (1/2)
Standard pipe length without refrigerant charge		m	7	7	7
Maximum pipe length		m	20	20	25
Minimum pipe length		m	5	5	5
Power Supply		Ph / V / Hz	1 / 220-240 / 50	1 / 220-240 / 50	1 / 220-240 / 50
Net / gross weight		kg	37,8 / 40,5	37,8 / 40,5	43,0 / 47,0
Additional ref. charge over std length		g/m	20	20	20

DIAGNOSTICS

For diagnostics, see **pages 30 - 31**.

See the list of alarms on **page 13**.

IU CIRCUIT DIAGRAM 2.5 KW - 3.5 KW - 5.0 KW

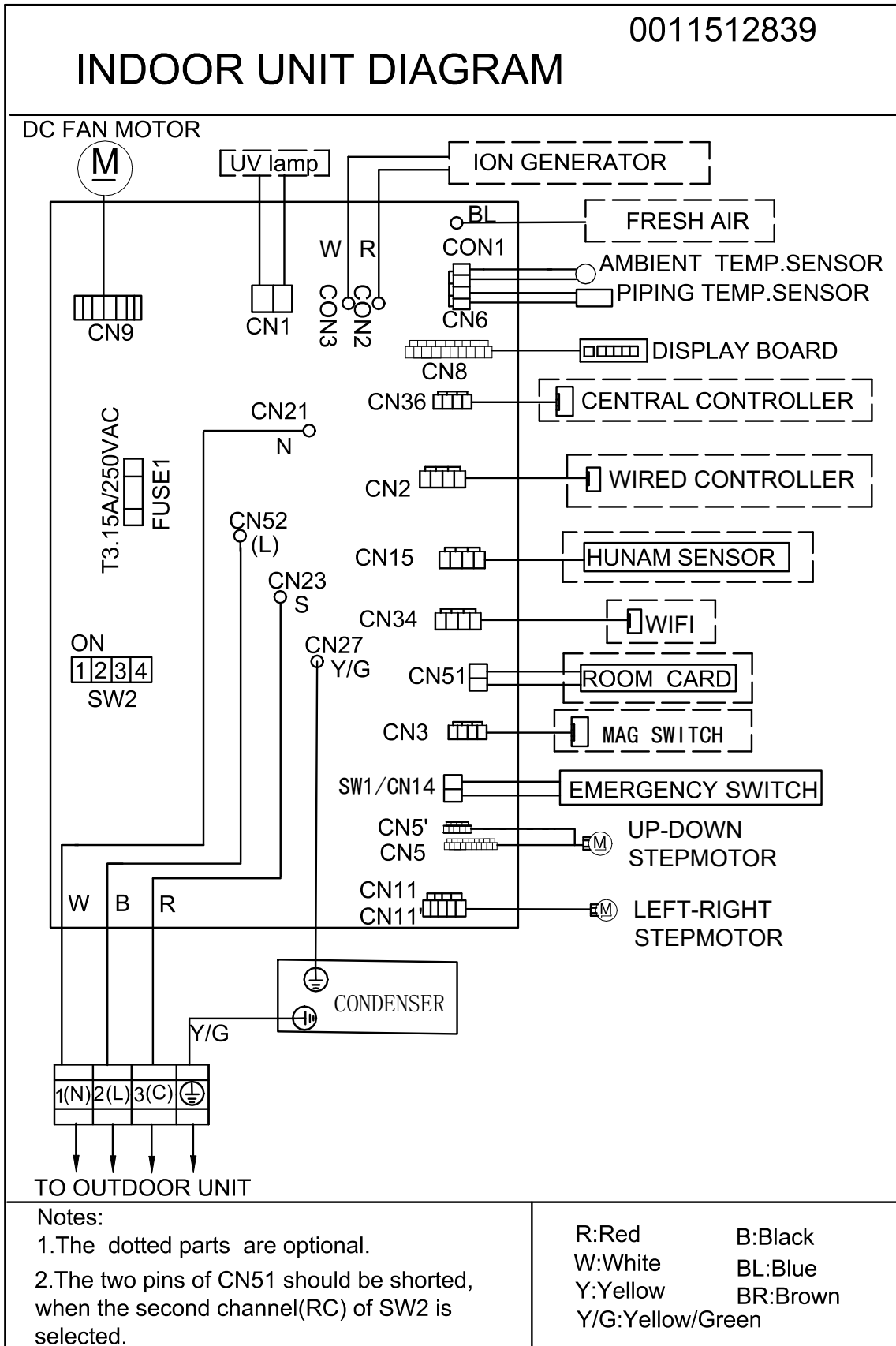

Indoor-outdoor units

AS105S2SF2FA-2 - 1U25MEHFRA-1 (2.5 kW)

INDOOR UNIT MODEL			AS105S2SF2FA-2
OUTDOOR UNIT MODEL			1U25MEHFRA-1
Indoor unit technical data			
Treated air volume	H	m ³ /h	1300
Net dimensions	WxDxH	mm	1342x275x365
Net / gross weight		kg	21,0 / 25,5
Outdoor unit technical data			
Liquid pipe Ø		mm (inch)	9,52 (3/8)
Gas pipe Ø		mm (inch)	15,88 (5/8)
Standard pipe length without refrigerant charge		m	7
Maximum pipe length		m	50
Minimum pipe length		m	5
Power Supply		Ph / V / Hz	1 / 220~240 / 50
Net / gross weight		kg	85,0 / 90,0
Additional ref. charge over std length		g/m	45

DIAGNOSTICS

For diagnostics, see **pages 30 - 31**.

See the list of alarms on **page 13**.

IU CIRCUIT DIAGRAM 2.5 KW

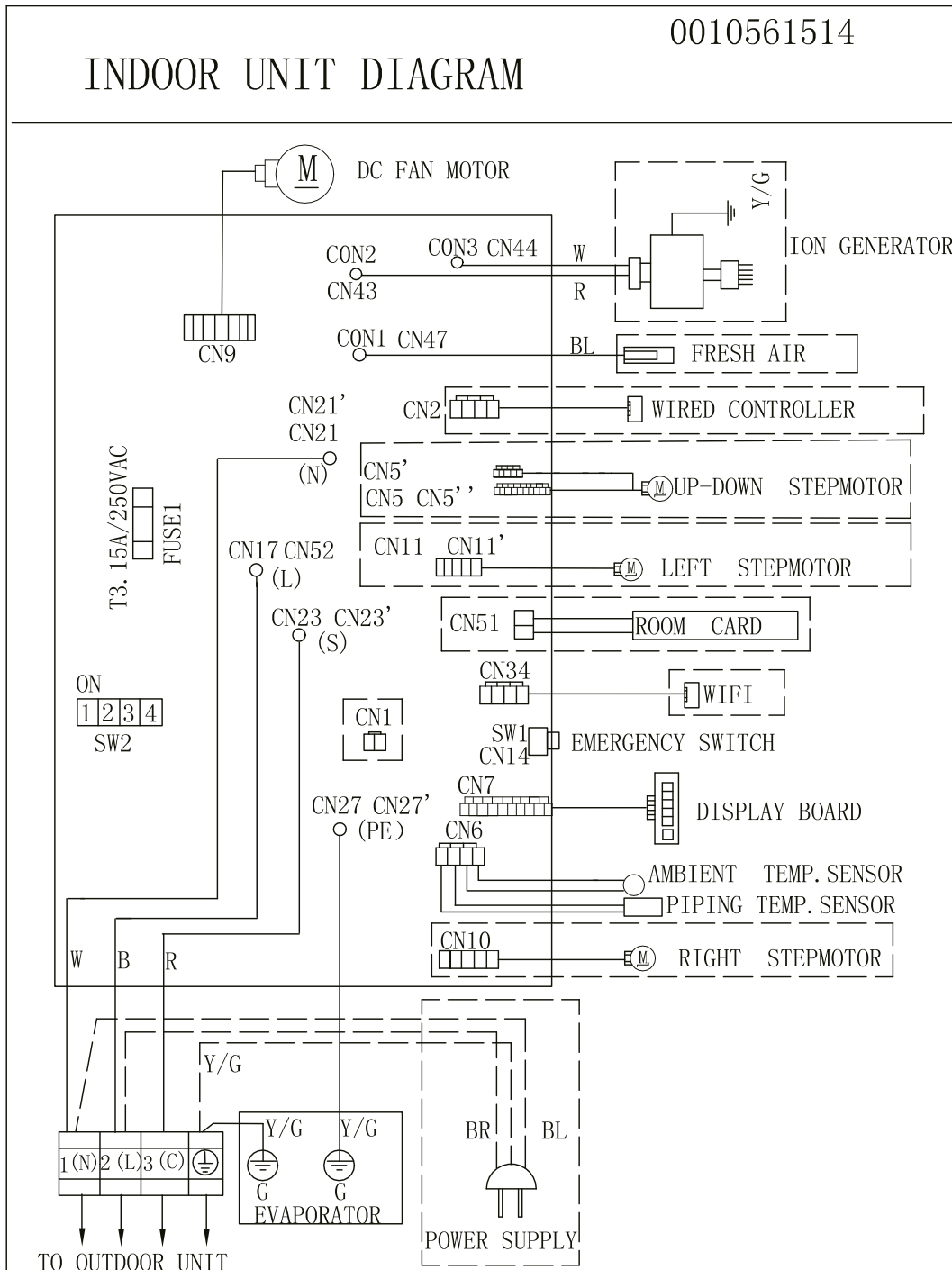

Notes:

1. The dotted parts are optional.
2. The two pins of CN51 should be shorted, when the second channel(RC) of SW2 is selected.

R:Red	B:Black
W:White	BL:Blue
Y:Yellow	BR:Brown
Y/G:Yellow/Green	

INDOOR UNIT SETTINGS 2.5 KW - 3.5 KW

Selecting the frequency of remote control A or B (SW2-1):

Switch 1 selects the working frequency of the remote control of the indoor wall unit, from "A" to "B".

Set the same frequency on the remote control.

OFF operating frequency "A"

ON operating frequency "B"

Selecting the room-card (indoor unit activation board) (SW2-2):

Using switch 2, you can select the operating mode of the room-card (CN51), which is a clean contact where components (e.g. window contact) can be applied, so as to be able to manage the switching on and/or off of the indoor units in the system:

OFF With open contact the unit stops and with closed contact the unit starts (even if it was previously turned off) in the last mode used.
With outdoor contact open, the local controller can turn the unit on/off.

ON With open contact the unit stops, and with closed contact the unit is ready to start (it is turned on by remote control).
With outdoor contact open, the controller cannot control the unit.

Selecting the indoor unit power (SW2-3) and (SW2-4):

Using switches 3 and 4 you can select the power of the indoor unit:

	2.5 kW	3.5 kW
SW2-3	OFF	OFF
SW2-4	OFF	ON

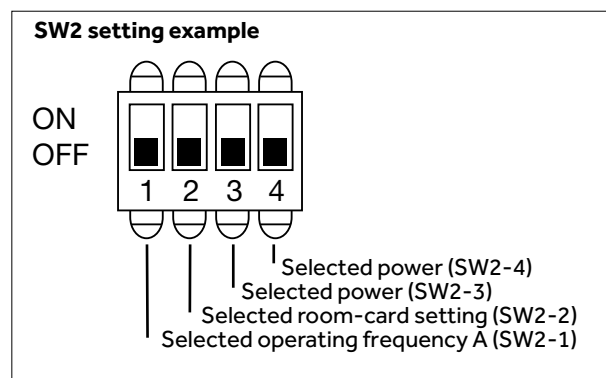

Important: Cut the jumpers **J1, J2** on board depending on the split on which the electronic board will be installed. (already cut in factory depending on the model).

This procedure is essential in order for the main board to communicate correctly with the receiving display/board.

	PEARL
J1	ON
J2	OFF

Selecting the ambient temperature/set-point on the display: To switch the display between real temperature and ambient set-point, press the LIGHT key of the remote control 10 times. The indoor unit will respond with: 2 BEEP sounds to display ambient temperature, 4 BEEP sounds to display set-point temperature.

Activating/deactivating power-saving feature of the fan motor in cooling mode:

Directing the remote control to the indoor unit:

7. Press the "AUTO" (or "SMART") key

8. Press the "HEALTH" key 6 times

The indoor unit will respond with 2 "BEEP" sounds and the eco function will be disabled.

The fan will always be in operation, even if the set ambient temperature is reached.

By repeating steps 1 and 2, the indoor unit will respond with 4 "BEEP" sounds and the eco function will be reactivated.

The fan will be stopped when the set ambient temperature is reached.

Indoor-outdoor units

ADH125H1ERG - 1U125S2SN2FA (12.5 kW)

ADH140H1ERG - 1U140S2SN1FA (14 kW)

ADH140H1ERG - 1U140S2SP2FA (14 kW)

ADH125H1ERG - 1U125S2SN2FB (12.5 kW)

ADH140H1ERG - 1U140S2SN1FB (14 kW)

ADH140H1ERG - 1U140S2SP2FB (14 kW)

ADH160H1ERG - 1U160S2SP1FB (16 kW)

INDOOR UNIT MODEL			ADH125H1ERG	ADH125H1ERG	ADH140H1ERG	ADH140H1ERG
OUTDOOR UNIT MODEL			1U125S2SN2FA	1U125S2SN2FB	1U140S2SN1FA	1U140S2SN1FB
Indoor unit technical data						
Treated air volume	H	m ³ /h	3250/2750/2250/1750	3250/2750/2250/1750	3600/3100/2600/2100	3600/3100/2600/2100
Net dimensions	WxDxH	mm	1350x490x425	1350x490x425	1350x490x425	1350x490x425
Net / gross weight		kg	61,0 / 72,0	61,0 / 72,0	61,0 / 72,0	61,0 / 72,0
Outdoor unit technical data						
Liquid pipe Ø		mm (inch)	9,52 (3/8)	9,52 (3/8)	9,52 (3/8)	9,52 (3/8)
Gas pipe Ø		mm (inch)	15,88 (5/8)	15,88 (5/8)	15,88 (5/8)	15,88 (5/8)
Standard pipe length without refrigerant charge		m	30	30	30	30
Maximum pipe length		m	50	50	70	70
Minimum pipe length		m	5	5	5	5
Power Supply		Ph / V / Hz	1 / 220-240 / 50	3 / 380-415 / 50/60	1 / 220-240 / 50	3 / 380-415 / 50/60
Net / gross weight		kg	37,8 / 40,5	85,0 / 90,0	84,0 / 89,0	85,0 / 90,0
Additional ref. charge over std length		g/m	45	45	45	45

INDOOR UNIT MODEL			ADH140H1ERG	ADH140H1ERG	ADH160H1ERG
OUTDOOR UNIT MODEL			1U140S2SP2FA	1U140S2SP2FB	1U160S2SP1FB
Indoor unit technical data					
Treated air volume	H	m ³ /h	3600/3100/2600/2100	3600/3100/2600/2100	4000/3400/2800/2200
Net dimensions	WxDxH	mm	1350x490x425	1350x490x425	1350x490x425
Net / gross weight		kg	61,0 / 72,0	61,0 / 72,0	61,0 / 72,0
Outdoor unit technical data					
Liquid pipe Ø		mm (inch)	9,52 (3/8)	9,52 (3/8)	9,52 (3/8)
Gas pipe Ø		mm (inch)	15,88 (5/8)	15,88 (5/8)	19,05 (3/4)
Standard pipe length without refrigerant charge		m	30	30	30
Maximum pipe length		m	70	70	70
Minimum pipe length		m	5	5	5
Power Supply		Ph / V / Hz	1 / 220-240 / 50	3 / 380-415 / 50 / 60	3 / 380-415 / 50 / 60
Net / gross weight		kg	105,0 / 118,0	101,0 / 116,0	101,0 / 116,0
Additional ref. charge over std length		g/m	45	45	60

DIAGNOSTICS

For diagnostics, see **pages 28 - 29**.

See the list of alarms on **page 14**.

Indoor-outdoor units

ADH200H1ERG - 1UH200W1ERK (200 kW)

ADH250H1ERG - 1UH250W1ERK (250 kW)

INDOOR UNIT MODEL		ADH200H1ERG	ADH250H1ERG	
OUTDOOR UNIT MODEL		1UH200W1ERK	1UH250W1ERK	
Indoor unit technical data				
Treated air volume	H	m ³ /h	4320/3780/3420/3060	5040/4500/3960/3600
Net dimensions	WxDxH	mm	1330x895x500	1330x895x500
Net / gross weight		kg	96	96
Outdoor unit technical data				
Liquid pipe Ø		mm (inch)	12,7 (1/2)	12,7 (1/2)
Gas pipe Ø		mm (inch)	19,05 (3/4)	22,22 (7/8)
Standard pipe length without refrigerant charge		m	30	30
Maximum pipe length		m	75	75
Minimum pipe length		m	5	5
Power Supply		Ph / V / Hz	3 / 380-400 / 50 / 60	3 / 380-400 / 50 / 60
Net / gross weight		kg	160	160
Additional ref. charge over std length		g/m	90	90

DIAGNOSTICS

For diagnostics, see **page 28 - 29**.

See the list of alarms on **page 14**.

CIRCUIT DIAGRAM 12.5 KW – 14 KW – 20 KW – 25 KW

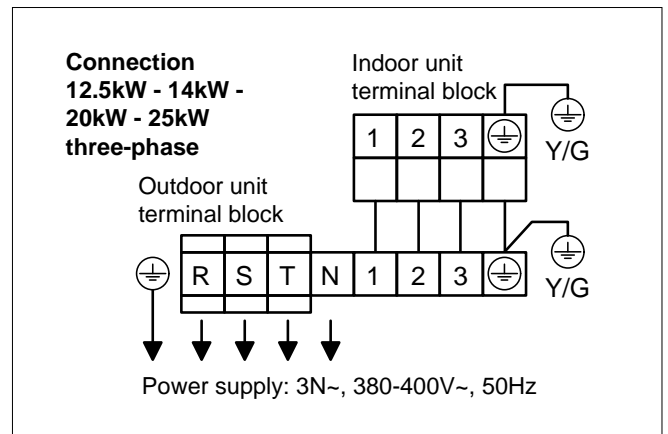
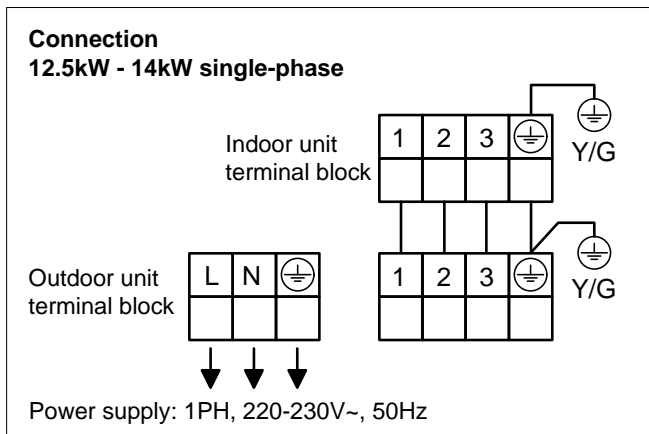

DIAGNOSTICS 12.5 KW - 14 KW - 20 KW - 25 KW

To see the list of alarms for the indoor units connected to MONO outdoor units, go to **pages 28 - 29**.

IU CIRCUIT DIAGRAM 12.5 KW - 14 KW

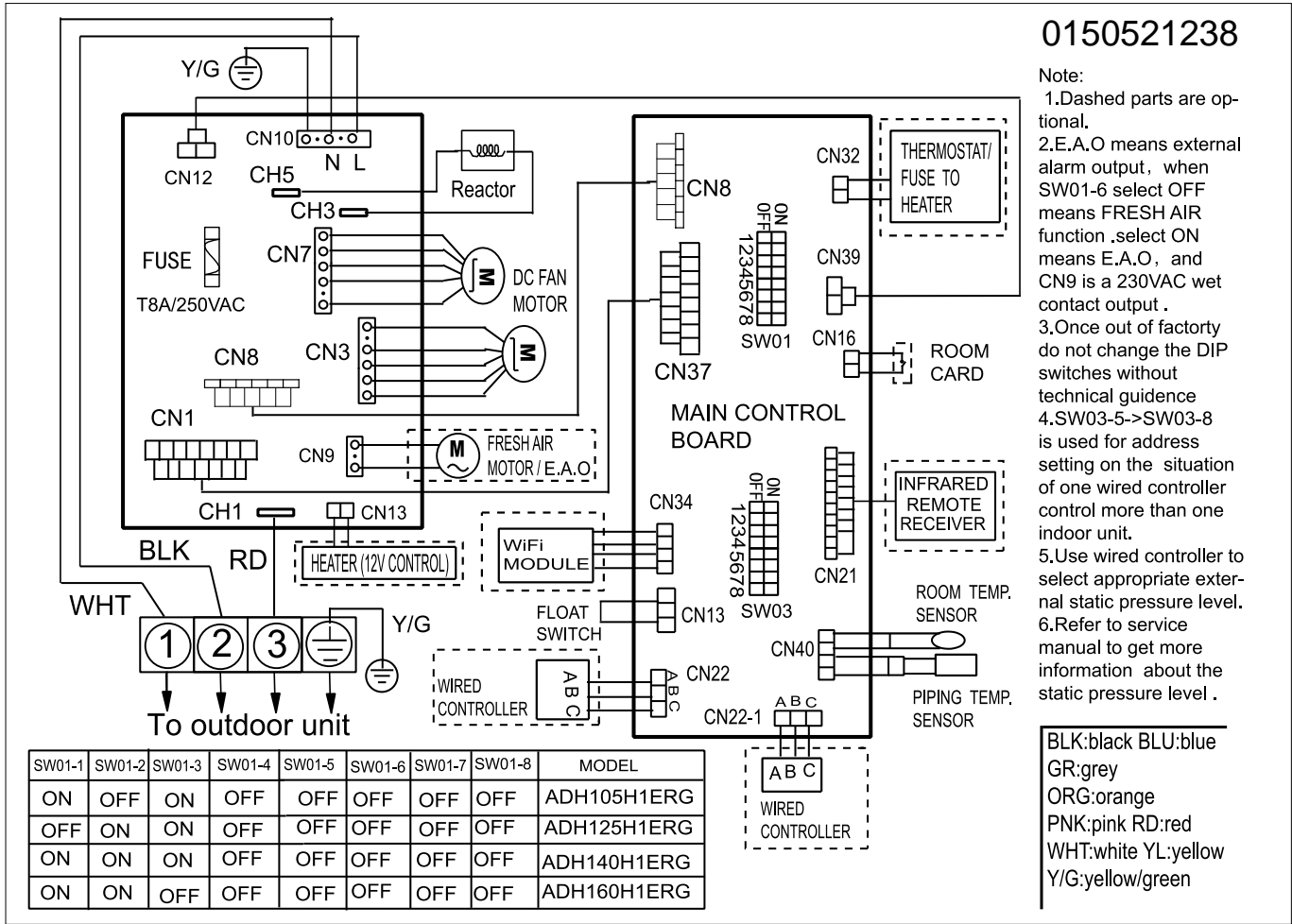

IU SETTINGS 12.5 KW - 14 KW

SW1(BM1) 1=ON 0=OFF									DESCRIPTION
Power (SW1-1 / SW1-3)			Room card	Cooling only / Heat pump	Enabling feature SMART FOLLOW				
SW1-1	SW1-2	SW1-3	SW1-4	SW1-5	SW1-6	SW1-7	SW1-8		
ON	OFF	ON	---	---	---	---	---	Power: 10.5 kW	
OFF	ON	ON	---	---	---	---	---	Power: 12.5 kW	
ON	ON	ON	---	---	---	---	---	Power: 14.0 kW	
ON	ON	OFF	---	---	---	---	---	Power: 16.0 kW	
---	---	---	OFF	---	---	---	---	* Room card with restart	
---	---	---	ON	---	---	---	---	Room card without restart	
---	---	---	---	OFF	---	---	---	Heat pump	
---	---	---	---	ON	---	---	---	Cooling-only	
---	---	---	---	---	ON	ON	OFF	High pressure (default)	

* Room card: When the contact is closed, the unit will start again in automatic mode with set point at 24°C

SW2 UNIT ADDRESS FOR WIRED CONTROLLER

Addresses for communication of multiple units with a single wired controller. You can connect up to 16 indoor units using a single wired controller. Each unit must have its respective address:

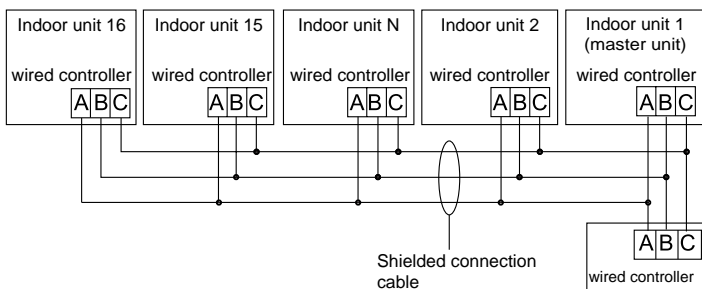

SW2	
master unit	ON OFF 1 2 3 4
slave unit 1	ON OFF 1 2 3 4
slave unit 2	ON OFF 1 2 3 4

IU CIRCUIT DIAGRAM 20 KW - 25 KW

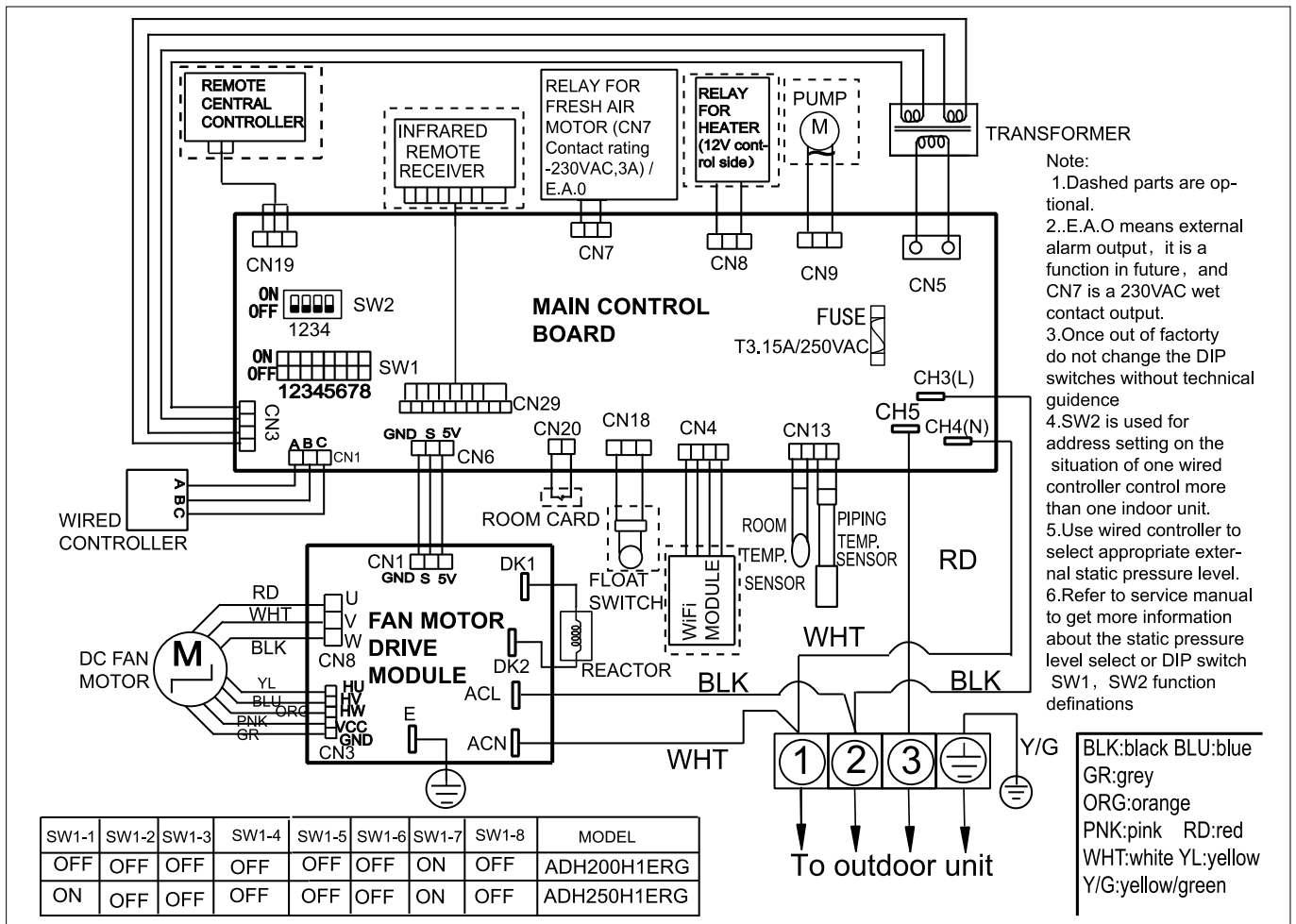

IU SETTINGS 12.5 KW - 14 KW

SW1(BM1) 1=ON 0=OFF								
SW1-1	SW1-2	SW1-3	SW1-4	SW1-5	SW1-6	SW1-7	SW1-8	MODELS
OFF	OFF	OFF	---	---	---	---	---	ADH200H1ERG
ON	OFF	OFF	---	---	---	---	---	ADH250H1ERG
---	---	---	OFF	---	---	---	---	* Room card with restart
---	---	---	ON	---	---	---	---	Room card without restart
---	---	---	---	OFF	---	---	---	Heat pump
---	---	---	---	ON	---	---	---	Cooling-only
---	---	---	---	---	OFF	ON	OFF	Default

* Room card: When the contact is closed, the unit will start again in automatic mode with set point at 24°C

Reading and modifying the static fan pressure (wired controller)

FOR READING/MODIFYING THE STATIC PRESSURE, OPERATE DIRECTLY THROUGH THE WIRED CONTROLLER (E.G. YR E-17)

1. With the controller on and without a screensaver active, press the "Fan" and "Set" keys for 5s at the same time; The static pressure icon flashes and its current value is displayed. Using the keys it is possible to modify the static pressure value. Press the SET key to confirm your modifications.
2. The unit number is displayed in the minutes field in the upper-left corner and the static pressure value in the minutes field of the timer field in the upper right. Press the TIME key to move to the unit number.
3. The unit number is displayed in decimal format between 00 and 15. The static pressure value is displayed in a decimal value between 01 and 04.
4. When modifying, press the ON/OFF key to exit the function and turn the unit on/off without confirming any changes.
5. The static pressure value is not retained when the auto restart function is not set.
6. The static pressure value of "slave" units, when connected in groups, is not modifiable.
7. The current/adjustable static pressure value of the indoor unit can be changed by the wired controller, only for certain models, from the advanced functions menu.

Prevalence setting of Ducted with remote control:

Set the mode: VENTILATION

Set the fan speed: HIGH

Quickly press HEALTH 4+n times, where "n" is the desired static pressure level

The Ducted responds with n+1 beeps, indicating the level set

NB:

Slim Ducted Low Pressure: 4 static pressure levels: 0/10/20/30

Medium Pressure: 10 static pressure levels: 25/37/50/70/90/100/110/120/130/150

High Pressure: 10 static pressure levels: 37/50/70/90/110/130/150/170/190/210

Example:

Slim Ducted Low Pressure AD35S2SS1FA

To set maximum static pressure:

- ventilation mode, high speed; quickly press HEALTH 4+4= 8 TIMES; the Ducted will respond with 4+1=5 BEEPs

SW2 UNIT ADDRESS FOR WIRED CONTROLLER

Addresses for communication of multiple units with a single wired controller. You can connect up to 16 indoor units using a single wired controller. Each unit must have its respective address:

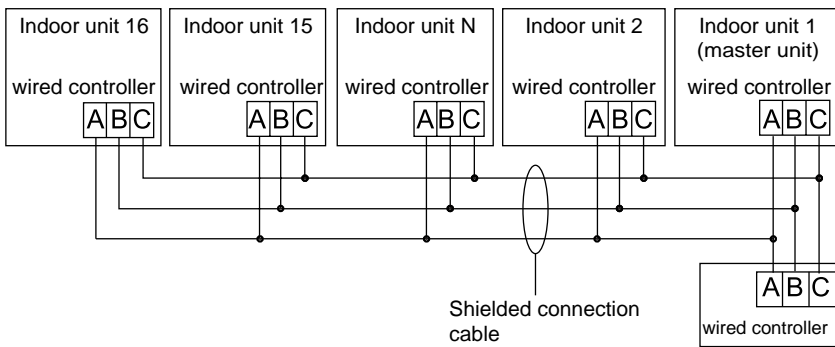

SW2	
master unit	ON OFF
slave unit 1	ON OFF
slave unit 2	ON OFF

Indoor-outdoor units

AH1-LCAC1

AH1-RAC1

INDOOR UNIT MODEL	AH1-LCAC1	AH1-RAC1
Power Supply (Ph/V/Hz)	1 Phase / 220~240V / 50/60Hz	1 Phase / 220~240V / 50/60Hz
Dimension (W/D/H) mm	206x52,5x110	206x52,5x110
Package Dimension (W/D/H) mm	240/80/120	240/80/120
Weight (KG)	0,4	0,4

COMPATIBILITY

	MODEL	AH1-LCAC1	AH1-RAC1
	1U25S2SM1FA-2		•
	1U35S2SM1FA-2		•
	1U42S2SM1FA		•
	1U50S2SJ2FA-2		•
	1U71S2ST1FA	•	
	1U105S2SS1FA	•	
	1U105S2SS2FA	•	
	1U105S2SS1FB	•	
	1U125S2SN2FA	•	
	1U125S2SN2FB	•	
	1U140S2SN1FA	•	
	1U140S2SN1FB	•	
	1U140S2SP2FB	•	
	1U140S2SP2FA	•	
	1U160S2SP1FB	•	

SYSTEM WIRING DIAGRAM

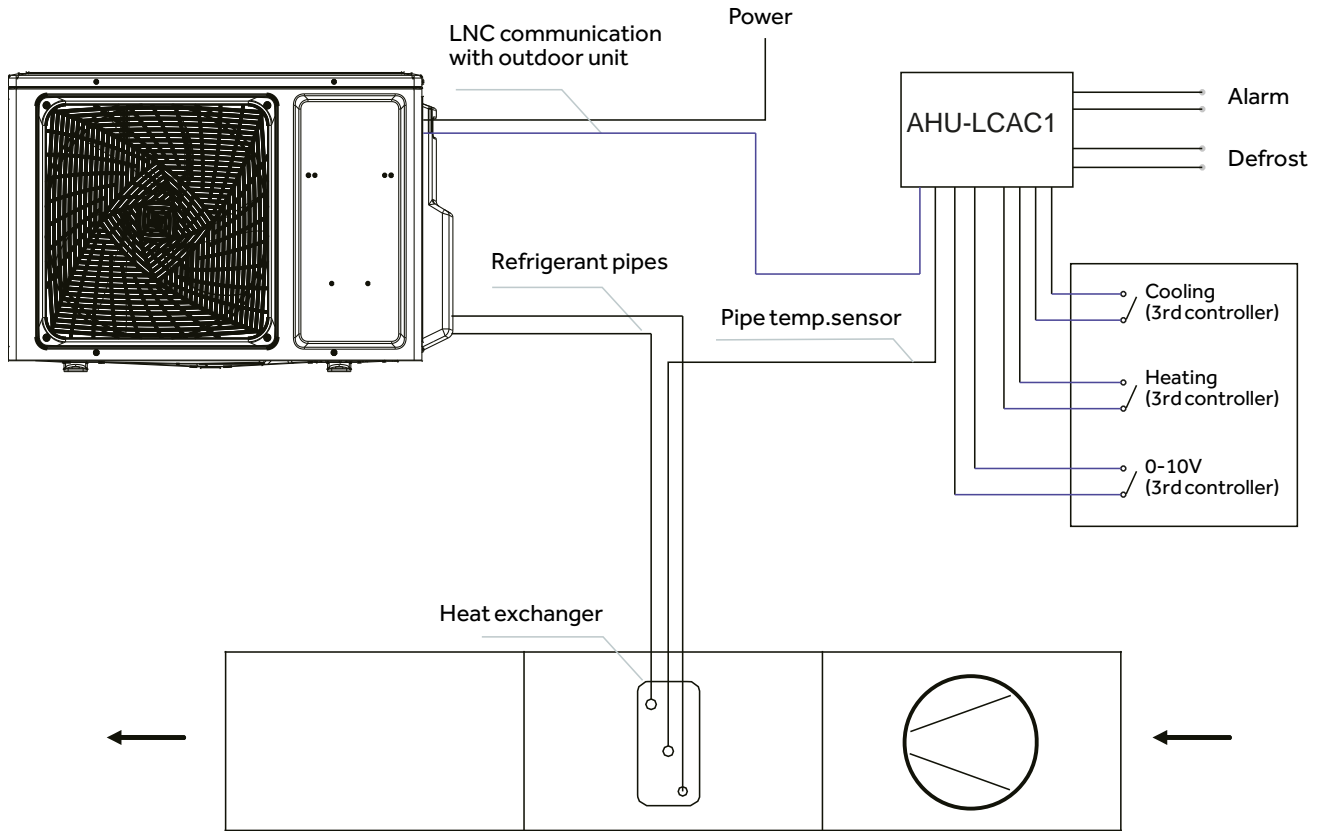

AHU UNIT DIAGRAM

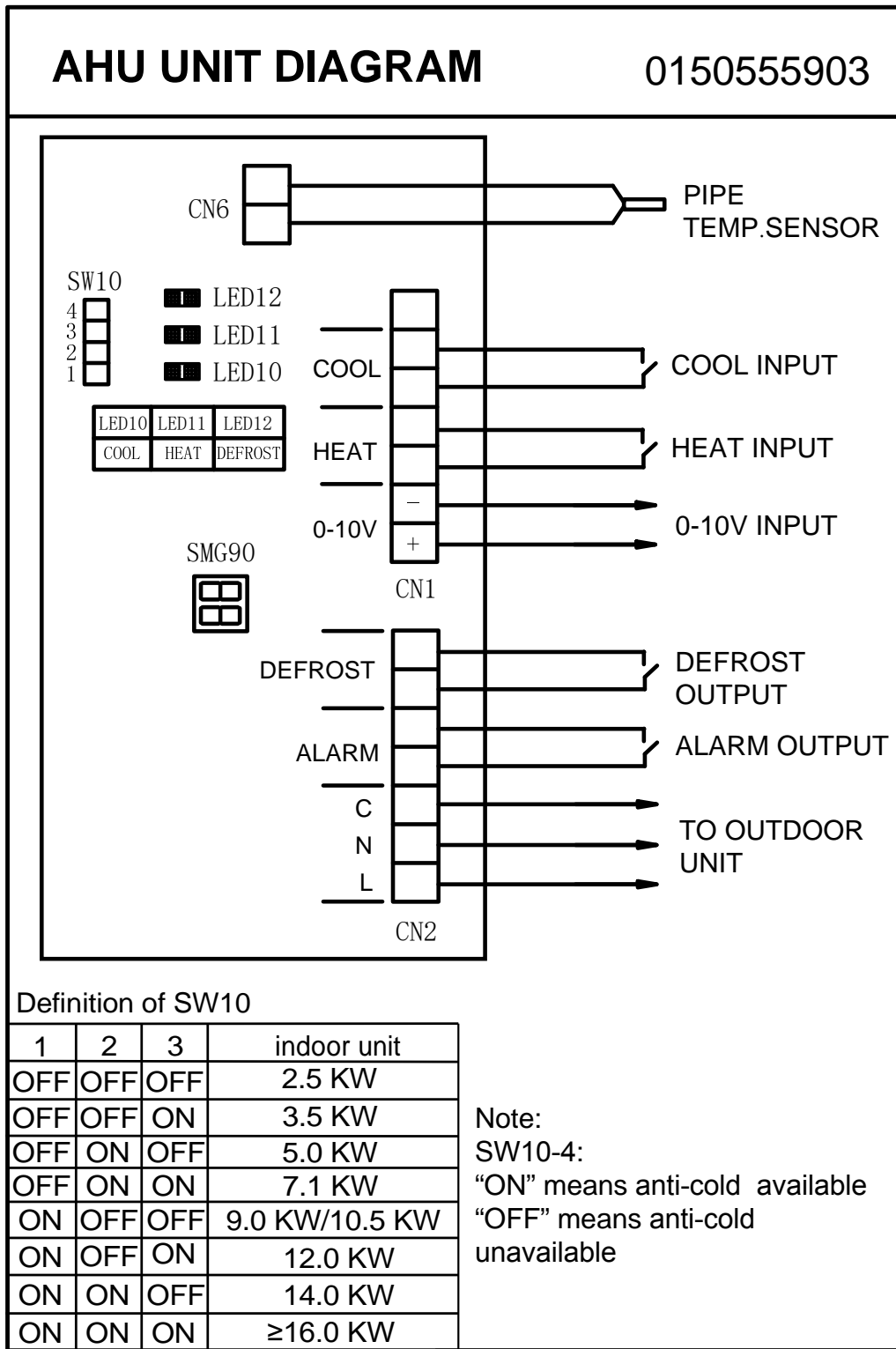

Indoor-outdoor units
AP71DFMHRA - 1U71WEMFRA (7.1 kW)

INDOOR UNIT MODEL			AP71DFMHRA
OUTDOOR UNIT MODEL			1U71WEMFRA
Indoor unit technical data			
Treated air volume	H	m ³ /h	1510
Net dimensions	WxDxH	mm	408x435x1810
Net / gross weight		kg	26,5/34,5
Outdoor unit technical data			
Liquid pipe Ø		mm (inch)	6,35 (1/4)
Gas pipe Ø		mm (inch)	12,7 (1/2)
Standard pipe length without refrigerant charge		m	5
Maximum pipe length		m	20
Minimum pipe length		m	5
Power Supply		Ph / V / Hz	1 / 220-240 / 50
Net / gross weight		kg	43,5 / 47,5
Additional ref. charge over std length		g/m	20

DIAGNOSTICS 7.1 KW

For diagnostics, see **pages 28 - 29**.

See the list of alarms on **page 14**.

IU CIRCUIT DIAGRAM 7.1 KW

INDOOR WIRING DIAGRAM 0010593706X

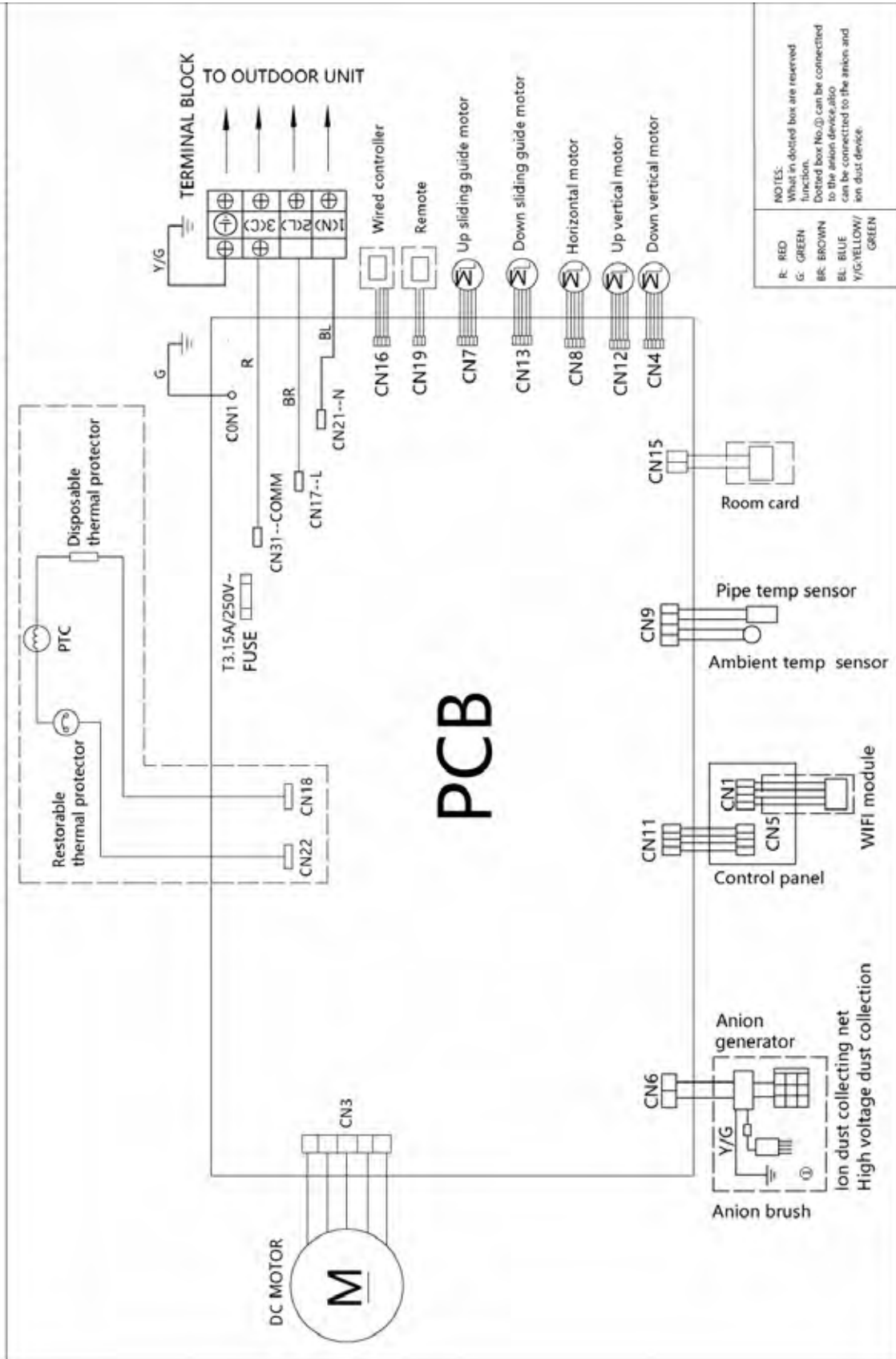

INDOOR UNIT SETTINGS 7.1 KW

Selecting the frequency of remote control A or B (SW2-1):

Switch 1 selects the working frequency of the remote control of the indoor wall unit, from "A" to "B".

Set the same frequency on the remote control.

OFF operating frequency "A"

ON operating frequency "B"

After turning to the automation mode, the running mode can be switched between cooling mode, fan mode and heating mode according to the change of the indoor ambient temperature. But the automatic conversion between cooling mode and heating mode must be conducted after 15 minutes.

Automatic: The air conditioner unit select the fan speed (High, Medium, Low) automatically according to the change of the indoor ambient temperature.

Power Saving Operation

Automatic adjusting with the environmental temperature, running with power saving.

1. Available operation mode: Heating, Cooling, Dehumidifying
2. Control features: after the power saving is set, the host machine will judge the temperature difference between set temperature and indoor room temperature and unit running time. The unit will adjust the set temperature according to the judgement. After the power saving is set, the host machine will automatically adjust the setting temperature, and automatically control the switch of the compressor, which may be inconsistent with the user's setting. The power saving function is more effective after the air conditioning has been running for a long time (more than 2 hours). After cancelling the power saving function, the unit will restore the original setting temperature and fan speed.

Model selection jumper J1 status: ON (large model)/OFF (small model) ON means keep; OFF means cut.

J1	ON	OFF
PCB Series	72	50

UNIT MODEL	J1
AP71DFMHRA	ON

Indoor-outdoor units

AP105S2SK1FA(H) - 1U105S2SS2FA (10.5 kW)

AP140S2SK1FA(H) - 1U140S2SN1FA (14 kW)

AP140S2SK1FA(H) - 1U140S2SN1FB (14 kW)

AP160S2SK1FA(H) - 1U160S2SP1FB (16 kW)

INDOOR UNIT MODEL			AP105S2SK1FA(H)	AP140S2SK1FA(H)	AP140S2SK1FA(H)	AP160S2SK1FA(H)
OUTDOOR UNIT MODEL			1U105S2SS2FA	1U140S2SN1FA	1U140S2SN1FB	1U160S2SP1FB
Indoor unit technical data						
Treated air volume	H	m ³ /h	1580/1450/1350	1850/1500/1350	1850/1500/1350	1850/1500/1350
Net dimensions	WxDxH	mm	600x350x1850	600x350x1850	600x350x1850	600x350x1850
Net / gross weight		kg	50,0 / 61,0	50,0 / 61,0	50,0 / 61,0	50,0 / 61,0
Outdoor unit technical data						
Liquid pipe Ø		mm (inch)	9,52 (3/8)	9,52 (3/8)	9,52 (3/8)	9,52 (3/8)
Gas pipe Ø		mm (inch)	15,88 (5/8)	15,88 (5/8)	15,88 (5/8)	19,05 (3/4)
Standard pipe length without refrigerant charge		m	30	30	30	30
Maximum pipe length		m	50	70	70	70
Minimum pipe length		m	5	5	5	5
Power Supply		Ph / V / Hz	1/220~240/50/60	1/220~240/50/60	3 / 380~415/ 50/60	3 / 380~415/ 50/60
Net / gross weight		kg	60,0 / 65,0	101 / 116	84,0 / 89,0	85,0 / 90,0
Additional ref. charge over std length		g/m	45	45	45	60

DIAGNOSTICS 10.5 KW - 14 KW - 16KW

For diagnostics, see **pages 32 - 33**.

See the list of alarms on **page 14**.

PCB 0151800697

AP105S2SK1FA(H) AP140S2SK1FA(H) AP160S2SK1FA(H)

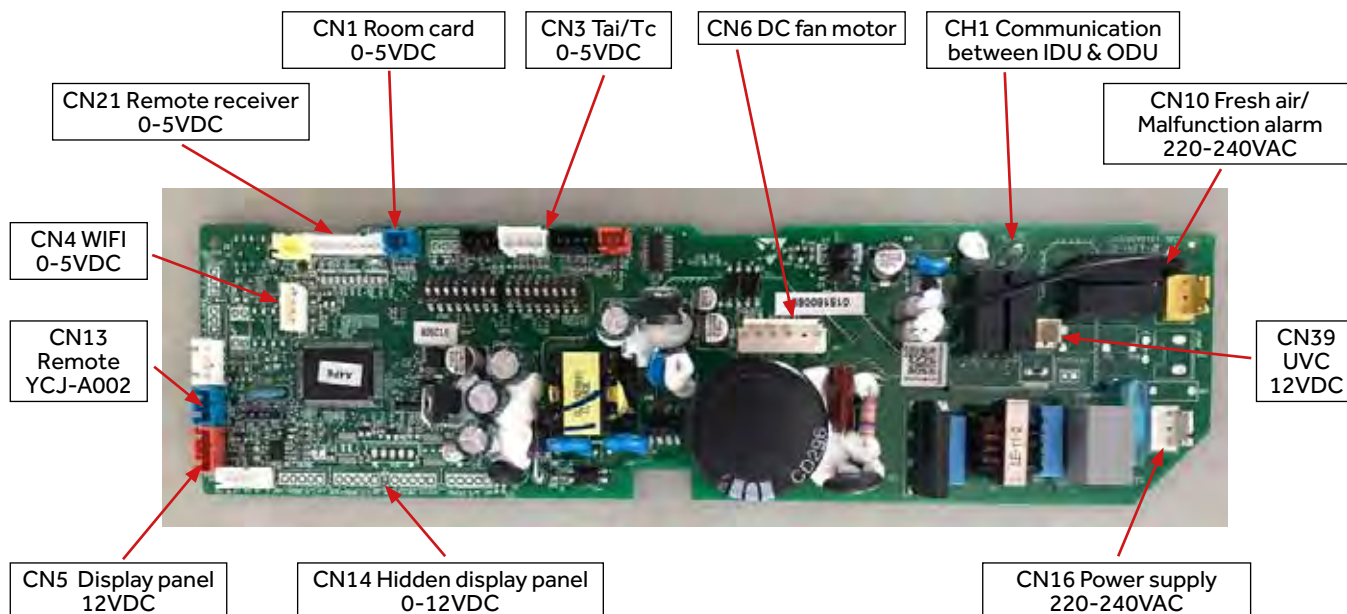

IU SETTINGS 14 KW - 16 KW

AP105S2SK1FA(H) AP140S2SK1FA(H) AP160S2SK1FA(H) PCB CODE:0151800697

BM1-1	BM1-2	BM1-3	BM1-4	BM1-5	BM1-6	BM1-7	BM1-8	DESCRIPTION
ON	OFF	ON	---	---	---	OFF	---	AP105S2SK1FA(H)
ON	ON	ON	---	---	---	OFF	---	AP140S2SK1FA(H)
ON	ON	ON	---	---	---	ON	---	AP160S2SK1FA(H)
---	---	---	ON	---	---	---	---	Room card function valid
---	---	---	OFF	---	---	---	---	Room card function invalid (default)
---	---	---	---	ON	---	---	---	Cooling only
---	---	---	---	OFF	---	---	---	Heat pump (default)
---	---	---	---	---	ON	---	---	Malfunction alarm & filter reminding
---	---	---	---	---	OFF	---	---	Fresh air (default)
---	---	---	---	---	---	---	ON	Non-American area (default)
---	---	---	---	---	---	---	OFF	American area

BM3-1	BM3-2	BM3-3	BM3-4	BM3-5	BM3-6	BM3-7	BM3-8	DESCRIPTION
OFF	---	---	---	---	---	---	---	Reserved
---	OFF	---	---	---	---	---	---	Reserved
---	---	OFF	---	---	---	---	---	Reserved
---	---	---	OFF	---	---	---	---	Reserved
---	---	---	---	OFF	OFF	OFF	OFF	Address of Wire Controlled Indoor Unit

MONO SPLIT & MULTI SPLIT UNITS

Jade Supermatch	68
Expert Black/White	71
Flexi Plus Black/White	74
Pearl Premium	77
Revive Plus	81
Console	85
1-Way Cassette	89
Cassette 620	81
Round Flow Cassette	93
Ceiling Floor	97
Slim Duct Low Pressure	101
Ducted Medium Pressure	105

OUTDOOR UNIT R32 MULTISPLIT		1:2		1:3		1:4		1:5			3S	
		2U50S2SM1FA	2U50S2SM1FA-3	3U55S2SR5FA	3U70S2SR5FA	4U75S2SR5FA	4U85S2SR5FA	5U90S2S55FA	5U105S2S55FA	5U125S2SN1FA	3U55S2WR1FA	4U70S2WR1FA
INDOOR UNIT R32	kW	4,0 kW	5,0 kW	5,5 kW	7,0 kW	7,5 kW	8,5 kW	9,0 kW	10,5 kW	12,5 kW	5,5 kW	7,0 kW
JADE	2,5	•	•	•	•	•	•	•	•	•	•	•
	3,5	•	•	•	•	•	•	•	•	•	•	•
	5,0			•	•	•	•	•	•	•	•	•
EXPERT	2,0	•	•	•	•	•	•	•	•	•	•	•
	2,5	•	•	•	•	•	•	•	•	•	•	•
	3,5	•	•	•	•	•	•	•	•	•	•	•
	5,0			•	•	•	•	•	•	•	•	•
FLEXIS PLUS	7,1				•	•	•	•	•	•		•
	2,0	•	•	•	•	•	•	•	•	•	•	•
	2,5	•	•	•	•	•	•	•	•	•	•	•
	3,5	•	•	•	•	•	•	•	•	•	•	•
PEARL PREMIUM	5,0			•	•	•	•	•	•	•	•	•
	6,8				•	•	•	•	•	•		•
	2,5	•	•	•	•	•	•	•	•	•	•	•
	3,5	•	•	•	•	•	•	•	•	•	•	•
REVIVE PLUS	5,0			•	•	•	•	•	•	•	•	•
	6,8				•	•	•	•	•	•		•
	2,5	•	•	•	•	•	•	•	•	•	•	•
	3,5	•	•	•	•	•	•	•	•	•	•	•
CONSOLE	4,2			•	•	•	•	•	•	•	•	•
	5,0			•	•	•	•	•	•	•	•	•
	2,5			•	•	•	•	•	•	•	•	•
	3,5			•	•	•	•	•	•	•	•	•
1 WAY CASSETTE	5,0			•	•	•	•	•	•	•	•	•
	7,1				•	•	•	•	•	•		•
	2,5			•	•	•	•	•	•	•	•	•
	3,5			•	•	•	•	•	•	•	•	•
CASSETTE 620	5,0			•	•	•	•	•	•	•	•	•
	7,1				•	•	•	•	•	•		•
	2,5			•	•	•	•	•	•	•	•	•
CASSETTE ROUND FLOW	3,5				•	•	•	•	•	•	•	•
	5,0			•	•	•	•	•	•	•	•	•
	7,1				•	•	•	•	•	•		•
	2,5			•	•	•	•	•	•	•	•	•
CEILING FLOOR	3,5				•	•	•	•	•	•	•	•
	5,0			•	•	•	•	•	•	•	•	•
	7,1				•	•	•	•	•	•		•
	2,5			•	•	•	•	•	•	•	•	•
SLIM DUCT LOW PRESSURE	3,5			•	•	•	•	•	•	•	•	•
	5,0			•	•	•	•	•	•	•	•	•
	7,1				•	•	•	•	•	•		•
	3,5			•	•	•	•	•	•	•	•	•
DUCTED MEDIUM PRESSURE	5,0			•	•	•	•	•	•	•	•	•
	7,1				•	•	•	•	•	•		•
REVIVE PLUS	100l										•	•
	200l										•	•

The expressed kW/Btu is for cooling classification. For exact values, see the technical data tables of the individual models.

OUTDOOR UNITS MULTISPLIT R32									MULTISPLIT 3S	
4,0 kW	5,0 kW	5,5 kW	7,0 kW	7,5 kW	8,5 kW	9,0 kW	10,5 kW	12,5 kW	5,5 kW	7,0 kW
1:2		1:3		1:4		1:5			1:3	1:4
									NEW 	NEW
Self-clean										

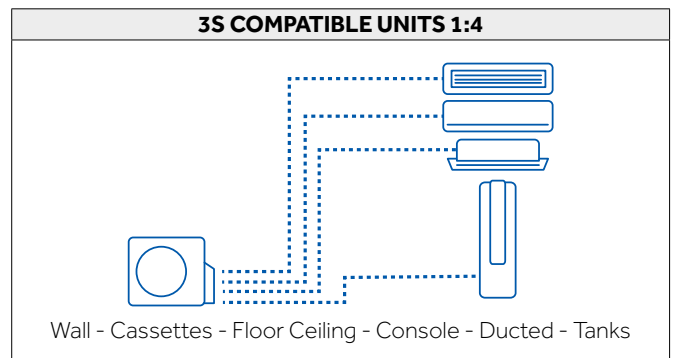
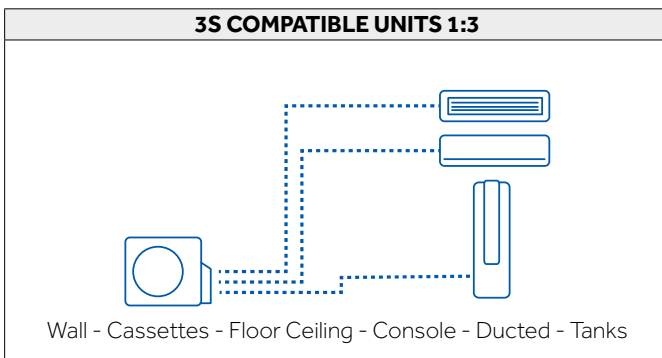
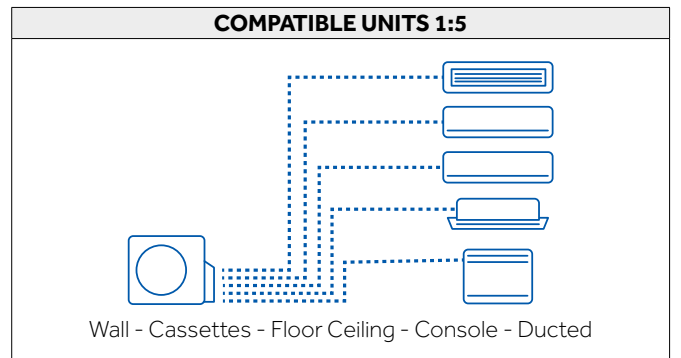
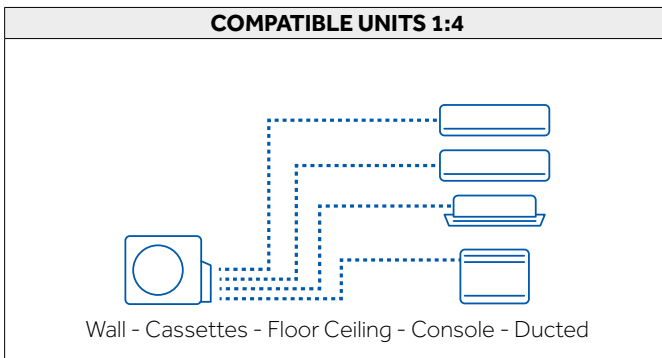
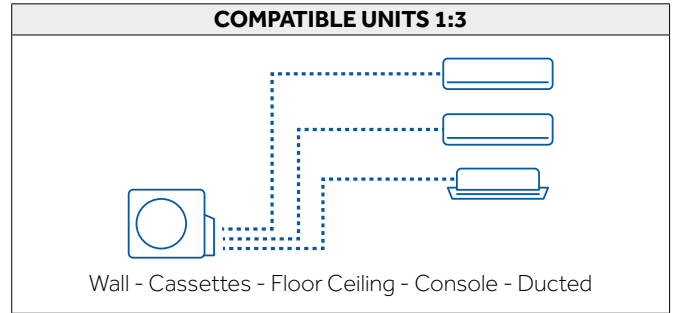
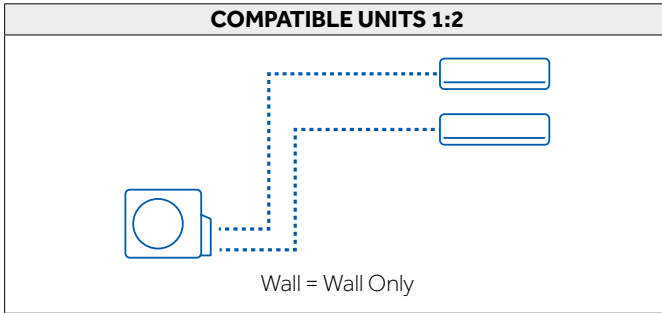

The expressed kW/Btu is for cooling classification. For exact values, see the technical data tables of the individual models.

Indoor-outdoor units

AS25S2SJ1FA-3 - 1U25MECFRA-3 (2,5 kW)

AS35S2SJ1FA-3 - 1U35MECFRA-3 (3,5 kW)

INDOOR UNIT MODEL			AS25S2SJ1FA-3	AS35S2SJ1FA-3
OUTDOOR UNIT MODEL			1U25MECFRA-3	1U35MECFRA-3
Indoor unit technical data				
Treated air volume	H	m ³ /h	550	600
Net dimensions	WxDxH	mm	923x215x320	923x215x320
Net / gross weight		kg	12,0 / 15,2	12,0 / 15,2
Outdoor unit technical data				
Liquid pipe Ø		mm (inch)	6,35 (1/4)	6,35 (1/4)
Gas pipe Ø		mm (inch)	15,88 (5/8)	15,88 (5/8)
Standard pipe length without refrigerant charge		m	7	7
Maximum pipe length		m	20	20
Minimum pipe length		m	5	5
Power Supply		Ph / V / Hz	1 / 220~240 / 50	1 / 220~240 / 50
Net / gross weight		kg	29,8 / 33,6	29,8 / 33,6
Additional ref. charge over std length		g/m	20	20

DIAGNOSTICS 2.5 KW - 3.5 KW

For diagnostics, see **pages 30 - 31**.

See the list of alarms on **page 13**.

INDOOR UNIT CIRCUIT DIAGRAM 2.5 KW - 3.5 KW

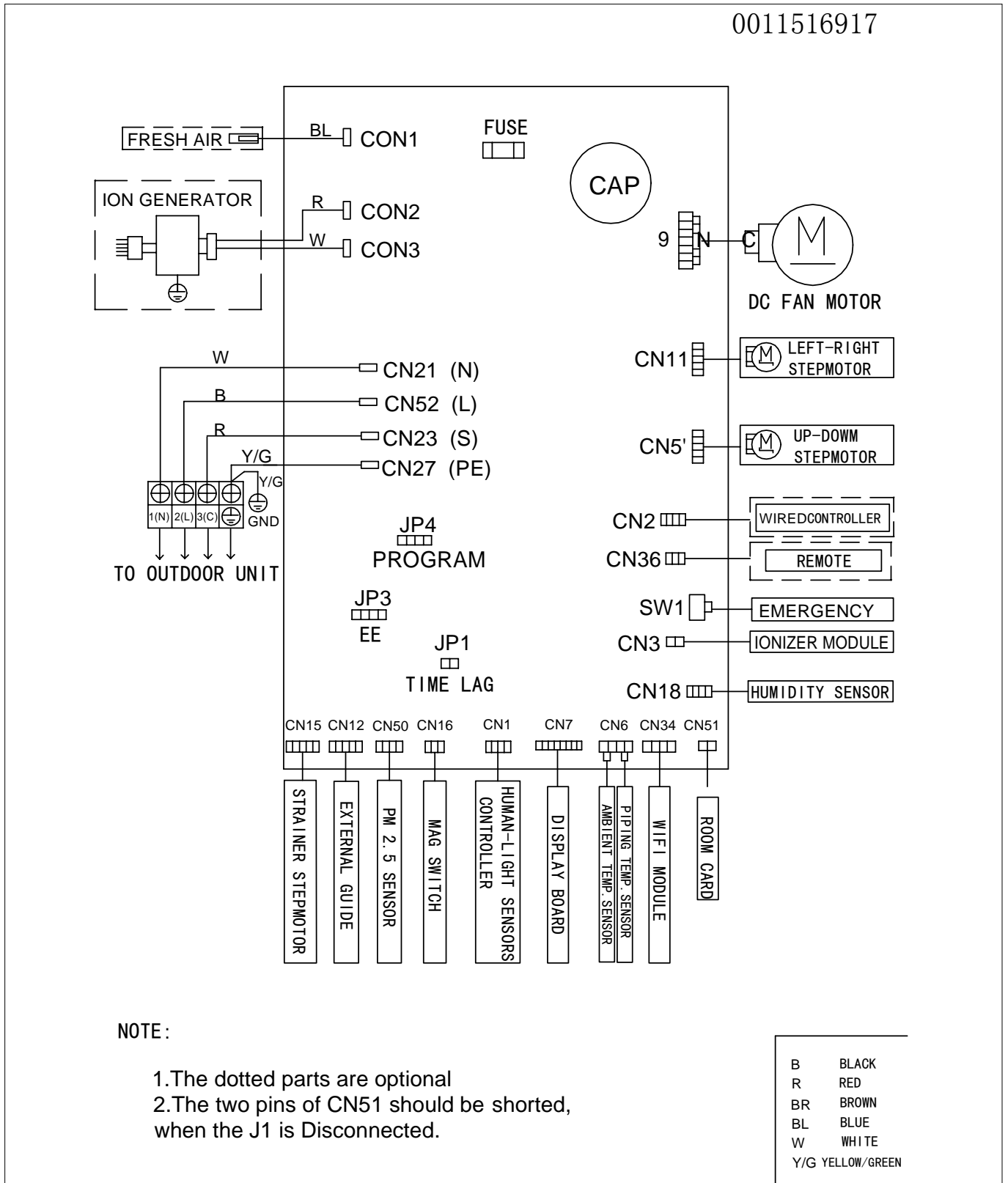

INDOOR UNIT SETTING:

Selecting the frequency of remote control A or B:

Switch **J2** selects the working frequency of the remote control of the indoor wall unit, from "A" to "B".

Set the same frequency on the remote control.

OFF operating frequency "A"

ON operating frequency "B"

Selecting the room-card (indoor unit activation board):

Using switch **J1**, you can select the operating mode of the room-card (CN51), which is a clean contact where components (e.g. window contact) can be applied, so as to be able to manage the switching on and/or off of the indoor units in the system:

OFF With open contact the unit stops and with closed contact the unit starts (even if it was previously turned off) in the last mode used.
With outdoor contact open, the local controller can turn the unit on/off.

ON With open contact the unit stops, and with closed contact the unit is ready to start (it is turned on by remote control).
With outdoor contact open, the controller cannot control the unit.

Selecting the indoor unit power (J5 - J6):

Using jumpers 5 and 6 you can select the power of the indoor unit:

	3.5 kW	2.5 kW
J5	OFF	OFF
J6	ON	OFF

Important: Cut the jumpers **J3**, **J4** on board depending on the split on which the electronic board will be installed. (already cut in factory depending on the model).

This procedure is essential in order for the main board to communicate correctly with the receiving display/board.

	JADE
J3	ON
J4	OFF

Selecting the ambient temperature/set-point on the display: To switch the display between real temperature and ambient set-point, press the LIGHT key of the remote control 10 times. The indoor unit will respond with: 2 BEEP sounds to display ambient temperature, 4 BEEP sounds to display set-point temperature.

Activating/deactivating power-saving feature of the fan motor in cooling mode:

Directing the remote control to the indoor unit:

1. Press the "AUTO" (or "SMART") key
2. Press the "HEALTH" key 6 times

The indoor unit will respond with 2 "BEEP" sounds and the eco function will be disabled.

The fan will always be in operation, even if the set ambient temperature is reached.

By repeating steps 1 and 2, the indoor unit will respond with 4 "BEEP" sounds and the eco function will be reactivated.

The fan will be stopped when the set ambient temperature is reached.

Indoor-outdoor units

AS25XCAHRA (WHITE) / AS25XCAHRA-MB (BLACK) - 1U25S2SM1FA-2 (2,5 kW)

AS35XCAHRA (WHITE) / AS35XCAHRA-MB (BLACK) - 1U35S2SM1FA-2 (3,5 kW)

AS50XCAHRA (WHITE) / AS50XCAHRA-MB (BLACK) - 1U50S2SJ2FA-2 (5,0 kW)

AS71XCAHRA (WHITE) / AS71XCAHRA-MB (BLACK) - 1U71S2ST1FA (7,1 kW)

INDOOR UNIT WHITE			AS25XCAHRA	AS35XCAHRA	AS50XCAHRA	AS71XCAHRA
INDOOR UNIT BLACK			AS25XCAHRA-MB	AS35XCAHRA-MB	AS50XCAHRA-MB	AS71XCAHRA-MB
OUTDOOR UNIT MODEL			1U25S2SM1FA-2	1U35S2SM1FA-2	1U50S2SJ2FA-2	1U71S2ST1FA
Indoor unit technical data						
Treated air volume	H	m ³ /h	730	800	880	920
Net dimensions	WxDxH	mm	895x236x313	895x236x313	895x236x313	11,3/14,013
Net / gross weight		kg	11,3 / 14,0	11,3 / 14,0	11,6 / 14,2	12,4 / 14,8
Outdoor unit technical data						
Liquid pipe Ø		mm (inch)	6,35 (1/4)	6,35 (1/4)	6,35 (1/4)	9,52 (3/8)
Gas pipe Ø		mm (inch)	9,52 (3/8)	9,52 (3/8)	12,70 (1/2)	15,88 (5/8)
Standard pipe length without refrigerant charge		m	7	7	7	7
Maximum pipe length		m	20	20	25	50
Minimum pipe length		m	5	5	5	5
Power Supply		Ph / V / Hz	1 / 220-240 / 50	1 / 220-240 / 50	1 / 220-240 / 50	1 / 220-240 / 50
Net / gross weight		kg	27,6 / 30,4	30 / 32,9	35,7 / 38,5	44 / 48
Additional ref. charge over std length		g/m	20	20	20	20

DIAGNOSTICS 2.5 KW – 3.5 KW – 5.0 KW – 7.1 KW

For diagnostics, see **pages 30 - 31**.

See the list of alarms on **page 13**.

IU CIRCUIT DIAGRAM 2.5 KW - 3.5 KW - 5.0 KW - 7.1 KW

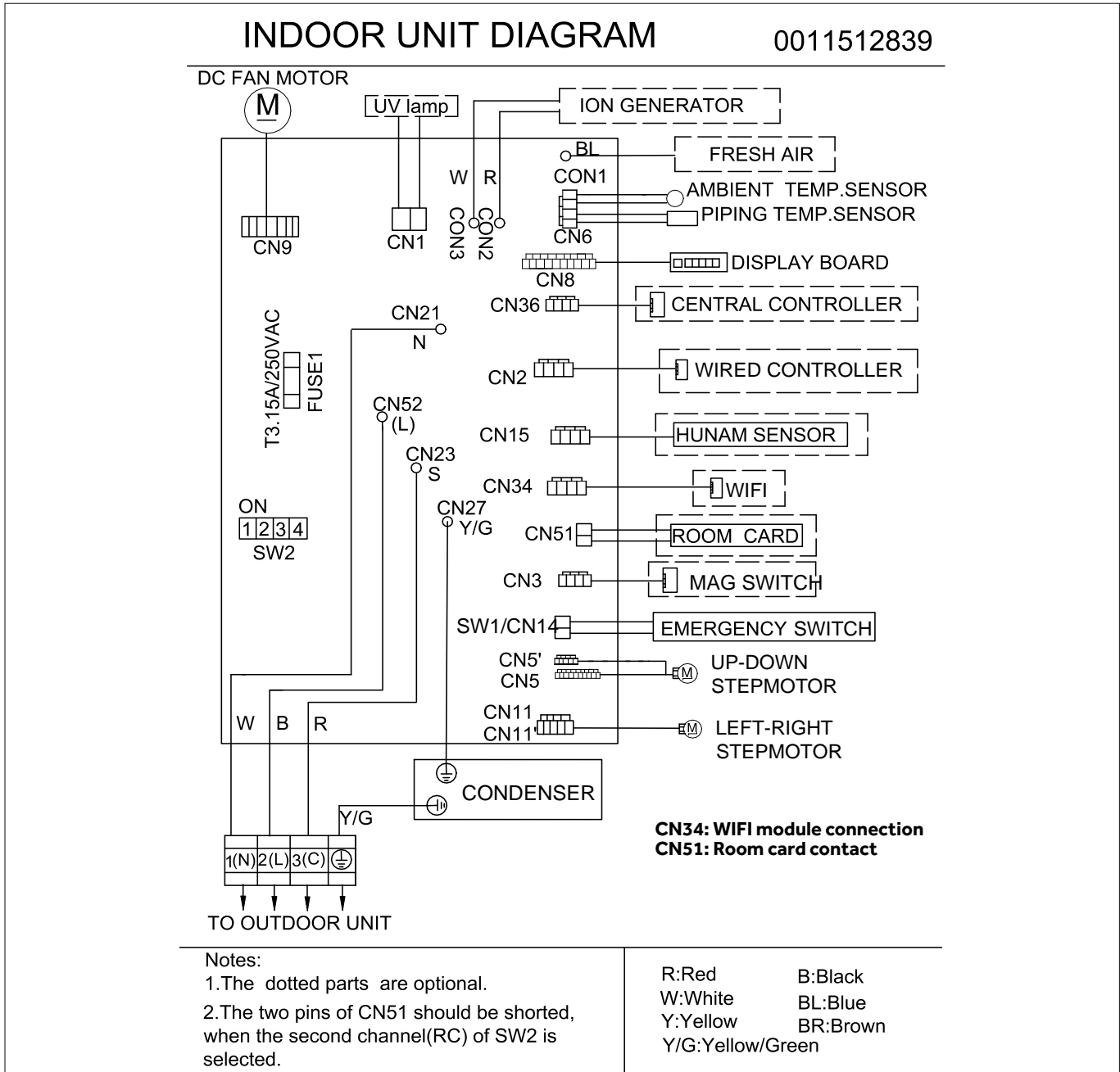

INDOOR UNIT SETTING:

Selecting the frequency of remote control A or B (SW2-1):

Switch 1 selects the working frequency of the remote control of the indoor wall unit, from "A" to "B".
Set the same frequency on the remote control.

- OFF** operating frequency "A"
- ON** operating frequency "B"

Selecting the room-card (indoor unit activation board) (SW2-2):

Using switch 2, you can select the operating mode of the room-card (CN51), which is a clean contact where components (e.g. window contact) can be applied, so as to be able to manage the switching on and/or off of the indoor units in the system:

- OFF** With open contact the unit stops and with closed contact the unit starts (even if it was previously turned off) in the last mode used.
With outdoor contact open, the local controller can turn the unit on/off.
- ON** With open contact the unit stops, and with closed contact the unit is ready to start (it is turned on by remote control).
With outdoor contact open, the controller cannot control the unit.

Selecting the indoor unit power (SW2-3) and (SW2-4):

Using switches 3 and 4 you can select the power of the indoor unit:

	2.5 kW	3.5 kW	5.0 kW	7.1 kW
SW2-3	OFF	OFF	ON	-
SW2-4	OFF	ON	OFF	-

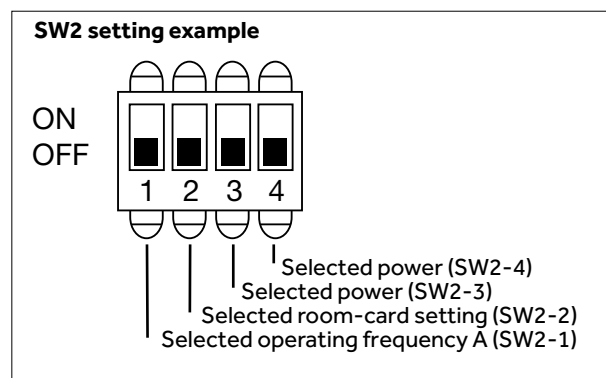

Important: Cut the jumpers **J1, J2** on board depending on the split on which the electronic board will be installed. (already cut in factory depending on the model).

This procedure is essential in order for the main board to communicate correctly with the receiving display/board.

	EXPERT
J1	ON
J2	OFF

Selecting the ambient temperature/set-point on the display: To switch the display between real temperature and ambient set-point, press the LIGHT key of the remote control 10 times. The indoor unit will respond with: 2 BEEP sounds to display ambient temperature, 4 BEEP sounds to display set-point temperature.

Activating/deactivating power-saving feature of the fan motor in cooling mode:

Directing the remote control to the indoor unit:

1. Press the "AUTO" (or "SMART") key
2. Press the "HEALTH" key 6 times

The indoor unit will respond with 2 "BEEP" sounds and the eco function will be disabled.
The fan will always be in operation, even if the set ambient temperature is reached.

By repeating steps 1 and 2, the indoor unit will respond with 4 "BEEP" sounds and the eco function will be reactivated.
The fan will be stopped when the set ambient temperature is reached.

Indoor-outdoor units

AS25S2SF1FA-MW3 (WHITE) / AS25S2SF1FA-MB3 (BLACK) - 1U25S2SM1FA-2 (STANDARD) / 1U25MEHFRA-1 (NORDIC) (2,5 kW)

AS35S2SF1FA-MW3 (WHITE) / AS35S2SF1FA-MB3 (BLACK) - 1U35S2SM1FA-2 (STANDARD) / 1U35MEHFRA-1 (NORDIC) (3,5 kW)

AS50XCAHRA (WHITE) / AS50XCAHRA-MB (BLACK) - 1U50S2SJ2FA-2 (STANDARD) / 1U50KEFFRA-1 (NORDIC) (5,0 kW)

AS71S2SF1FA-MW3 (WHITE) / AS71S2SF1FA-MB3 (BLACK) - 1U71S2ST1FA (STANDARD) (7,1 kW)

INDOOR UNIT WHITE	AS25S2SF1FA-MW3	AS35S2SF1FA-MW3	AS50XCAHRA	AS71S2SF1FA-MW3
INDOOR UNIT BLACK	AS25S2SF1FA-MB3	AS35S2SF1FA-MB3	AS50XCAHRA-MB	AS71S2SF1FA-MB3
OUTDOOR UNIT STANDARD	1U25S2SM1FA-2	1U35S2SM1FA-2	1U50S2SJ2FA-2	1U71S2ST1FA
OUTDOOR UNIT NORDIC	1U25MEHFRA-1	1U35MEHFRA-1	1U50KEFFRA-1	-

Indoor unit technical data						
Treated air volume	H	m ³ /h	600	650	900	1100
Net dimensions	WxDxH	mm	856x197x300	856x197x300	999x225x323	1115x235x343
Net / gross weight		kg	9,5 / 12,0	9,5 / 12,0	12,0 / 15,0	15,2 / 18,2
Outdoor unit technical data						
Liquid pipe Ø		mm (inch)	6,35 (1/4)	6,35 (1/4)	6,35 (1/4)	9,52 (3/8)
Gas pipe Ø		mm (inch)	9,52 (3/8)	9,52 (3/8)	12,70 (1/2)	15,88 (5/8)
Standard pipe length without refrigerant charge		m	7	7	7	7
Maximum pipe length		m	20	20	25	50
Minimum pipe length		m	5	5	5	5
Power Supply		Ph / V / Hz	1 / 220~240 / 50	1 / 220~240 / 50	1 / 220~240 / 50	1 / 220~240 / 50
Net / gross weight		kg	27,6 / 30,4	30 / 32,9	37,8 / 40,5	45,0 / 50,0
Additional ref. charge over std length		g/m	20	20	20	45

DIAGNOSTICS 2.5 KW – 3.5 KW – 5.0 KW – 7.1 KW

For diagnostics, see **pages 30 - 31**.

See the list of alarms on **page 13**.

IU CIRCUIT DIAGRAM 2.5 KW - 3.5 KW - 5.0 KW - 7.1 KW

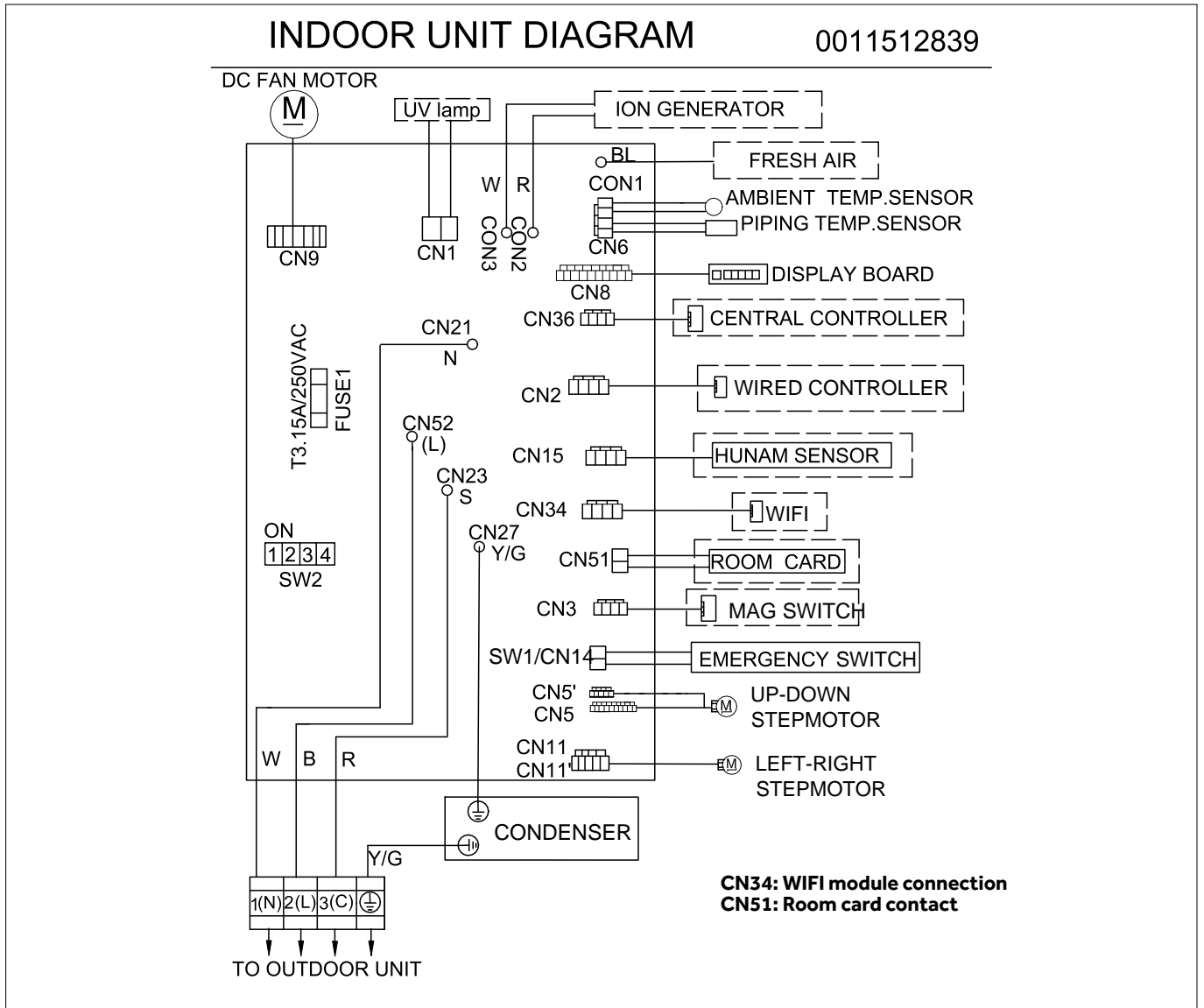

INDOOR UNIT SETTING:

Selecting the frequency of remote control A or B (SW2-1):

Switch 1 selects the working frequency of the remote control of the indoor wall unit, from "A" to "B".
Set the same frequency on the remote control.

- OFF** operating frequency "A"
- ON** operating frequency "B"

Selecting the room-card (indoor unit activation board) (SW2-2):

Using switch 2, you can select the operating mode of the room-card (CN51), which is a clean contact where components (e.g. window contact) can be applied, so as to be able to manage the switching on and/or off of the indoor units in the system:

- OFF** With open contact the unit stops and with closed contact the unit starts (even if it was previously turned off) in the last mode used.
With outdoor contact open, the local controller can turn the unit on/off.
- ON** With open contact the unit stops, and with closed contact the unit is ready to start (it is turned on by remote control).
With outdoor contact open, the controller cannot control the unit.

Selecting the indoor unit power (SW2-3) and (SW2-4):

Using switches 3 and 4 you can select the power of the indoor unit:

	2.0 kW	2.5 kW	3.5 kW	5.0 kW	7.1 kW
SW2-3	OFF	OFF	OFF	OFF	OFF
SW2-4	OFF	OFF	ON	OFF	OFF

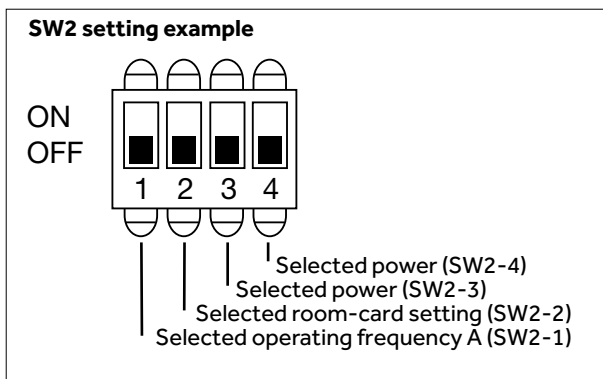

Important: Cut the jumpers **J1**, **J2** on board depending on the split on which the electronic board will be installed. (already cut in factory depending on the model).

This procedure is essential in order for the main board to communicate correctly with the receiving display/board.

	FLEXIS
J1	OFF
J2	OFF

Selecting the ambient temperature/set-point on the display: To switch the display between real temperature and ambient set-point, press the LIGHT key of the remote control 10 times. The indoor unit will respond with: 2 BEEP sounds to display ambient temperature, 4 BEEP sounds to display set-point temperature.

Activating/deactivating power-saving feature of the fan motor in cooling mode:

Directing the remote control to the indoor unit:

1. Press the "AUTO" (or "SMART") key
2. Press the "HEALTH" key 6 times

The indoor unit will respond with 2 "BEEP" sounds and the eco function will be disabled.
The fan will always be in operation, even if the set ambient temperature is reached.

By repeating steps 1 and 2, the indoor unit will respond with 4 "BEEP" sounds and the eco function will be reactivated.
The fan will be stopped when the set ambient temperature is reached.

Indoor-outdoor units

AS20PBAHRA (2,0 Kw) - Only Multisystem

AS25PBPBPHRA-PRE / 1U25YEPFRA-PRE (2,5 kW)

AS35PBPBPHRA-PRE / 1U35MEPFRA-PRE (3,5 kW)

AS50PDPHRA-PRE / 1U50KEPFRA-PRE (5,0 kW)

AS71PEPHRA-PRE / 1U71WEPFRA-PRE (7,1 kW)

INDOOR UNIT			AS20PBAHRA	AS25PBPBPHRA-PRE	AS35PBPBPHRA-PRE	AS50PDPHRA-PRE	AS71PEPHRA-PRE
OUTDOOR UNIT			Only Multisystem	1U25YEPFRA-PRE	1U35MEPFRA-PRE	1U50KEPFRA-PRE	1U71WEPFRA-PRE
Indoor unit technical data							
Treated air volume	H	m ³ /h	550	550	640	830	910
Net dimensions	WxDxH	mm	805x200x292	805x200x292	805x200x292	975x220x318	1105x240x335
Net / gross weight		kg	-	8,1 / 10,3	8,6 / 10,8	11,6 / 14,4	15,4 / 18,9
Outdoor unit technical data							
Liquid pipe Ø		mm (inch)	-	6,35 (1/4)	6,35 (1/4)	6,35 (1/4)	9,52 (3/8)
Gas pipe Ø		mm (inch)	-	9,52 (3/8)	9,52 (3/8)	12,70 (1/2)	15,88 (5/8)
Standard pipe length without refrigerant charge		m	-	5	5	7	7
Maximum pipe length		m	-	20	20	25	25
Minimum pipe length		m	5	5	5	5	5
Power Supply		Ph / V / Hz	-	1 / 220~240 / 50	1 / 220~240 / 50	1 / 220~240 / 50	1 / 220~240 / 50
Net / gross weight		kg	-	24,6 / 27	28,5 / 31,4	37,8 / 40,5	43,0 / 47,0
Additional ref. charge over std length		g/m	-	20	20	20	20

DIAGNOSTICS 2.5 KW - 3.5 KW - 5.0 KW - 7.1 KW

For diagnostics, see **pages 30 - 31**.

See the list of alarms on **page 13**.

IU CIRCUIT DIAGRAM 2.5 KW - 3.5 KW - 5.0 KW - 7.1 KW

AS20PBAHRA

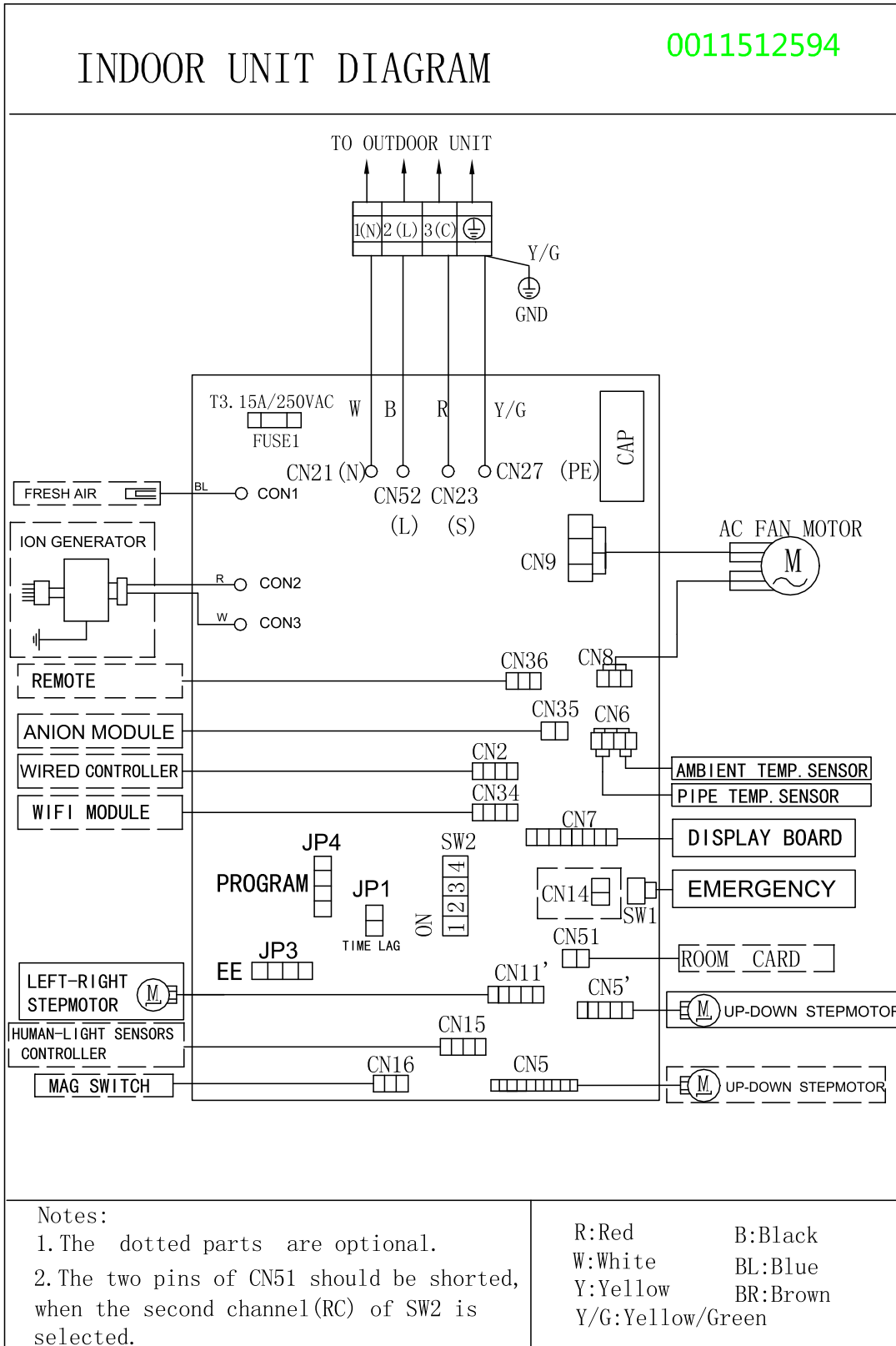

IU CIRCUIT DIAGRAM 2.5 KW - 3.5 KW - 5.0 KW - 7.1 KW

AS25PBPHRA-PRE AS35PBPHRA-PRE AS50DPHRA-PRE AS71PEPHRA-PRE

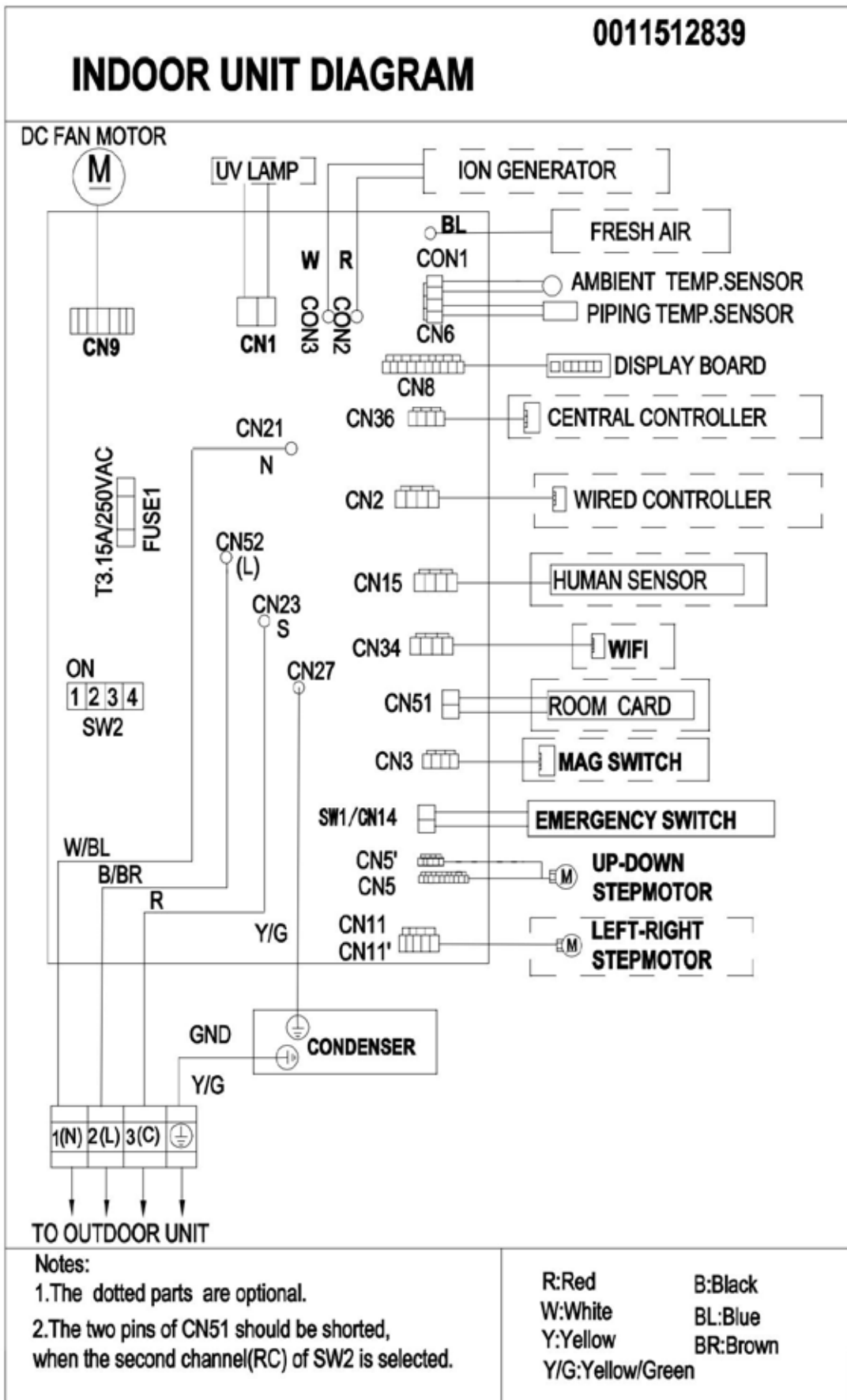

INDOOR UNIT SETTING:

Selecting the ambient temperature:

After turning to the automation mode, the running mode can be switched between cooling mode, fan mode and heating mode according to the change of the indoor ambient temperature. The automatic conversion between cooling mode and heating mode must be conducted after 15 minutes. The inlet temperature sensor doesn't work, the indoor fan and the indoor air direction board motor works synchronically. High speed airflow, cooling, outdoor system on, etc, will send the ambient temperature 30 centigrade and coil temperature 16 centigrade information to the outdoor system.

Jumper J1 and J2 combined control, corresponding to different series of display boards; ON means keep, OFF means cut.

PCB (1): Indoor Control PCB

1. CN14: Connector for Forced operation ON/OFF switch
2. FUSE1: Fuse 3.15A/250VAC
3. Pin-1: OFF match A code remote control; ON-match B code remote control Pin-2: OFF no room card control; ON-with room card control. Pin-3 and Pin-4 combined control, corresponding to 23, 26, 33 and 35 of the machine respectively
4. Jumper J1 and J2 combined control, corresponding to different series of display boards; ON means keep; OFF means cut

	OFF	ON	3	ON	ON	OFF	OFF
1	A	B	4	ON	OFF	ON	OFF
2	N-RC	RC		35	33	26	23

J1	OFF	ON	3	ON
J2	A	B	4	ON
DISPLAY SERIES	325/498	324	387/1045/989	317

UNIT MODULE	1	2	3	4	J1	J2
AS25PBPHRA-PRE	OFF	ON	OFF	OFF	ON	OFF
AS35PBPHRA-PRE	OFF	ON	OFF	OFF	ON	OFF
AS50PDPHRA-PRE	OFF	ON	ON	OFF	ON	OFF
AS71PEPHRA-PRE	OFF	ON	ON	ON	ON	OFF

Indoor-outdoor units

AS25RBAHRA-3 / 1U25YEGFRA-3 (2,5 kW)

AS35RBAHRA-4 / 1U35YESFRA-4 (3,5 kW)

AS50RCBHRA-4 / 1U50MERFRA-4 (5,0 kW)

AS68RDAHRA-4 / 1U68MRAFRA-4 (6,8 kW)

INDOOR UNIT			AS25RBAHRA-3	AS35RBAHRA-4	AS50RCBHRA-4	AS68RDAHRA-4
OUTDOOR UNIT			1U25YEGFRA-3	1U35YESFRA-4	1U50MERFRA-4	1U68MRAFRA-4
Indoor unit technical data						
Treated air volume	H	m ³ /h	610/550	620	770/810	1100/1000
Net dimensions	WxDxH	mm	805x199x292	805x199x292	875x212x304	975x222x318
Net / gross weight		kg	8,8/10,5	8,8/10,9	10,0/12,0	11,6/14,4
Outdoor unit technical data						
Liquid pipe Ø		mm (inch)	6,35 (1/4)	6,35 (1/4)	6,35 (1/4)	6,35 (1/4)
Gas pipe Ø		mm (inch)	9,52 (3/8)	9,52 (3/8)	12,70 (1/2)	12,70 (1/2)
Standard pipe length without refrigerant charge		m	5	5	7	7
Maximum pipe length		m	20	20	20	25
Minimum pipe length		m	5	5	5	5
Power Supply		Ph / V / Hz	1 / 220~240 / 50	1 / 220~240 / 50	1 / 220~240 / 50	1 / 220~240 / 50
Net / gross weight		kg	23,6 / 26	22,0 / 24,6	29,2 / 32,1	32,7 / 36,5
Additional ref. charge over std length		g/m	20	20	20	20

DIAGNOSTICS 2.5 KW - 3.5 KW - 5.0 KW - 6.8 KW

For diagnostics, see **pages 30 - 31**.

See the list of alarms on **page 13**.

IU CIRCUIT DIAGRAM 2.5 KW - 3.5 KW - 5.0 KW - 7.1 KW

AS25RBAHRA-3 AS35RBAHRA-4

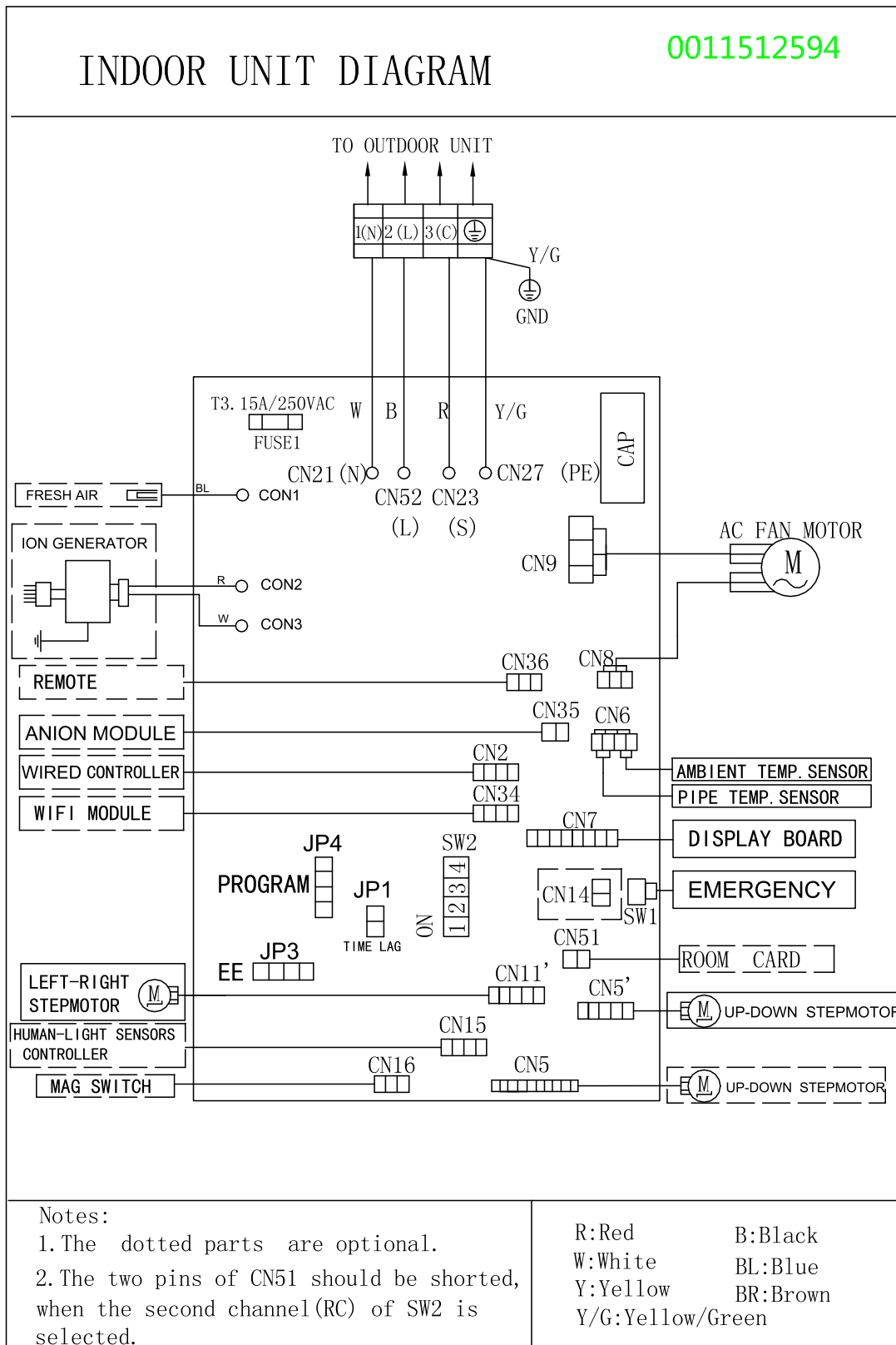

IU CIRCUIT DIAGRAM 2.5 KW - 3.5 KW - 5.0 KW - 7.1 KW

AS50RCBHRA-4 AS68RDAHRA-4

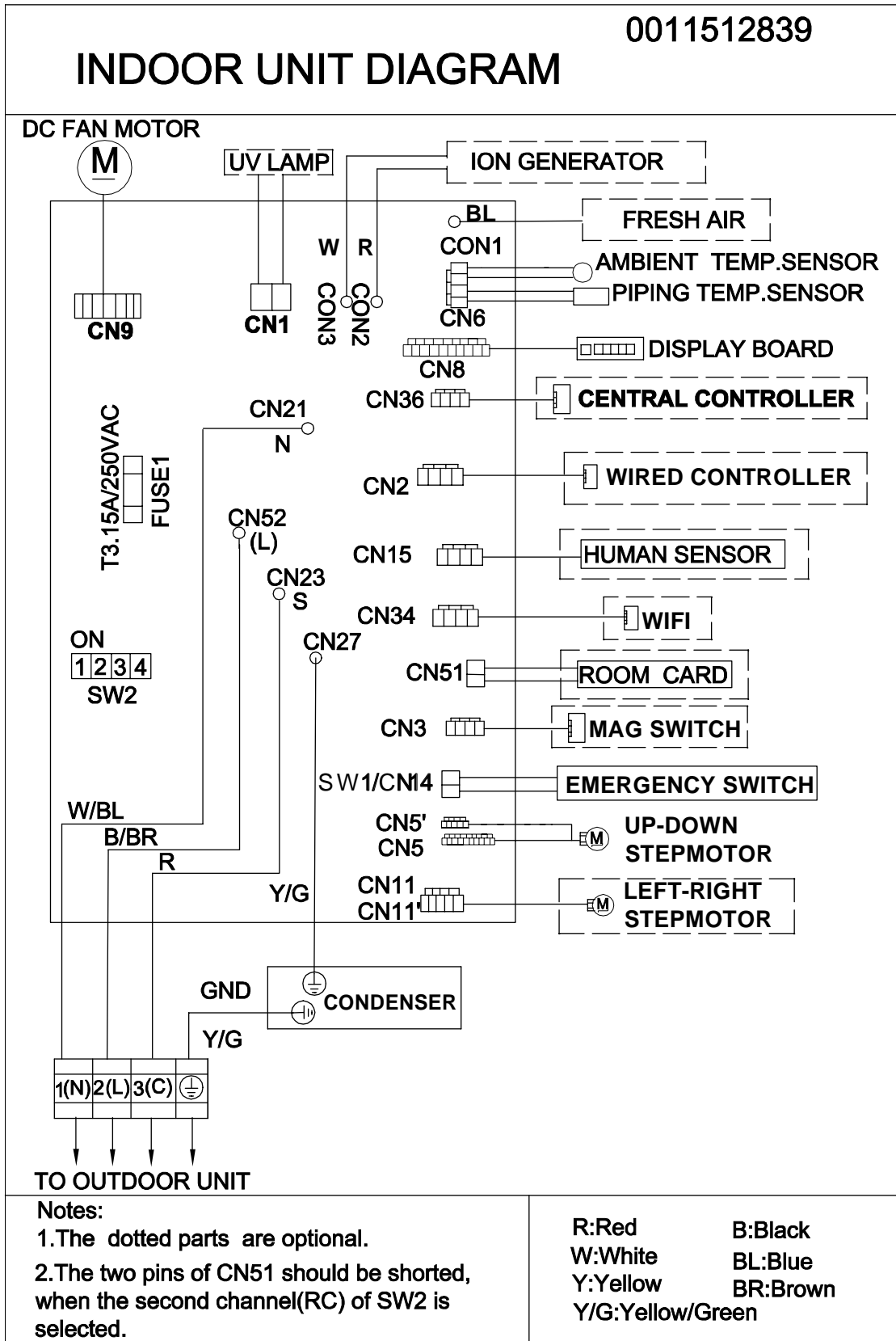

INDOOR UNIT SETTING:

For models AS25RBAHRA-3; AS35RBAHRA-4:

	OFF	ON	3	OFF	OFF	ON	ON
1	A	B	4	ON	OFF	OFF	ON
2	N-RC	RC		26	23	33	35

J1	ON	OFF	OFF	ON
J2	OFF	OFF	ON	ON
DISPLAY SERIES	387/1045/989	325/789	324	317

For models AS50RCBHRA-4; AS68RDAHRA-4:

	OFF	ON	3	ON	ON	OFF	OFF
1	A	B	4	ON	OFF	ON	OFF
2	N-RC	RC		35	33	26	23

J1	OFF	OFF	ON	ON
J2	OFF	ON	OFF	ON
DISPLAY SERIES	325/798	324	387/1045/989	317

UNIT MODULE	1	2	3	4	J1	J2
AS25RBAHRA-3	OFF	ON	ON	OFF	ON	OFF
AS35RBAHRA-4	OFF	ON	ON	ON	ON	OFF
AS50RCBHRA-4	OFF	ON	ON	ON	ON	OFF
AS68RDAHRA-4	OFF	ON	OFF	ON	ON	OFF

Indoor-outdoor units

AF25S2SD1FA(D) / 1U25S2SM1FA-2 (STANDARD) 1U25MEHFRA-1 (NORDIC) (2.5 kW)

AF35S2SD1FA(D) / 1U35S2SM1FA-2 (STANDARD) 1U35MEHFRA-1 (NORDIC) (3.5 kW)

AF42S2SD1FA(D) / 1U42S2SM1FA (4.2 kW)

AF50S2SD1FA(D) / 1U50S2SJ2FA-2 (5.8 kW)

INDOOR UNIT			AF25S2SD1FA(D)	AF35S2SD1FA(D)	AF42S2SD1FA(D)	AF50S2SD1FA(D)
OUTDOOR UNIT			1U25S2SM1FA-2	1U35S2SM1FA-2	1U42S2SM1FA	1U50S2SJ2FA-2
OUTDOOR UNIT NORDIC			1U25MEHFRA-1	1U35MEHFRA-1	-	-
Indoor unit technical data						
Treated air volume	H	m ³ /h	450/400/350/300/250	500/450/400/350/300	580/530/480/430/380	600/550/500/450/400
Net dimensions	WxDxH	mm	700x210x600	700x210x600	700x210x600	700x210x600
Net / gross weight		kg	16,5/18,5	16,5/18,5	16,5/18,5	16,5/18,5
Outdoor unit technical data						
Liquid pipe Ø		mm (inch)	6,35 (1/4)	6,35 (1/4)	6,35 (1/4)	6,35 (1/4)
Gas pipe Ø		mm (inch)	9,52 (3/8)	9,52 (3/8)	9,52 (3/8)	9,52 (3/8)
Standard pipe length without refrigerant charge		m	7	7	7	7
Maximum pipe length		m	20	20	20	25
Minimum pipe length		m	5	5	5	5
Power Supply		Ph / V / Hz	1 / 220-240 / 50	1 / 220-240 / 50	1 / 220-240 / 50	1 / 220-240 / 50
Net / gross weight		kg	27,6 / 30,4	30 / 32,9	31,5 / 34,0	35,7 / 38,5
Additional ref. charge over std length		g/m	20	20	20	20

DIAGNOSTICS 2.5 KW - 3.5 KW - 4.2 KW - 5.0 KW

For diagnostics, see **pages 28 - 29**.

See the list of alarms on **page 13**.

IU CIRCUIT DIAGRAM 2.5 KW - 3.5 KW - 4.2 KW - 5.0 KW

AF25S2SD1FA(H) AF35S2SD1FA(H) AF42S2SD1FA(H) AF50S2SD1FA(H)

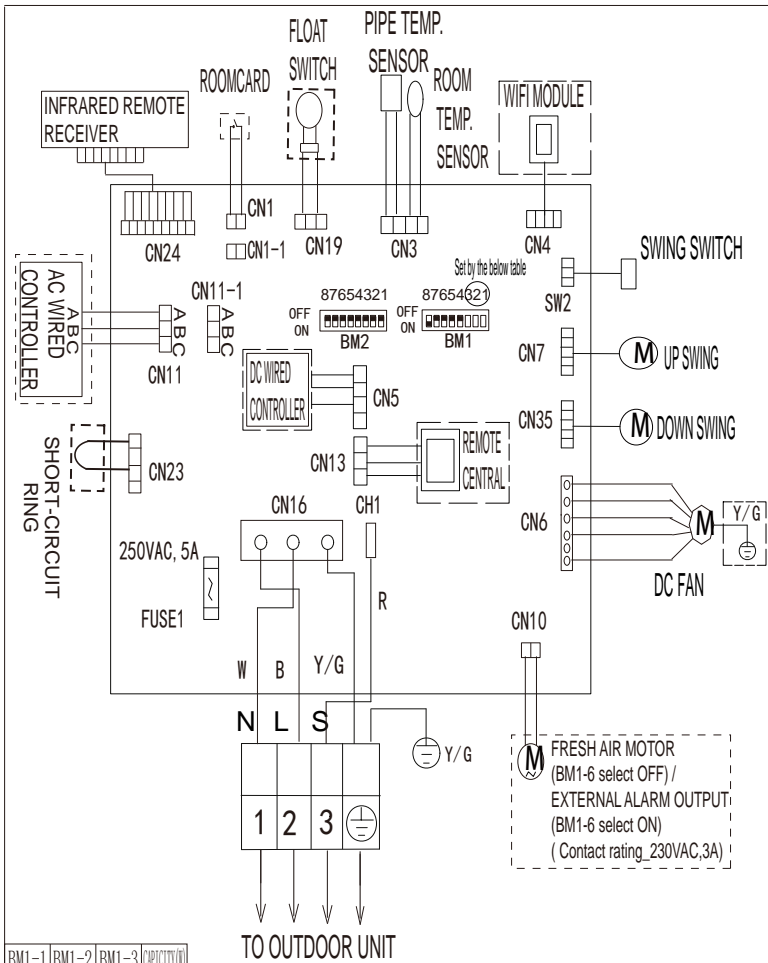

INDOOR UNIT TROUBLE SHOOTING

LED flash times of indoor PCB		Malfunction display	Contents of Malfunction	Possible reasons
LED6	LED1			
0	1	E1	Malfunction of indoor unit ambient temperature sensor	Sensor disconnected, or broken, or at wrong position, or short circuit
0	2	E2	Malfunction of indoor unit piping temperature sensor	Sensor disconnected, or broken, or at wrong position, or short circuit
0	4	E4	EEPROM wrong of indoor PCB	EEPROM chip disconnected or broken or wrong programmed, or PCB broken
0	7	E7	Abnormal communication between indoor and outdoor units	Wrong connection, or the wires be disconnected or wrong address setting of indoor unit or faulty power supply or faulty PCB or slave unit malfunction in MAXI system
0	8	E8	Abnormal communication between wired controller and indoor unit	Wrong connection or wired controller broken, or PCB faulty
0	12	E10	Malfunction of drain system	Pump motor disconnected or at wrong position, or the float switch, disconnected, or at wrong position, or the short circuit bridge disconnected
0	13	C1	Zero cross signal wrong	Zero cross signal detected wrong
0	14	E14	Indoor unit DC fan motor abnormal	DC Fan motor disconnected or DC Fan broken or circuit broken

BM1-1	BM1-2	BM1-3	CAPACITIVITY	
OFF	OFF	OFF	2500	AF25S2SD1FA(H)
ON	OFF	OFF	3500	AF35S2SD1FA(H)
OFF	ON	OFF	4200	AF42S2SD1FA(H)
OFF	ON	OFF	5000	AF50S2SD1FA(H)

NOTE: 1. DASHED PARTS ARE OPTIONAL.
2. USER SHOULD NOT CHANGE THE DIP SWITCH BM1 AND BM2 WITHOUT GUIDANCE.

BM1-4	Room card	BM1-5	Cooling Heating	BM1-6	BM1-7	BM1-8	TYPE DEFINE
OFF	Available	ON	Cooling only available	OFF	OFF	ON	Console
ON	Unavailable	OFF	Cooling & Heating	OFF	OFF	ON	Console

R: RED B: BLACK
W: WHITE
Y/G: YELLOW/GREEN
DC: DIRECT-CURRENT
AC: ALTERNATING-CURRENT
TEMP.: TEMPERATURE

Note:
1. The outdoor failure can also be indicated by the indoor unit, the checking method as follows: LED6 flash times stands for tens digit, and LED1 flash times stands for units digit, use this bidigitate figure minus 20, then will get the outdoor error code. For example, if the outdoor error code is 15, LED6 will flash 3 times firstly, two seconds later, LED1 will flash 5 times, and four seconds later the process will repeat again.
2. LED6 is a green one on the indoor PCB, LED1 is a yellow one.
3. To get much more details about the outdoor unit failure, please refer to the outdoor unit trouble shooting list.

0150570248

IU CIRCUIT DIAGRAM 2.5 KW - 3.5 KW - 4.2 KW - 5.0 KW

AF25S2SD1FA(D) AF35S2SD1FA(D) AF42S2SD1FA(D) AF50S2SD1FA(D)

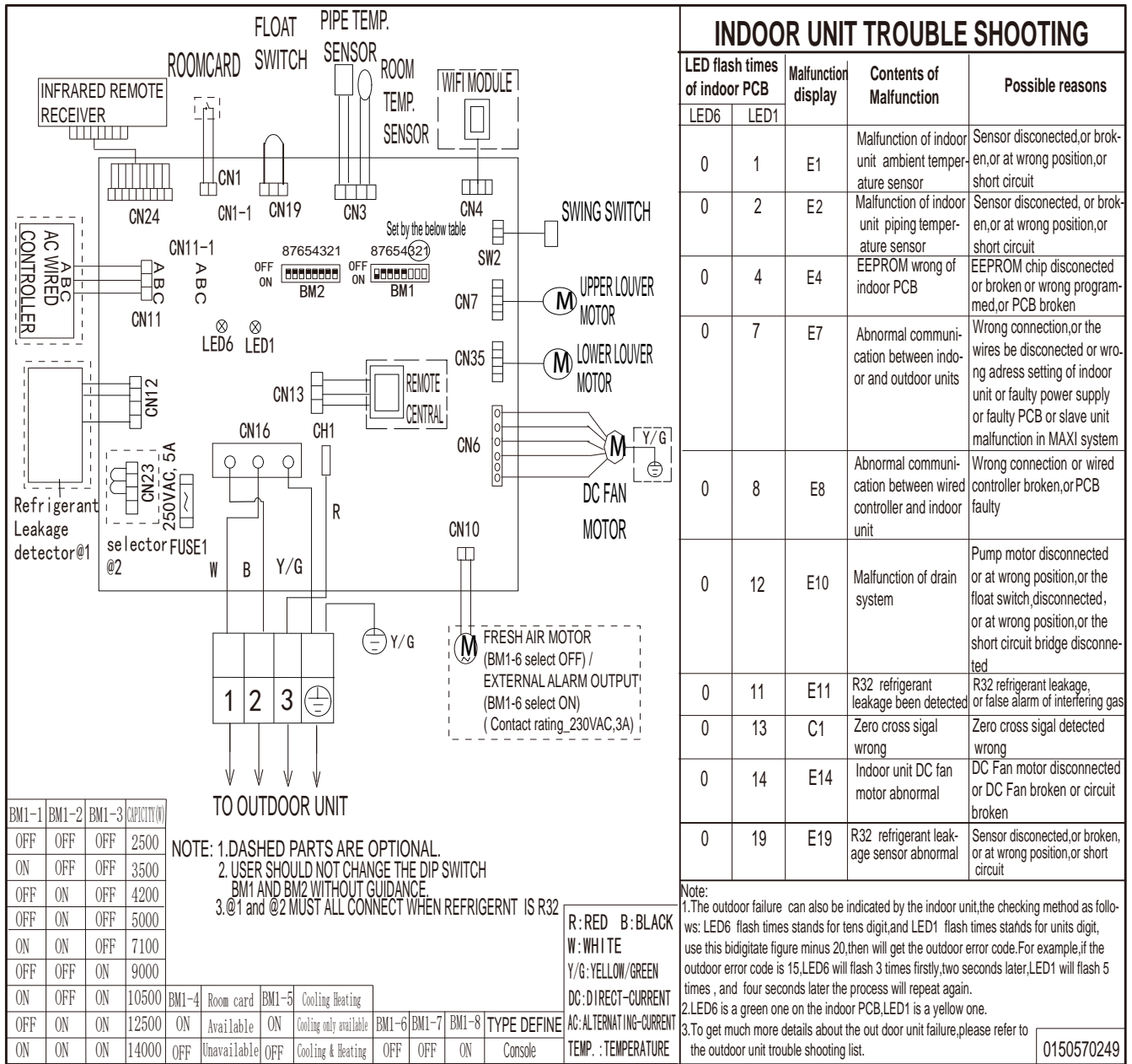

0150570249

INDOOR UNIT SETTING:

For models AS25RBAHRA-3; AS35RBAHRA-4:

	OFF	ON	3	OFF	OFF	ON	ON
1	A	B	4	ON	OFF	OFF	ON
2	N-RC	RC		26	23	33	35

J1	ON	OFF	OFF	ON
J2	OFF	OFF	ON	ON
DISPLAY SERIES	387/1045/989	325/789	324	317

For models AS50RCBHRA-4; AS68RDAHRA-4:

	OFF	ON	3	ON	ON	OFF	OFF
1	A	B	4	ON	OFF	ON	OFF
2	N-RC	RC		35	33	26	23

J1	OFF	OFF	ON	ON
J2	OFF	ON	OFF	ON
DISPLAY SERIES	325/798	324	387/1045/989	317

Indoor-outdoor units

AB25S2SA1FA(H) / 1U25S2SM1FA-2 (2.5 kW)

AB35S2SA1FA(H) / 1U35S2SM1FA-2 (3.5 kW)

AB50S2SA1FA(H) / 1U50S2SJ2FA-2 (5.0 kW)

AB71S2SA1FA(H) / 1U71S2ST1FA (7.1 kW)

INDOOR UNIT			AB25S2SA1FA(H)	AB35S2SA1FA(H)	AB50S2SA1FA(H)	AB71S2SA1FA(H)
OUTDOOR UNIT			1U25S2SM1FA-2	1U35S2SM1FA-2	1U50S2SJ2FA-2	1U71S2ST1FA
Indoor unit technical data						
Treated air volume	H	m ³ /h	500/450/400/350	560/500/450/400	850/700/550/450	900/700/600/500
Net dimensions	WxDxH	mm	850x540x185	850x540x185	1170x540x185	1170x540x185
Net / gross weight		kg	20,8/24,9	20,8/24,9	26/31	27/32
Outdoor unit technical data						
Liquid pipe Ø		mm (inch)	6,35 (1/4)	6,35 (1/4)	6,35 (1/4)	9,52 (3/8)
Gas pipe Ø		mm (inch)	9,52 (3/8)	9,52 (3/8)	12,70 (1/2)	15,88 (5/8)
Standard pipe length without refrigerant charge		m	7	7	7	7
Maximum pipe length		m	20	20	25	50
Minimum pipe length		m	5	5	5	5
Power Supply		Ph / V / Hz	1 / 220~240 / 50	1 / 220~240 / 50	1 / 220~240 / 50	1 / 220~240 / 50/60
Net / gross weight		kg	20,8 / 24,9	20,8 / 24,9	26 / 31	27 / 32
Additional ref. charge over std length		g/m	20	20	20	45

DIAGNOSTICS 2.5 KW - 3.5 KW - 5.0 KW - 7.1 KW

For diagnostics, see **pages 28 - 29**.

See the list of alarms on **page 13**.

IU CIRCUIT DIAGRAM 2.5 KW - 3.5 KW - 5.0 KW - 7.1 KW

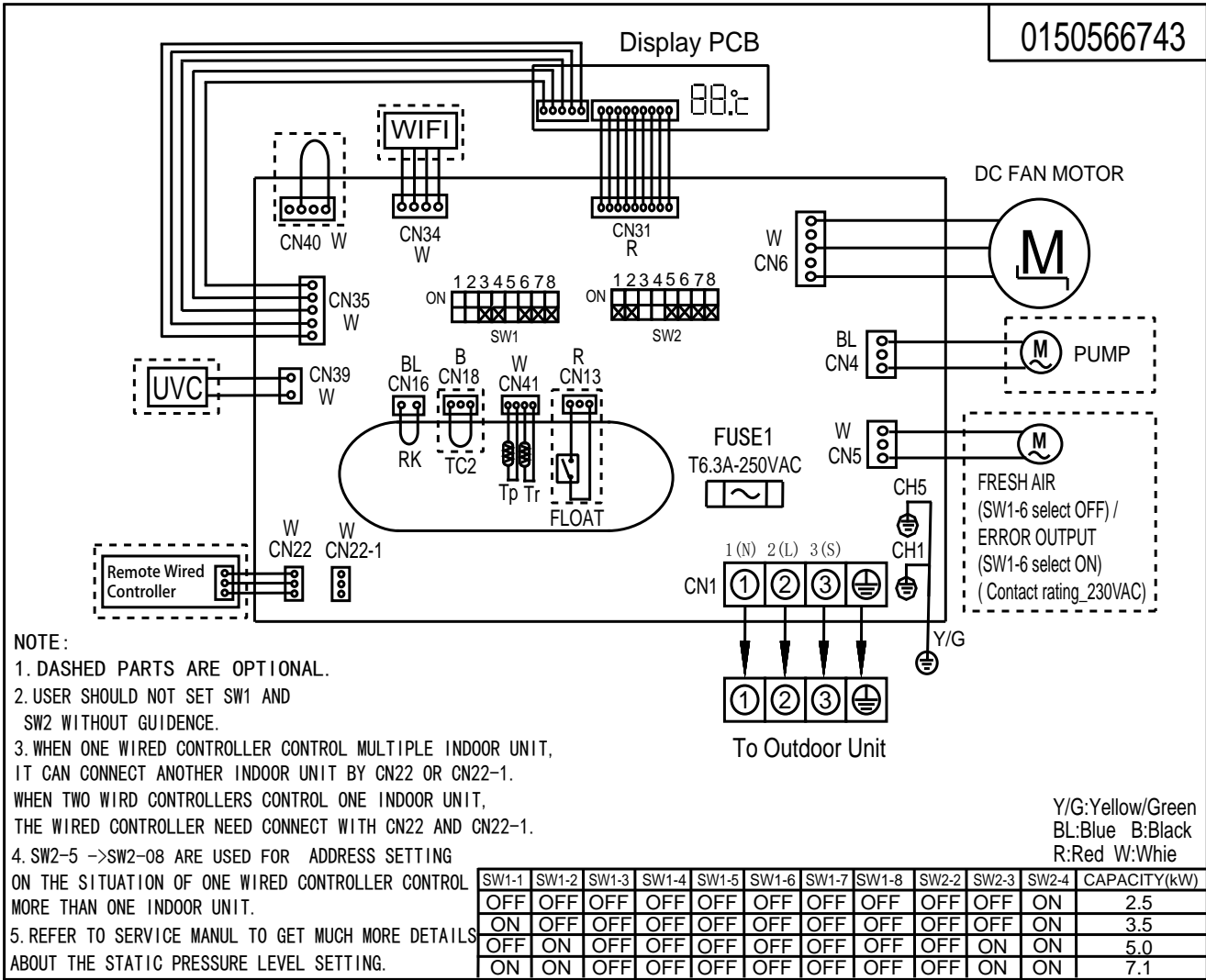

Indoor-outdoor units

AB25S2SC2FA(H) / 1U25S2SM1FA-2 (2.5 kW)

AB35S2SC2FA(H) / 1U35S2SM1FA-2 (3.5 kW)

AB50S2SC2FA(H) / 1U50S2SJ2FA-2 (5.0 kW)

INDOOR UNIT			AB25S2SC2FA(H)	AB35S2SC2FA(H)	AB50S2SC2FA(H)
OUTDOOR UNIT			1U25S2SM1FA-2	1U35S2SM1FA-2	1U50S2SJ2FA-2
Indoor unit technical data					
Treated air volume	H	m ³ /h	580/480/380/280	620/520/450/350	700/620/500/400
Net dimensions	WxDxH	mm	570x570x260	570x570x260	570x570x260
Net / gross weight		kg	18,5/22	18,5/22	19,0/22,0
Outdoor unit technical data					
Liquid pipe Ø		mm (inch)	6,35 (1/4)	6,35 (1/4)	6,35 (1/4)
Gas pipe Ø		mm (inch)	9,52 (3/8)	9,52 (3/8)	12,70 (1/2)
Standard pipe length without refrigerant charge		m	7	7	7
Maximum pipe length		m	20	20	25
Minimum pipe length		m	5	5	5
Power Supply		Ph / V / Hz	1 / 220-240 / 50	1 / 220-240 / 50	1 / 220-240 / 50
Net / gross weight		kg	27,6 / 30,4	30 / 32,9	35,7 / 38,5
Additional ref. charge over std length		g/m	20	20	20

DIAGNOSTICS 2.5 KW - 3.5 KW - 5.0 KW

For diagnostics, see **pages 28 - 29**.

See the list of alarms on **page 13**.

IU CIRCUIT DIAGRAM 2.5 KW - 3.5 KW - 5.0 KW

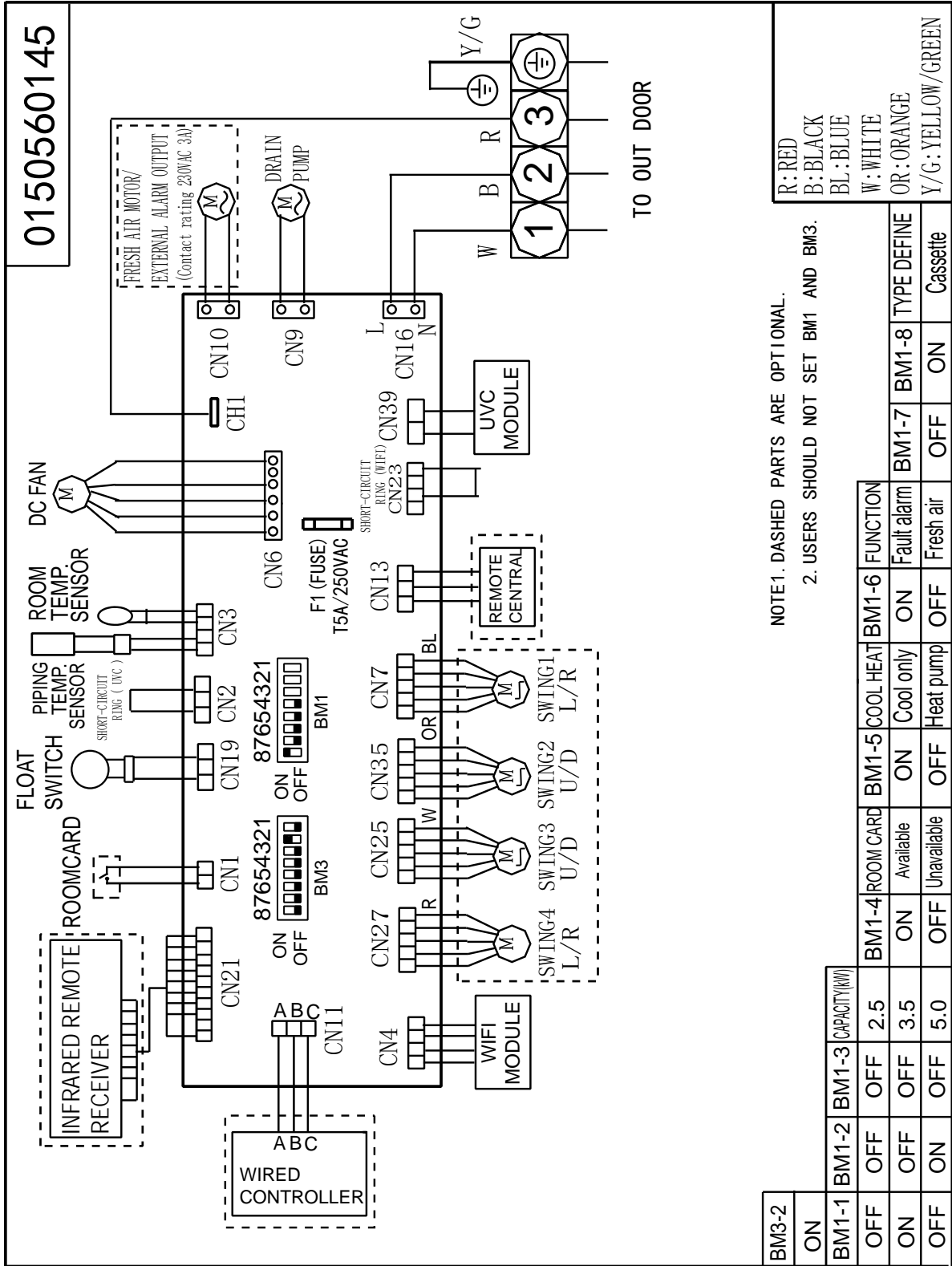

NOTE1. DASHED PARTS ARE OPTIONAL.

2. USERS SHOULD NOT SET BM1 AND BM3.

BM3-2	ON	BM1-3	CAPACITY(KW)	BM1-4	ROOM CARD	BM1-5	COOL HEAT	BM1-6	FUNCTION
BM1-1	OFF	BM1-2	OFF	2.5	ON	ON	COOL only	BM1-7	BM1-8
ON	OFF	OFF	3.5	Available	ON	ON	Heat pump	OFF	ON
OFF	ON	OFF	5.0	Unavailable	OFF	OFF	Fresh air	OFF	Cassette

R: RED
B: BLACK
BL: BLUE
W: WHITE
OR: ORANGE
Y/G: YELLOW/GREEN

Indoor-outdoor units

Roundflow Cassette Panel PB-950KB(H)	ABH125K1ERG(H) / 1U125S2SN2FB (12.5 kW)
Roundflow Cassette Panel Black PB-950KB(B)	ABH140K1ERG(H) / 1U140S2SN1FA (14 kW)
AB71S2SG1FA(H) / 1U71S2ST1FA (7.1 kW)	ABH140K1ERG(H) / 1U140S2SN1FB (14 kW)
ABH105H1ERG(H) / 1U105S2SS2FA (10.5 kW)	ABH140K1ERG(H) / 1U140S2SP2FA
ABH105H1ERG(H) / 1U105S2SS1FB (10.5 kW)	ABH140K1ERG(H) / 1U140S2SP2FB
ABH125K1ERG(H) / 1U125S2SN2FA (12.5 kW)	ABH160K1ERG(H) / 1U160S2SP1FB

INDOOR UNIT	AB71S2SG1FA(H)	ABH105H1ERG(H)	ABH105H1ERG(H)	ABH125K1ERG(H)	ABH125K1ERG(H)
OUTDOOR UNIT	1U71S2SR2FA	1U105S2SS2FA	1U105S2SS1FB	1U125S2SN2FA	1U125S2SN2FB

Indoor unit technical data						
Treated air volume	H	m ³ /h	1260/1070/820/680	1680/1530/1320/1190	1680/1530/1320/1190	1950/1600/1440/1200
Net dimensions	WxDxH	mm	840x840x204	840x840x246	840x840x246	840x840x288
Net / gross weight		kg	27,0/32,0	31,0/36,0	31,0/36,0	32,0/38,0

Outdoor unit technical data						
Liquid pipe Ø		mm (inch)	9,52 (3/8)	9,52 (3/8)	9,52 (3/8)	9,52 (3/8)
Gas pipe Ø		mm (inch)	15,88 (5/8)	15,88 (5/8)	15,88 (5/8)	15,88 (5/8)
Standard pipe length without refrigerant charge		m	10	30	30	30
Maximum pipe length		m	50	50	50	50
Minimum pipe length		m	5	5	5	5
Power Supply		Ph / V / Hz	1/220~240/50/60	1/220~240/50/60	1/220~240/50/60	1/220~240/50/60
Net / gross weight		kg	44,0/48,0	60,0/65,0	61,0/66,0	84,0/89,0
Additional ref. charge over std length		g/m	45	45	45	45

INDOOR UNIT	ABH140K1ERG(H)	ABH140K1ERG(H)	ABH140K1ERG(H)	AC140S2SK1FA(H)	AC160S2SK1FA(H)
OUTDOOR UNIT	1U140S2SN1FA	1U140S2SN1FB	1U140S2SP2FA	1U140S2SP2FB	1U160S2SP1FB

Indoor unit technical data						
Treated air volume	H	m ³ /h	1950/1600/1440/1200	1950/1600/1440/1200	1950/1600/1440/1200	2050/1600/1440/1220
Net dimensions	WxDxH	mm	950x950x50	950x950x50	950x950x50	950x950x50
Net / gross weight		kg	32,0/38,0	32,0/38,0	32,0/38,0	32,0/38,0

Outdoor unit technical data						
Liquid pipe Ø		mm (inch)	9,52 (3/8)	9,52 (3/8)	9,52 (3/8)	9,52 (3/8)
Gas pipe Ø		mm (inch)	15,88 (5/8)	15,88 (5/8)	15,88 (5/8)	19,05 (3/4)
Standard pipe length without refrigerant charge		m	30	30	30	30
Maximum pipe length		m	70	70	70	70
Minimum pipe length		m	5	5	5	5
Power Supply		Ph / V / Hz	1 / 220~240/ 50/60	3 / 380~415/ 50/60	1/220~240/50/60	3/380~415/50/60
Net / gross weight		kg	-	-	-	-
Additional ref. charge over std length		g/m	45	45	45	60

DIAGNOSTICS 7.1KW - 10.5 KW - 12.55 KW - 14 KW - 16 KW

For diagnostics, see **page 28 - 29**.

See the list of alarms on **page 14**.

IU CIRCUIT DIAGRAM 2.5 KW - 3.5 KW - 4.2 KW - 5.0 KW

AB71S2SG1FA(H) ABH105H1ERG(H) ABH125/140/160K1ERG(H)

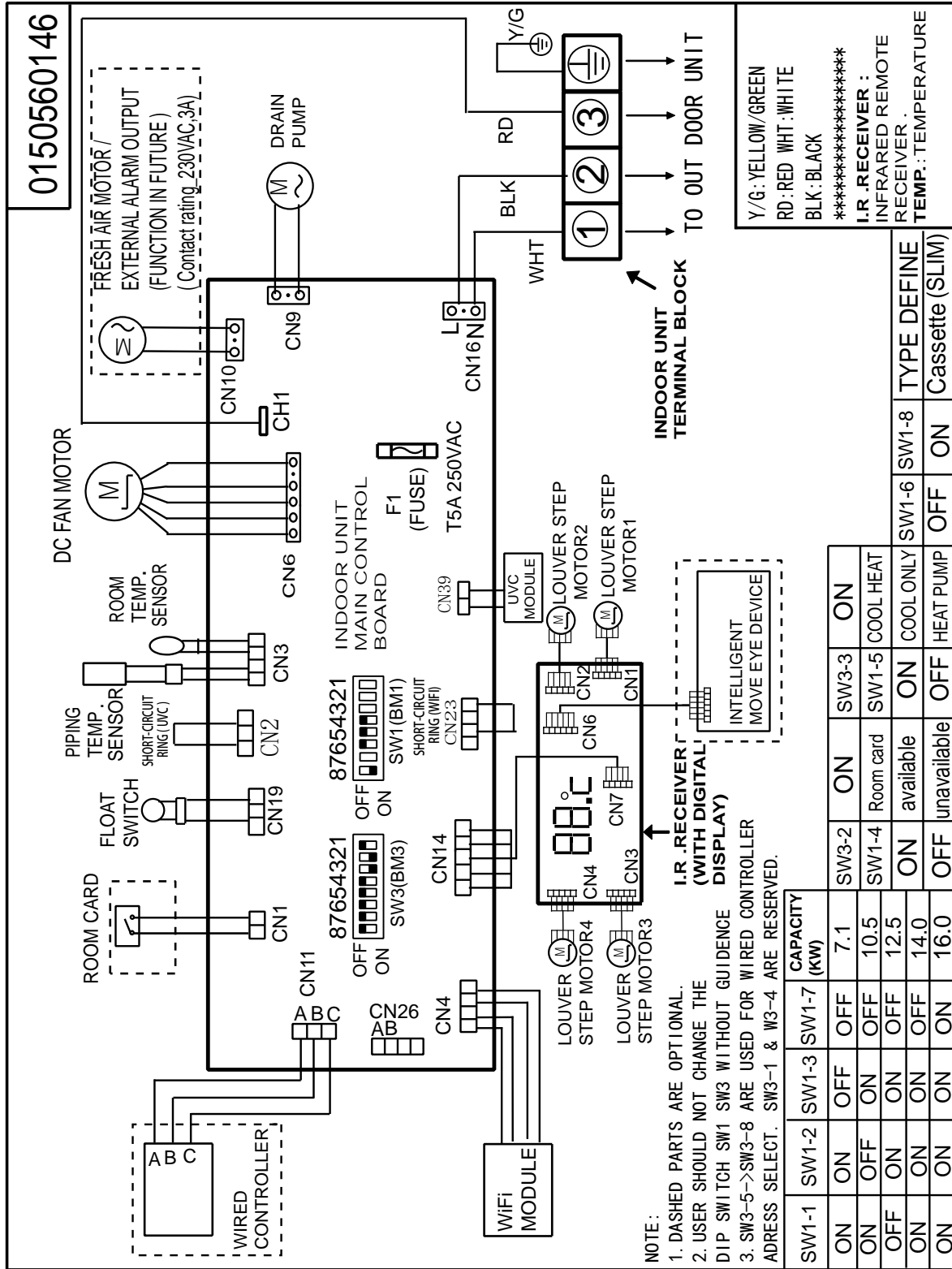

UI SETTINGS 10.5 KW - 12.5 KW - 14 KW - 16 KW

Selector Bank BM1 (SW1)

BM1 (SW1)								DESCRIPTION
Power			Room card	Mode: heating / cooling	fresh air / failure alarm			
BM1-1	BM1-2	BM1-3	BM1-4	BM1-5	BM1-6	BM1-7	BM1-8	
ON	OFF	ON	---	---	---	OFF	---	Power: 10.5 kW
OFF	ON	ON	---	---	---	OFF	---	Power: 12.5 kW
ON	ON	ON	---	---	---	OFF	---	Power: 14.0 kW
ON	ON	ON	---	---	---	ON	---	Power: 16.0 kW
---	---	---	OFF	---	---	---	---	* Room card with restart
---	---	---	ON	---	---	---	---	Room card without restart
---	---	---	---	OFF	---	---	---	Heat pump (default)
---	---	---	---	ON	---	---	---	Cooling-only
---	---	---	---	---	OFF	---	---	Fan running signal on CN5 (220 VAC) / Fresh air
---	---	---	---	---	ON	---	---	Alarm output SU CN5 (220 VAC)
---	---	---	---	---	---	OFF	---	Filter hours counter off
---	---	---	---	---	---	ON	---	Filter hours counter enabled
---	---	---	---	---	---	---	OFF	America market
---	---	---	---	---	---	---	ON	Europe market

* Room card: When the contact is closed, the unit will start again in automatic mode with set point at 24°C

Selector Bank BM3 (SW3)

Addresses for communication of multiple units with a single wired controller.

BM3 (SW3)								DESCRIPTION
BM3-1	BM3-2	BM3-3	BM3-4	BM3-5	BM3-6	BM3-7	BM3-8	
OFF	ON	ON	OFF	OFF	OFF	OFF	OFF	Master Unit
OFF	ON	ON	OFF	OFF	OFF	OFF	ON	Unit SLAVE 1
OFF	ON	ON	OFF	OFF	OFF	ON	OFF	Unit SLAVE 2
OFF	ON	ON	OFF	OFF	OFF	ON	ON	Unit SLAVE 3
OFF	ON	ON	OFF	---	---	---	---	Unit SLAVE --
OFF	ON	ON	OFF	ON	ON	ON	ON	Unit SLAVE 15

You can connect up to 16 indoor units using a single wired controller. Each unit must have its respective address:

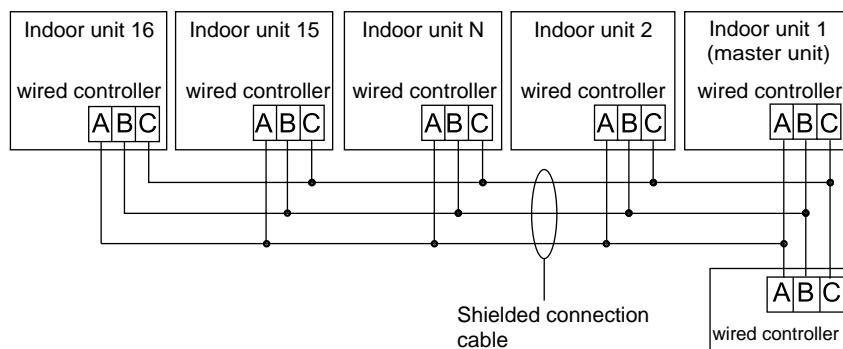

UI SETTINGS 10.5 KW - 12.5 KW - 14 KW - 16 KW

Selector Bank BM1 (SW1)

BM1 (SW1)								DESCRIPTION
Power			Room card	Mode: heating / cooling	fresh air / failure alarm			
BM1-1	BM1-2	BM1-3	BM1-4	BM1-5	BM1-6	BM1-7	BM1-8	
ON	ON	OFF	---	---	---	---	---	Power: 7.1 kW
ON	OFF	ON	---	---	---	OFF	---	Power: 10.5 kW
OFF	ON	ON	---	---	---	OFF	---	Power: 12.5 kW
ON	ON	ON	---	---	---	OFF	---	Power: 14.0 kW
ON	ON	ON	---	---	---	ON	---	Power: 16.0 kW
---	---	---	OFF	---	---	---	---	* Room card with restart
---	---	---	ON	---	---	---	---	Room card without restart
---	---	---	---	OFF	---	---	---	Heat pump (default)
---	---	---	---	ON	---	---	---	Cooling-only
---	---	---	---	---	OFF	---	---	Fan running signal on CN5 (220 VAC) / Fresh air
---	---	---	---	---	ON	---	---	Alarm output on CN5 (220 VAC)
---	---	---	---	---	---	OFF	---	Filter hours counter off
---	---	---	---	---	---	ON	---	Filter hours counter enabled
---	---	---	---	---	---	---	OFF	America market
---	---	---	---	---	---	---	ON	Europe market

*Room card: When the contact is closed, the unit will start again in automatic mode with set point at 24°C

Selector Bank BM3 (SW3)

Addresses for communication of multiple units with a single wired controller.

BM3 (SW3)								DESCRIPTION
BM3-1	BM3-2	BM3-3	BM3-4	BM3-5	BM3-6	BM3-7	BM3-8	
OFF	ON	ON	OFF	OFF	OFF	OFF	OFF	Master Unit
OFF	ON	ON	OFF	OFF	OFF	OFF	ON	Unit SLAVE 1
OFF	ON	ON	OFF	OFF	OFF	ON	OFF	Unit SLAVE 2
OFF	ON	ON	OFF	OFF	OFF	ON	ON	Unit SLAVE 3
OFF	ON	ON	OFF	---	---	---	---	Unit SLAVE --
OFF	ON	ON	OFF	ON	ON	ON	ON	Unit SLAVE 15

You can connect up to 16 indoor units using a single wired controller. Each unit must have its respective address:

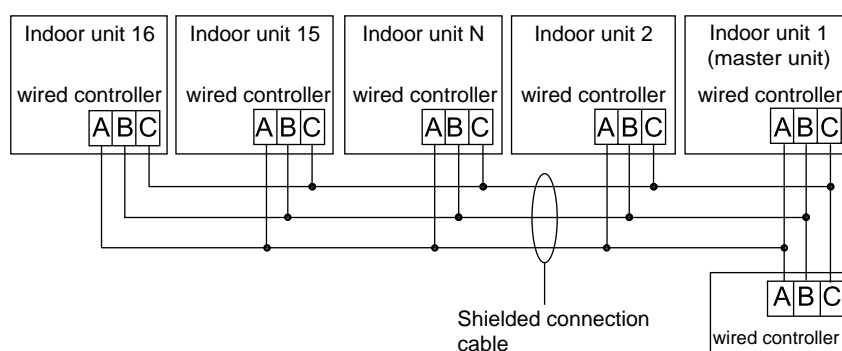

Indoor-outdoor units

AC25S2SG1FA(H) / 1U25S2SM1FA-2 (2.5 kW)
AC35S2SG1FA(H) / 1U35S2SM1FA-2 (3.5 kW)
AC50S2SG1FA(H) / 1U50S2SJ2FA-2 (5.0 kW)
AC71S2SG1FA(H) / 1U71S2ST1FA (7.1 kW)
AC105S2SH1FA(H) / 1U105S2SS2FA (10.5 kW)
AC105S2SH1FA(H) / 1U105S2SS1FB (10.5 kW)
AC125S2SK1FA(H) / 1U125S2SN2FA (12.5 kW)

AC125S2SK1FA(H) / 1U125S2SN2FB (12.5 kW)
AC140S2SK1FA(H) / 1U140S2SN1FA (14.0 kW)
AC140S2SK1FA(H) / 1U140S2SN1FB (14.0 kW)
AC140S2SK1FA(H) / 1U140S2SP2FA (14.0 kW)
AC140S2SK1FA(H) / 1U140S2SP2FB (14.0 kW)
AC160S2SK1FA(H) / 1U160S2SP1FB (16.0 kW)

INDOOR UNIT			AC25S2SG1FA(H)	AC35S2SG1FA(H)	AC50S2SG1FA(H)	AC71S2SG1FA(H)	AC105S2SH1FA(H)
OUTDOOR UNIT			1U25S2SM1FA-2	1U35S2SM1FA-2	1U50S2SJ2FA-2	1U71S2ST1FA	1U105S2SS2FA
Indoor unit technical data							
Treated air volume	H	m ³ /h	580/480/380/280	750/620/500/400	880/750/650/500	1250/1128/930/840	1600/1400/1280/1160
Net dimensions	WxDxH	mm	1000x230x680	1000x230x680	1000x230x680	1000x230x680	1325x230x680
Net / gross weight		kg	26,0/32,0	26,0/32,0	26,0/32,0	33,5/41,9	33,5/41,9
Outdoor unit technical data							
Liquid pipe Ø		mm (inch)	6,35 (1/4)	6,35 (1/4)	6,35 (1/4)	9,52 (3/8)	9,52 (3/8)
Gas pipe Ø		mm (inch)	9,52 (3/8)	9,52 (3/8)	12,70 (1/2)	15,88 (5/8)	15,88 (5/8)
Standard pipe length without refrigerant charge		m	7	7	7	10	30
Maximum pipe length		m	20	20	25	50	50
Minimum pipe length		m	5	5	5	5	5
Power Supply		Ph / V / Hz	1/220~240/50	1/220~240/50	1/220~240/50	1/220~240/50/60	1/220~240/50/60
Net / gross weight		kg	27,6/30,4	30,0/32,9	35,7/38,5	44,0/48,0	60,0/65,0
Additional ref. charge over std length		g/m	20	20	20	45	45

INDOOR UNIT			AC105S2SH1FA(H)	AC125S2SK1FA(H)	AC125S2SK1FA(H)	AC140S2SK1FA(H)
OUTDOOR UNIT			1U105S2SS1FB	1U125S2SN2FA	1U125S2SN2FB	1U140S2SN1FA
Indoor unit technical data						
Treated air volume	H	m ³ /h	1600/1400/1280/1160	2050/1900/1600/1400	2050/1900/1600/1400	2150/1980/1800/1600
Net dimensions	WxDxH	mm	1325x230x680	1650x230x680	1650x230x680	1650x230x680
Net / gross weight		kg	33,5/41,9	43,0/51,0	43,0/51,0	43/51
Outdoor unit technical data						
Liquid pipe Ø		mm (inch)	9,52 (3/8)	9,52 (3/8)	9,52 (3/8)	9,52 (3/8)
Gas pipe Ø		mm (inch)	15,88 (5/8)	15,88 (5/8)	15,88 (5/8)	15,88 (5/8)
Standard pipe length without refrigerant charge		m	30	30	30	30
Maximum pipe length		m	50	50	50	70
Minimum pipe length		m	5	5	5	5
Power Supply		Ph / V / Hz	1/220~240/50/60	1/220~240/50/60	1/220~240/50/60	1/220~240/50/60
Net / gross weight		kg	61,0/66,0	84,0/89,0	85,0/90,0	84/89
Additional ref. charge over std length		g/m	45	45	45	45

INDOOR UNIT			AC140S2SK1FA(H)	AC140S2SK1FA(H)	AC140S2SK1FA(H)	AC160S2SK1FA(H)
OUTDOOR UNIT			1U140S2SN1FB	1U140S2SP2FA	1U140S2SP2FB	1U160S2SP1FB
Indoor unit technical data						
Treated air volume	H	m ³ /h	2150/1980/1800/1600	2150/1980/1800/1600	2150/1980/1800/1600	2250/2000/1850/1650
Net dimensions	WxDxH	mm	1650x230x680	1650x230x680	1650x230x680	1650x230x680
Net / gross weight		kg	43/51	43/51	43/51	43/51
Outdoor unit technical data						
Liquid pipe Ø		mm (inch)	9,52 (3/8)	9,52 (3/8)	9,52 (3/8)	9,52 (3/8)
Gas pipe Ø		mm (inch)	15,88 (5/8)	15,88 (5/8)	15,88 (5/8)	19,05 (3/4)
Standard pipe length without refrigerant charge		m	30	30	30	30
Maximum pipe length		m	70	70	70	70
Minimum pipe length		m	5	5	5	5
Power Supply		Ph / V / Hz	1/220~240/50/60	1/220~240/50/60	1/220~240/50/60	1/220~240/50/60
Net / gross weight		kg	85/90	105/118	101/116	101/116
Additional ref. charge over std length		g/m	45	45	45	60

DIAGNOSTICS 2.5 KW - 3.5 KW - 5.0 KW - 7.1 KW - 10.5 KW - 12.5 KW - 14.0 KW - 16.0 KW

For diagnostics, see **page 28 - 29**.

See the list of alarms on **page 14**.

IU CIRCUIT DIAGRAM 2.5 KW - 3.5 KW - 5.0 KW - 7.1 KW - 10.5 KW - 12.5 KW - 14.0 KW - 16.0 KW

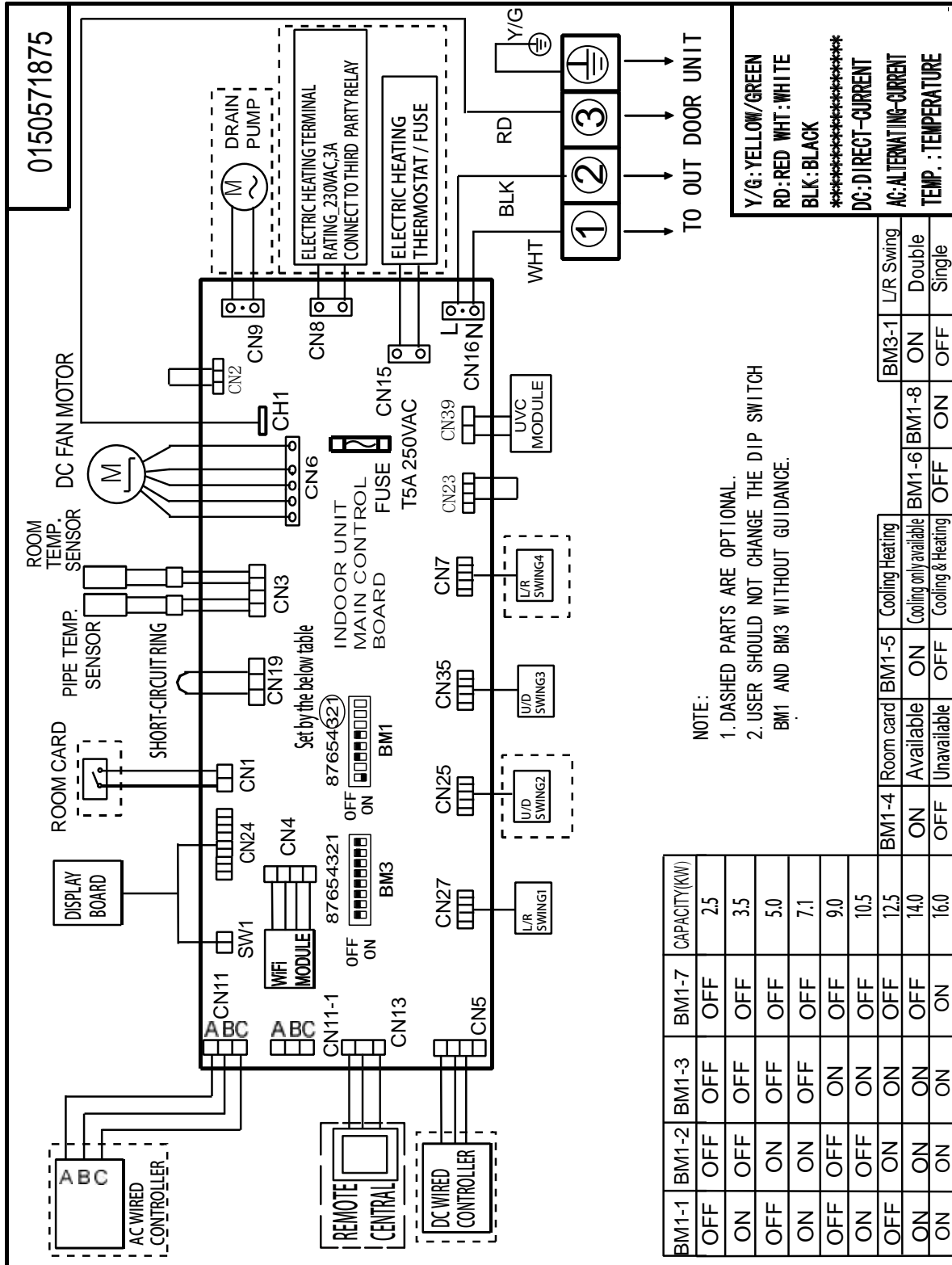

INDOOR UNIT SETTING:

BM1-1	BM1-2	BM1-3	Indoor unit power
OFF	OFF	OFF	2.5 kW
ON	OFF	OFF	3.5 kW
OFF	ON	OFF	5.0 kW
ON	ON	OFF	7.1 kW
ON	OFF	OFF	10.5 kW
OFF	ON	OFF	12.5 kW
ON	ON	OFF	14.0 kW
ON	ON	ON	16.0 kW

BM1-4	Enabling the Room-Card
ON	* Enabled
OFF	** Disabled (default)

* **Enabled:** Upon restart, the unit remains off waiting for the user to switch it on

** **Disabled:** The contact is completely inhibited

BM1-5	Cooling-only mode
ON	Cooling-only
OFF	Cooling & heat pump

BM1-6	Fresh air / alarm output
ON	Alarm output on CN5 (220 VAC)
OFF	Fan running signal on CN5 (220 VAC) / Fresh air

BM1-7	Filter hours counter
ON	Active
OFF	Inactive (default)

BM1-8	N.D.
OFF	(default)

SELECTOR BANK BM3

BM3-1	SX/DX deflector management (optional)
ON	Double
OFF	Single

UNIT ADDRESS FOR WIRED CONTROLLER

SW3(BM3) 1=ON 0=OFF								
Not used				Wired Controller Address				DESCRIPTION
BM3-1	BM3-2	BM3-3	BM3-4	BM3-5	BM3-6	BM3-7	BM3-8	
---	---	---	---	OFF	OFF	OFF	OFF	Master unit
---	---	---	---	OFF	OFF	OFF	ON	Slave address no. 1
---	---	---	---	OFF	OFF	ON	OFF	Slave address no. 2
---	---	---	---	ON	ON	ON	ON	Slave address no. 15

You can connect up to 16 indoor units using a single wired controller. Each unit must have its respective address:

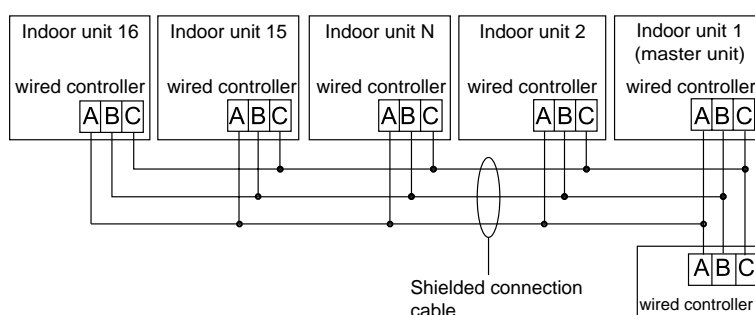

Indoor-outdoor units

AD25S2SS1FA(H) / 1U25S2SM1FA-2 (2.5 kW)

AD35S2SS1FA(H) / 1U35S2SM1FA-2 (3.5 kW)

AD50S2SS1FA(H) / 1U50S2SJ2FA-2 (5.0 kW)

AB71S2SA1FA(H) / 1U71S2ST1FA (7.1 kW)

INDOOR UNIT			AD25S2SS1FA(H)	AD35S2SS1FA(H)	AD50S2SS1FA(H)	AD71S2SS1FA(H)
OUTDOOR UNIT			1U25S2SM1FA-2	1U35S2SM1FA-2	1U50S2SJ2FA-2	1U71S2ST1FA
Indoor unit technical data						
Treated air volume	H	m ³ /h	580 / 480 / 380	600 / 480 / 420	900 / 750 / 600	1000 / 850 / 750
Net dimensions	WxDxH	mm	850x420x185	850x420x185	1170x420x185	1170x420x185
Net / gross weight		kg	16,0 / 21,0	16,0 / 21,0	22,8 / 27,0	25,2 / 28,4
Outdoor unit technical data						
Liquid pipe Ø		mm (inch)	6,35 (1/4)	6,35 (1/4)	6,35 (1/4)	9,52 (3/8)
Gas pipe Ø		mm (inch)	9,52 (3/8)	9,52 (3/8)	12,70 (1/2)	15,88 (5/8)
Standard pipe length without refrigerant charge		m	7	7	7	10
Maximum pipe length		m	20	20	25	50
Minimum pipe length		m	5	5	5	5
Power Supply		Ph / V / Hz	1 / 220~240 / 50	1 / 220~240 / 50	1 / 220~240 / 50	1 / 220~240 / 50
Net / gross weight		kg	27,6 / 30,4	30 / 32,9	35,7 / 38,5	44,0 / 48,0
Additional ref. charge over std length		g/m	20	20	20	45

DIAGNOSTICS 2.5 KW - 3.5 KW - 5.0 KW - 7.1 KW

For diagnostics, see **page 28 - 29**.

See the list of alarms on **page 14**.

IU CIRCUIT DIAGRAM 2.5 KW - 3.5 KW - 5.0 KW - 7.1 KW

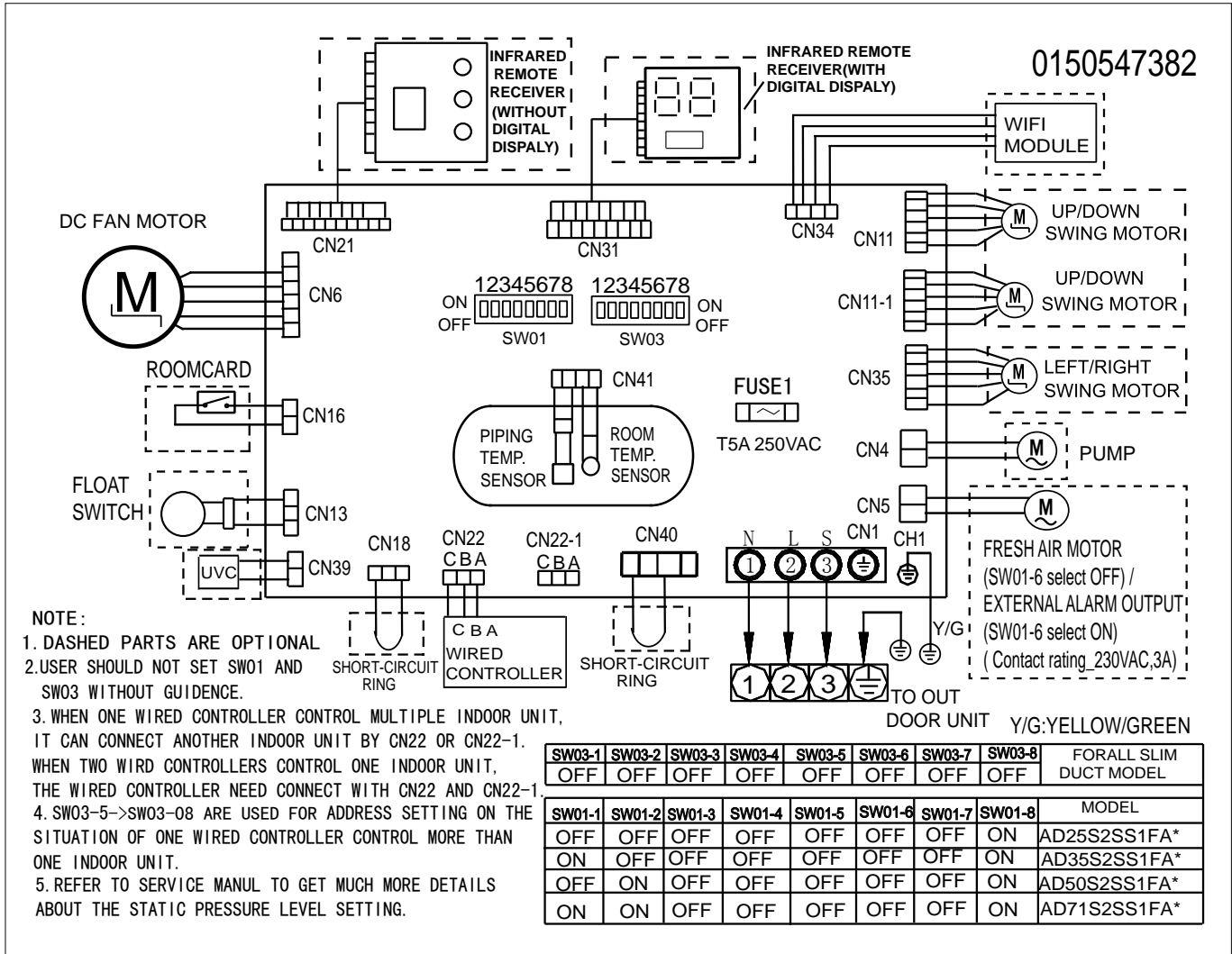

INDOOR UNIT SETTINGS 2.5 KW - 3.5 KW - 5.0 KW - 7.1 KW

SW1 SELECTOR								DESCRIPTION
SW1-1	SW1-2	SW1-3	SW1-4	SW1-5	SW1-6	SW1-7	SW1-8	
OFF	OFF	OFF	---	---	---	---	ON	POWER 2.5 kW
ON	OFF	OFF	---	---	---	---	ON	POWER 3.5 kW
OFF	ON	OFF	---	---	---	---	ON	POWER 5.0 kW
ON	ON	OFF	---	---	---	---	ON	POWER 7,1 kW
OFF	OFF	ON	---	---	---	---	---	N.D.
ON	OFF	ON	---	---	---	---	---	N.D.
OFF	ON	ON	---	---	---	---	---	N.D.
ON	ON	ON	---	---	---	---	---	N.D.
---	---	---	OFF	---	---	---	---	* ROOM CARD (RESTART WITH CONTACT CLOSED)
---	---	---	ON	---	---	---	---	ROOM CARD (STAND BY WITH CONTACT CLOSED)
---	---	---	---	OFF	---	---	---	HEAT PUMP (DEFAULT)
---	---	---	---	ON	---	---	---	COOLING-ONLY
---	---	---	---	---	OFF	---	---	FAN RUNNING SIGNAL ON CN5 (220 VAC) / FRESH AIR
---	---	---	---	---	ON	---	---	ALARM SIGNAL ON CN5 (220 VAC)
---	---	---	---	---	---	OFF	---	FILTER CLEANUP ALARM DISABLED (DEFAULT)
---	---	---	---	---	---	ON	---	FILTER CLEANUP ALERT ENABLED

* Room card: When the contact is closed, the unit will start again in automatic mode with set point at 24°C

SW3 SELECTOR								DESCRIPTION
SW3-1	SW3-2	SW3-3	SW3-4	SW3-5	SW3-6	SW3-7	SW3-8	
OFF	OFF	OFF	---	---	---	---	---	NOT USED (DEFAULT)
---	---	---	OFF	---	---	---	---	SLIM DUCTED LOW PRESSURE
---	---	---	ON	---	---	---	---	DUCTED MEDIUM PRESSURE
---	---	---	---	OFF	OFF	OFF	OFF	MASTER UNIT
---	---	---	---	OFF	OFF	OFF	ON	1 SLAVE UNIT
---	---	---	---	OFF	OFF	ON	OFF	2 SLAVE UNITS
---	---	---	---	OFF	OFF	ON	ON	3 SLAVE UNITS
---	---	---	---	OFF	ON	OFF	OFF	4 SLAVE UNITS
---	---	---	---	OFF	ON	OFF	ON	5 SLAVE UNITS
---	---	---	---	OFF	ON	ON	OFF	6 SLAVE UNITS
---	---	---	---	OFF	ON	ON	ON	7 SLAVE UNITS
---	---	---	---	ON	OFF	OFF	OFF	8 SLAVE UNITS
---	---	---	---	ON	OFF	OFF	ON	9 SLAVE UNITS
---	---	---	---	ON	OFF	ON	OFF	10 SLAVE UNITS
---	---	---	---	ON	OFF	ON	ON	11 SLAVE UNITS
---	---	---	---	ON	ON	OFF	OFF	12 SLAVE UNITS
---	---	---	---	ON	ON	OFF	ON	13 SLAVE UNITS
---	---	---	---	ON	ON	ON	OFF	14 SLAVE UNITS
---	---	---	---	ON	ON	ON	ON	15 SLAVE UNITS

SW3 UNIT ADDRESS FOR WIRED CONTROLLER (REFER TO SELECTORS SW3-5/8)

You can connect up to 16 indoor units using a single wired controller. Each unit must have its respective address:

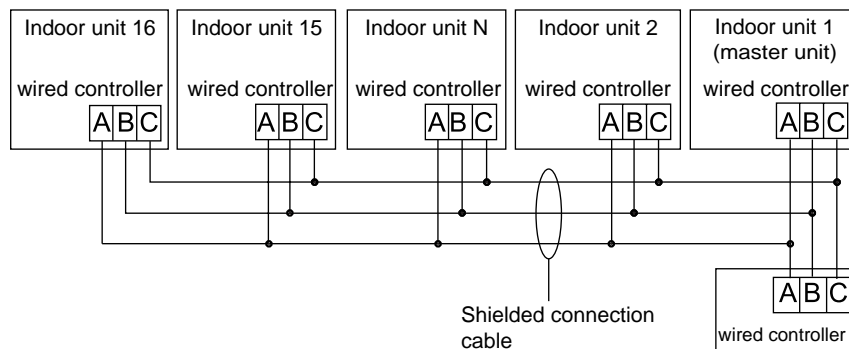

Reading and modifying the static fan pressure (wired controller)

FOR READING/MODIFYING THE STATIC PRESSURE, OPERATE DIRECTLY THROUGH THE WIRED CONTROLLER (E.G. YR E- 17)

1. With the controller on and without a screensaver active, press the "Fan" and "Set" keys for 5s at the same time; The static pressure icon flashes and its current value is displayed. Using the keys it is possible to modify the static pressure value. Press the SET key to confirm your modifications.
2. The unit number is displayed in the minutes field in the upper-left corner and the static pressure value in the minutes field of the timer field in the upper right. Press the TIME key to move to the unit number.
3. The unit number is displayed in decimal format between 00 and 15. The static pressure value is displayed in a decimal value between 01 and 04.
4. When modifying, press the ON/OFF key to exit the function and turn the unit on/off without confirming any changes.
5. The static pressure value is not retained when the auto restart function is not set.
6. The static pressure value of "slave" units, when connected in groups, is not modifiable.
7. The current/adjustable static pressure value of the indoor unit can be changed by the wired controller, only for certain models, from the advanced functions menu.

Prevalence setting of Ducted with remote control:

Set the mode: VENTILATION

Set the fan speed: HIGH

Quickly press HEALTH 4+n times, where "n" is the desired static pressure level

The Ducted responds with n+1 beeps, indicating the level set

NB:

Slim Ducted Low Pressure: 4 static pressure levels: 0/10/20/30

Medium Pressure: 10 static pressure levels: 25/37/50/70/90/100/110/120/130/150

High Pressure: 10 static pressure levels: 37/50/70/90/110/130/150/170/190/210

Example:

Slim Ducted Low Pressure AD35S2SS1FA

To set maximum static pressure:

- ventilation mode, high speed; quickly press HEALTH 4+4= 8 TIMES; the Ducted will respond with 4+1=5 BEEPs

Indoor-outdoor units

AD35S2SM3FA(H) / 1U35S2SM1FA-2 (3.5 kW)

AD50S2SM3FA(H) / 1U50S2S2FA-2 (5.0 kW)

AD71S2SM3FA(H) / 1U71S2ST1FA (7.1 kW)

AD105S2SM3FA(H) / 1U105S2SS2FA (10.5 kW)

AD105S2SM3FA(H) / 1U105S2SS1FB (10.5 kW)

AD125S2SM8FA(H) / 1U125S2SN2FA (12.5 kW)

AD125S2SM8FA(H) / 1U125S2SN2FB (12.5 kW)

AD140S2SM8FA(H) / 1U140S2SN1FA (14 kW)

AD140S2SM8FA(H) / 1U140S2SN1FB (14 kW)

AD140S2SM8FA(H) / 1U140S2SP2FA (14 kW)

AD140S2SM8FA(H) / 1U140S2SP2FB (14 kW)

AD160S2SM3FA(H) / 1U160S2SP1FB (16 kW)

INDOOR UNIT			AD35S2SM3FA(H)	AD50S2SM3FA(H)	AD71S2SM3FA(H)	AD105S2SM3FA(H)
OUTDOOR UNIT			1U35S2SM1FA-2	1U50S2S2FA-2	1U71S2ST1FA	1U105S2SS2FA
Indoor unit technical data						
Treated air volume	H	m ³ /h	840/720/600/450	1020/900/780/550	1440/1260/1100/900	1600/1480/1360/1240
Net dimensions	WxDxH	mm	700x700x248	1100x700x248	1100x700x248	1500x700x248
Net / gross weight		kg	26,0/30,0	31,0/35,0	31,0/35,0	46,0/55,0
Outdoor unit technical data						
Liquid pipe Ø		mm (inch)	6,35 (1/4)	6,35 (1/4)	9,52 (3/8)	9,52 (3/8)
Gas pipe Ø		mm (inch)	9,52 (3/8)	12,70 (1/2)	15,88 (5/8)	15,88 (5/8)
Standard pipe length without refrigerant charge		m	7	7	10	30
Maximum pipe length		m	20	25	50	50
Minimum pipe length		m	5	5	5	5
Power Supply		Ph / V / Hz	1/220~240/50	1/220~240/50	1/220~240/50/60	1/220~240/50/60
Net / gross weight		kg	30,0/32,9	35,7/38,5	44,0/48,0	60,0/65,0
Additional ref. charge over std length		g/m	20	20	45	45
INDOOR UNIT			AD105S2SM3FA(H)	AD125S2SM8FA(H)	AD125S2SM8FA(H)	AD140S2SM8FA(H)
OUTDOOR UNIT			1U105S2SS1FB	1U125S2SN2FA	1U125S2SN2FB	1U140S2SN1FA
Indoor unit technical data						
Treated air volume	H	m ³ /h	1600/1480/1360/1240	2250/1960/1680/1500	2250/1960/1680/1500	2500/2160/1780/1500
Net dimensions	WxDxH	mm	1500x700x248	1500x700x248	1500x700x248	1500x700x248
Net / gross weight		kg	46,0/55,0	48,0/57,0	48,0/57,0	48,0/57,0
Outdoor unit technical data						
Liquid pipe Ø		mm (inch)	9,52 (3/8)	9,52 (3/8)	9,52 (3/8)	9,52 (3/8)
Gas pipe Ø		mm (inch)	15,88 (5/8)	15,88 (5/8)	15,88 (5/8)	15,88 (5/8)
Standard pipe length without refrigerant charge		m	30	30	30	30
Maximum pipe length		m	50	50	50	70
Minimum pipe length		m	5	5	5	5
Power Supply		Ph / V / Hz	3/380~415/50/60 1	1/220~240/ 50/60	3/380~415/ 50/60	1/220~240/ 50/60
Net / gross weight		kg	61,0/66,0	84,0/89,0	85,0/90,0	84,0/89,0
Additional ref. charge over std length		g/m	45	45	45	45
INDOOR UNIT			AD140S2SM8FA(H)	AD140S2SM8FA(H)	AD140S2SM8FA(H)	AD160S2SM3FA(H)
OUTDOOR UNIT			1U140S2SN1FB	1U140S2SP2FA	1U140S2SP2FB	1U160S2SP1FB
Indoor unit technical data						
Treated air volume	H	m ³ /h	2500/2160/1780/1500	2500/2160/1780/1500	2500/2160/1780/1500 2500/2160/1780/1500	2500/2160/1780/1500 2500/2160/1780/1500
Net dimensions	WxDxH	mm	1500x700x248	1500x700x248	1500x700x248	1500x700x248
Net / gross weight		kg	48,0/57,0	48,0/57,0	48,0/57,0	48,0/57,0
Outdoor unit technical data						
Liquid pipe Ø		mm (inch)	9,52 (3/8)	9,52 (3/8)	9,52 (3/8)	9,52 (3/8)
Gas pipe Ø		mm (inch)	15,88 (5/8)	15,88 (5/8)	15,88 (5/8)	19,05 (3/4)
Standard pipe length without refrigerant charge		m	30	30	30	30
Maximum pipe length		m	70	70	70	70
Minimum pipe length		m	5	5	5	5
Power Supply		Ph / V / Hz	3/380~415/ 50/60	1/220~240/50/60	3/380~415/50/60	3/380~415/50/60
Net / gross weight		kg	85,0/90,0	105,0/118,0	101,0/116,0	101,0/116,0
Additional ref. charge over std length		g/m	45	45	45	60

DIAGNOSTICS 3.5 KW - 5.0 KW - 7.1 KW - 10.5 KW - 12.5 KW - 14.0 KW - 16.0 KW

For diagnostics, see **page 28 - 29**.

See the list of alarms on **page 14**.

IU CIRCUIT DIAGRAM 3.5 KW - 5.0 KW - 7.1 KW - 10.5 KW

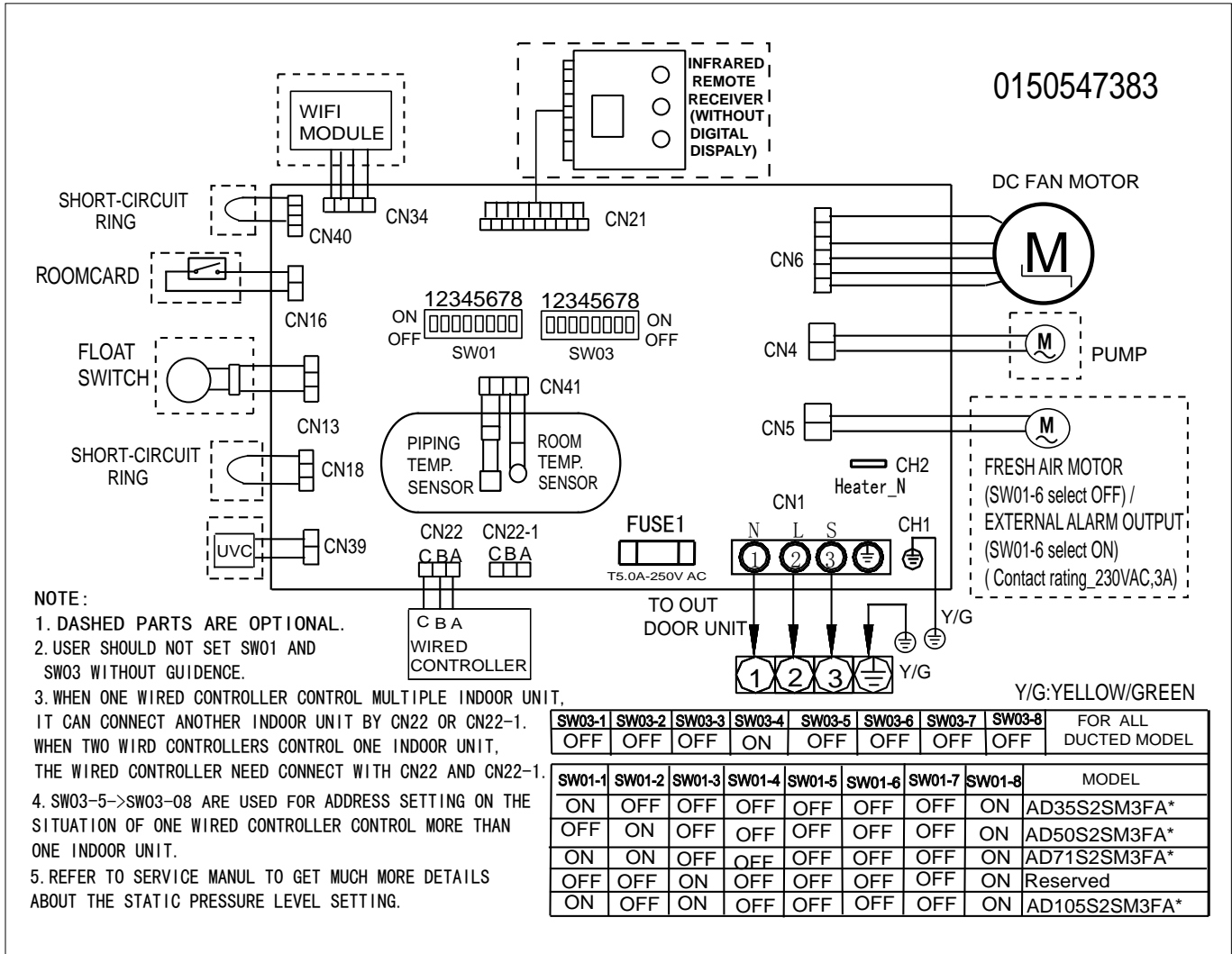

INDOOR UNIT SETTINGS 3.5 KW - 5.0 KW - 7.1 KW - 10.5 KW

SW1 SELECTOR								DESCRIPTION
SW1-1	SW1-2	SW1-3	SW1-4	SW1-5	SW1-6	SW1-7	SW1-8	
OFF	OFF	OFF	---	---	---	---	ON	POWER 2.5 kW
ON	OFF	OFF	---	---	---	---	ON	POWER 3.5 kW
OFF	ON	OFF	---	---	---	---	ON	POWER 5.0 kW
ON	ON	OFF	---	---	---	---	ON	POWER 7.1 kW
OFF	OFF	ON	---	---	---	---	---	POWER 9.0 kW
ON	OFF	ON	---	---	---	---	---	POWER 10.5 kW
OFF	ON	ON	---	---	---	---	---	N.D.
ON	ON	ON	---	---	---	---	---	N.D.
---	---	---	OFF	---	---	---	---	* ROOM CARD (RESTART WITH CONTACT CLOSED)
---	---	---	ON	---	---	---	---	ROOM CARD (STAND BY WITH CONTACT CLOSED)
---	---	---	---	OFF	---	---	---	HEAT PUMP (DEFAULT)
---	---	---	---	ON	---	---	---	COOLING-ONLY
---	---	---	---	---	OFF	---	---	FAN RUNNING SIGNAL ON CN5 (220 VAC) / FRESH AIR
---	---	---	---	---	ON	---	---	ALARM SIGNAL ON CN5 (220 VAC)
---	---	---	---	---	---	OFF	---	FILTER CLEANUP ALARM DISABLED (DEFAULT)
---	---	---	---	---	---	ON	---	FILTER CLEANUP ALERT ENABLED

Selecting the room-card (indoor unit activation board) (BM1-4):

Using switch 4, you can select the operating mode of the room-card, which is a clean contact where components (e.g. window contact) can be applied, so as to be able to manage the switching on and/or off of the indoor units in the system:

- OFF** With open contact the unit stops and with closed contact the unit starts (even if it was previously turned off) in the last mode used. With outdoor contact open, the local controller can turn the unit on/off.
- ON** With open contact the unit stops, and with closed contact the unit is ready to start (it is turned on by remote control). With outdoor contact open, the controller cannot control the unit

SW3 SELECTOR								DESCRIPTION
SW3-1	SW3-2	SW3-3	SW3-4	SW3-5	SW3-6	SW3-7	SW3-8	
OFF	OFF	OFF	---	---	---	---	---	NOT USED (DEFAULT)
---	---	---	OFF	---	---	---	---	SLIM DUCTED LOW PRESSURE
---	---	---	ON	---	---	---	---	DUCTED MEDIUM PRESSURE
---	---	---	---	OFF	OFF	OFF	OFF	MASTER UNIT
---	---	---	---	OFF	OFF	OFF	ON	1 SLAVE UNIT
---	---	---	---	OFF	OFF	ON	OFF	2 SLAVE UNITS
---	---	---	---	OFF	OFF	ON	ON	3 SLAVE UNITS
---	---	---	---	OFF	ON	OFF	OFF	4 SLAVE UNITS
---	---	---	---	OFF	ON	OFF	ON	5 SLAVE UNITS
---	---	---	---	OFF	ON	ON	OFF	6 SLAVE UNITS
---	---	---	---	OFF	ON	ON	ON	7 SLAVE UNITS
---	---	---	---	ON	OFF	OFF	OFF	8 SLAVE UNITS
---	---	---	---	ON	OFF	OFF	ON	9 SLAVE UNITS
---	---	---	---	ON	OFF	ON	OFF	10 SLAVE UNITS
---	---	---	---	ON	OFF	ON	ON	11 SLAVE UNITS
---	---	---	---	ON	ON	OFF	OFF	12 SLAVE UNITS
---	---	---	---	ON	ON	OFF	ON	13 SLAVE UNITS
---	---	---	---	ON	ON	ON	OFF	14 SLAVE UNITS
---	---	---	---	ON	ON	ON	ON	15 SLAVE UNITS

SW3 UNIT ADDRESS FOR WIRED CONTROLLER (REFER TO SELECTORS SW3-5/8)

You can connect up to 16 indoor units using a single wired controller. Each unit must have its respective address:

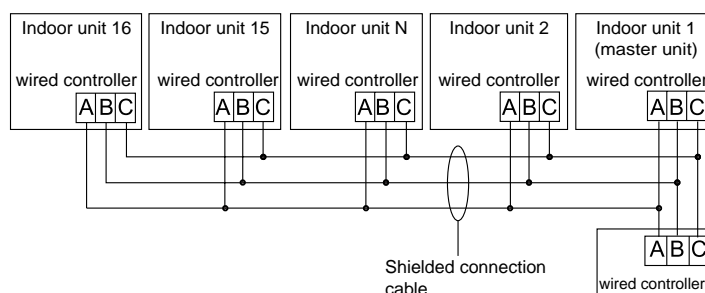

Reading and modifying the static fan pressure (wired controller)

FOR READING/MODIFYING THE STATIC PRESSURE, OPERATE DIRECTLY THROUGH THE WIRED CONTROLLER (E.G. YR E-17)

1. With the controller on and without a screensaver active, press the "Fan" and "Set" keys for 5s at the same time; The static pressure icon flashes and its current value is displayed. Using the keys it is possible to modify the static pressure value. Press the SET key to confirm your modifications.
2. The unit number is displayed in the minutes field in the upper-left corner and the static pressure value in the minutes field of the timer field in the upper right. Press the TIME key to move to the unit number.
3. The unit number is displayed in decimal format between 00 and 15. The static pressure value is displayed in a decimal value between 01 and 04.
4. When modifying, press the ON/OFF key to exit the function and turn the unit on/off without confirming any changes.
5. The static pressure value is not retained when the auto restart function is not set.
6. The static pressure value of "slave" units, when connected in groups, is not modifiable.
7. The current/adjustable static pressure value of the indoor unit can be changed by the wired controller, only for certain models, from the advanced functions menu.

Prevalence setting of Ducted with remote control:

Set the mode: VENTILATION

Set the fan speed: HIGH

Quickly press HEALTH 4+n times, where "n" is the desired static pressure level

The Ducted responds with n+1 beeps, indicating the level set

NB:

Slim Ducted Low Pressure: 4 static pressure levels: 0/10/20/30

Medium Pressure: 10 static pressure levels: 25/37/50/70/90/100/110/120/130/150

High Pressure: 10 static pressure levels: 37/50/70/90/110/130/150/170/190/210

Example:

Slim Ducted Low Pressure AD35S2SS1FA(H)

To set maximum static pressure:

- ventilation mode, high speed; quickly press HEALTH 4+4= 8 TIMES; the Ducted will respond with 4+1=5 BEEPS

IU CIRCUIT DIAGRAM 12.5 KW - 14.0 KW - 16 KW

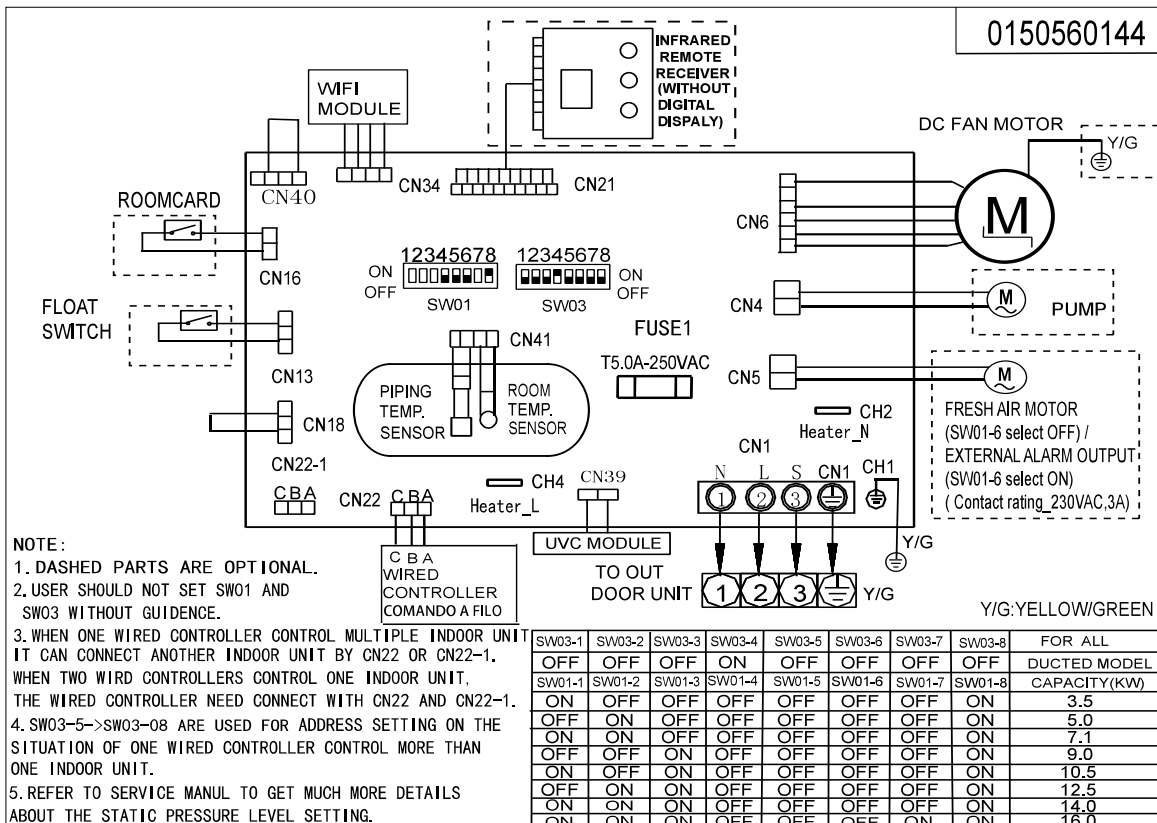

INDOOR UNIT SETTINGS 3.5 KW - 5.0 KW - 7.1 KW - 10.5 KW

SW1 SELECTOR								DESCRIPTION
SW1-1	SW1-2	SW1-3	SW1-4	SW1-5	SW1-6	SW1-7	SW1-8	
OFF	ON	ON	---	---	---	---	---	POWER 12.5 kW
ON	ON	ON	---	---	---	---	---	POWER 14.0 kW / 16.0 kW
---	---	---	OFF	---	---	---	---	* ROOM CARD (RESTART WITH CONTACT CLOSED)
---	---	---	ON	---	---	---	---	ROOM CARD (STAND BY WITH CONTACT CLOSED)
---	---	---	---	OFF	---	---	---	HEAT PUMP (DEFAULT)
---	---	---	---	ON	---	---	---	COOLING-ONLY
---	---	---	---	---	OFF	---	---	FAN RUNNING SIGNAL ON CN5 (220 VAC) / FRESH AIR
---	---	---	---	---	ON	---	---	ALARM SIGNAL ON CN5 (220 VAC)
---	---	---	---	---	---	OFF	---	FILTER CLEANUP ALARM DISABLED (DEFAULT)
---	---	---	---	---	---	ON	---	FILTER CLEANUP ALERT ENABLED
---	---	---	---	---	---	---	OFF	AMERICAN MODELS
---	---	---	---	---	---	---	ON	NON-AMERICAN MODELS

Selecting the room-card (indoor unit activation board) (BM1-4):

Using switch 4, you can select the operating mode of the room-card, which is a clean contact where components (e.g. window contact) can be applied, so as to be able to manage the switching on and/or off of the indoor units in the system:

- OFF** With open contact the unit stops and with closed contact the unit starts (even if it was previously turned off) in the last mode used. With outdoor contact open, the local controller can turn the unit on/off.
- ON** With open contact the unit stops, and with closed contact the unit is ready to start (it is turned on by remote control). With outdoor contact open, the controller cannot control the unit

SW3 SELECTOR								DESCRIPTION
SW3-1	SW3-2	SW3-3	SW3-4	SW3-5	SW3-6	SW3-7	SW3-8	
OFF	OFF	OFF	---	---	---	---	---	NOT USED (DEFAULT)
---	---	---	OFF	---	---	---	---	SLIM DUCTED LOW PRESSURE
---	---	---	ON	---	---	---	---	DUCTED MEDIUM PRESSURE
---	---	---	---	OFF	OFF	OFF	OFF	MASTER UNIT
---	---	---	---	OFF	OFF	OFF	ON	1 SLAVE UNIT
---	---	---	---	OFF	OFF	ON	OFF	2 SLAVE UNITS
---	---	---	---	OFF	OFF	ON	ON	3 SLAVE UNITS
---	---	---	---	OFF	ON	OFF	OFF	4 SLAVE UNITS
---	---	---	---	OFF	ON	OFF	ON	5 SLAVE UNITS
---	---	---	---	OFF	ON	ON	OFF	6 SLAVE UNITS
---	---	---	---	OFF	ON	ON	ON	7 SLAVE UNITS
---	---	---	---	ON	OFF	OFF	OFF	8 SLAVE UNITS
---	---	---	---	ON	OFF	OFF	ON	9 SLAVE UNITS
---	---	---	---	ON	OFF	ON	OFF	10 SLAVE UNITS
---	---	---	---	ON	OFF	ON	ON	11 SLAVE UNITS
---	---	---	---	ON	ON	OFF	OFF	12 SLAVE UNITS
---	---	---	---	ON	ON	ON	OFF	13 SLAVE UNITS
---	---	---	---	ON	ON	ON	ON	14 SLAVE UNITS
---	---	---	---	ON	ON	ON	ON	15 SLAVE UNITS

SW3 UNIT ADDRESS FOR WIRED CONTROLLER (REFER TO SELECTORS SW3-5/8)

You can connect up to 16 indoor units using a single wired controller. Each unit must have its respective address:

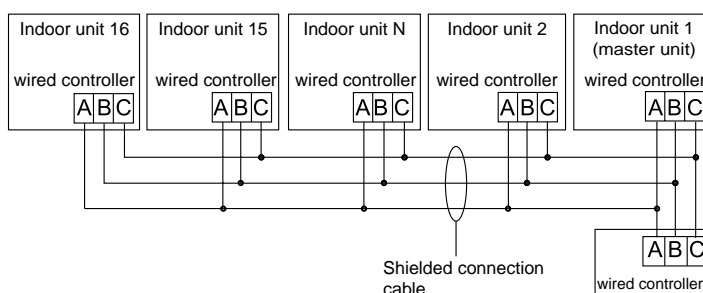

Reading and modifying the static fan pressure (wired controller)

FOR READING/MODIFYING THE STATIC PRESSURE, OPERATE DIRECTLY THROUGH THE WIRED CONTROLLER (E.G. YR E-17)

1. With the controller on and without a screensaver active, press the "Fan" and "Set" keys for 5s at the same time; The static pressure icon flashes and its current value is displayed. Using the keys it is possible to modify the static pressure value. Press the SET key to confirm your modifications.
2. The unit number is displayed in the minutes field in the upper-left corner and the static pressure value in the minutes field of the timer field in the upper right. Press the TIME key to move to the unit number.
3. The unit number is displayed in decimal format between 00 and 15. The static pressure value is displayed in a decimal value between 01 and 04.
4. When modifying, press the ON/OFF key to exit the function and turn the unit on/off without confirming any changes.
5. The static pressure value is not retained when the auto restart function is not set.
6. The static pressure value of "slave" units, when connected in groups, is not modifiable.
7. The current/adjustable static pressure value of the indoor unit can be changed by the wired controller, only for certain models, from the advanced functions menu.

Prevalence setting of Ducted with remote control:

Set the mode: VENTILATION

Set the fan speed: HIGH

Quickly press HEALTH 4+n times, where "n" is the desired static pressure level

The Ducted responds with n+1 beeps, indicating the level set

NB:

Slim Ducted Low Pressure: 4 static pressure levels: 0/10/20/30

Medium Pressure: 10 static pressure levels: 25/37/50/70/90/100/110/120/130/150

High Pressure: 10 static pressure levels: 37/50/70/90/110/130/150/170/190/210

Example:

Slim Ducted Low Pressure AD35S2SS1FA

To set maximum static pressure:

- ventilation mode, high speed; quickly press HEALTH 4+4= 8 TIMES; the Ducted will respond with 4+1=5 BEEPs

SW2 SELECTOR				
SW2-1	SW2-2	SW2-3	SW2-4	ADDRESS OF WIRED CONTROLLER
OFF	OFF	OFF	OFF	Master unit
OFF	OFF	OFF	ON	Slave unit 1
OFF	OFF	ON	OFF	Slave unit 2
---	---	---	---	Address No. ---
ON	ON	ON	ON	Address No. 16

Reading and modifying the static fan pressure (wired controller)

FOR READING/MODIFYING THE STATIC PRESSURE, OPERATE DIRECTLY THROUGH THE WIRED CONTROLLER

1. With the controller on and without a screensaver active, press the "Fan" and "Set" keys for 5s at the same time; The static pressure icon flashes and its current value is displayed. Using the keys it is possible to modify the static pressure value. Press the SET key to confirm your modifications.
2. The unit number is displayed in the minutes field in the upper-left corner and the static pressure value in the minutes field of the timer field in the upper right. Press the TIME key to move to the unit number.
3. The unit number is displayed in decimal format between 00 and 15. The static pressure value is displayed in a decimal value between 01 and 04.
4. When modifying, press the ON/OFF key to exit the function and turn the unit on/off without confirming any changes.
5. The static pressure value is not retained when the auto restart function is not set.
6. The static pressure value of "slave" units, when connected in groups, is not modifiable.
7. The current/adjustable static pressure value of the indoor unit can be changed by the wired controller, only for certain models, from the advanced functions menu.

Prevalence setting of Ducted with remote control:

Set the mode: VENTILATION

Set the fan speed: HIGH

Quickly press HEALTH 4+n times, where "n" is the desired static pressure level

The Ducted responds with n+1 beeps, indicating the level set

NB:

Slim Ducted Low Pressure: 4 static pressure levels: 0/10/20/30
 Medium Pressure: 10 static pressure levels: 25/37/50/70/90/100/110/120/130/150
 High Pressure: 10 static pressure levels: 37/50/70/90/110/130/150/170/190/210

Example:

Slim Ducted Low Pressure AD35S2SM3FA(H)
 To set maximum static pressure:
 - ventilation mode, high speed; quickly press HEALTH 4+4= 8 TIMES; the Ducted will respond with 4+1=5 BEEPS

INDOOR UNIT SETTINGS 16 KW

Selector Bank (SW1)

SW1 SELECTOR								Description
Power			Room card	Mode: heating / cooling	Fresh air / failure alarms	Time filters	Region	
SW1-1	SW1-2	SW1-3	SW1-4	SW1-5	SW1-6	SW1-7	SW1-8	
ON	ON	ON	---	---	---	---	---	AD160S2SM3FA(H)
---	---	---	OFF	---	---	---	---	*Room card disabled
---	---	---	ON	---	---	---	---	Room card with restart
---	---	---	---	OFF	---	---	---	Heat pump (default)
---	---	---	---	ON	---	---	---	Cooling-only
---	---	---	---	---	OFF	---	---	Fan running signal on cn5 (220 Vac) / Fresh air
---	---	---	---	---	ON	---	---	Alarm signal on cn5 (220 Vac)
---	---	---	---	---	---	OFF	---	Filter hours counter off (default)
---	---	---	---	---	---	ON	---	Filter hours counter enabled
---	---	---	---	---	---	---	ON	Europe market

Selecting the room-card (indoor unit activation board) (BM1-4):

Using switch 4, you can select the operating mode of the room-card, which is a clean contact where components (e.g. window contact) can be applied, so as to be able to manage the switching on and/or off of the indoor units in the system:

OFF With open contact the unit stops and with closed contact the unit starts (even if it was previously turned off) in the last mode used. With outdoor contact open, the local controller can turn the unit on/off.

ON With open contact the unit stops, and with closed contact the unit is ready to start (it is turned on by remote control). With outdoor contact open, the controller cannot control the unit

Selector Bank SW3

SW3								Description
SW3-1	SW3-2	SW3-3	SW3-4	SW3-5	SW3-6	SW3-7	SW3-8	
OFF	---	---	---	---	---	---	---	1 deflector motor / no deflector motor (default)
ON	---	---	---	---	---	---	---	2 deflector motors
---	OFF	OFF	---	---	---	---	---	N.D.
---	---	---	OFF	---	---	---	---	static pressure adjustment 4 steps
---	---	---	ON	---	---	---	---	static pressure adjustment 10 steps (default)

Selector bank BM3

Addresses for communication of multiple units with a single wired controller.

BM3								Description
BM3-1	BM3-2	BM3-3	BM3-4	BM3-5	BM3-6	BM3-7	BM3-8	
---	---	---	---	OFF	OFF	OFF	OFF	Master Unit
---	---	---	---	OFF	OFF	OFF	ON	Unit SLAVE 1
---	---	---	---	OFF	OFF	ON	OFF	Unit SLAVE 2
---	---	---	---	OFF	OFF	ON	ON	Unit SLAVE 3
---	---	---	---	---	---	---	---	Unit SLAVE --
---	---	---	---	ON	ON	ON	ON	Unit SLAVE 15

OUTDOOR UNITS

3S Tank	114
Supermatch Mono R32	116
Supermatch Multi R32	129
Supermatch Mono R410A	139
Maxi Split R32	146

Indoor-outdoor units
AN100S2ST1FA
AS35S2SJ1FA-3

INDOOR UNIT			AN100S2ST1FA	AS35S2SJ1FA-3
Indoor unit technical data				
Liquid pipe Ø		mm (inch)	6,35 (1/4)	6,35 (1/4)
Gas pipe Ø		mm	9,52 (3/8)	9,52 (3/8)
Power Supply		Ph/V/Hz	1/220-240/50/60	1/220-240/50/60
Net dimensions	WxDxH	mm	470x560x1110	520x610x1650
Net / gross weight		kg	45,0 (62,0)	70,0 (88,0)
Heating Time average Climate		h:mm	2:20/ 2:30	3:10/ 3:20
Heating Time warm Climate		h:mm	2:00/ 2:10	2:50/ 3:00
Seasonal efficiency			M	L

OUTDOOR UNIT PRINTED CIRCUIT BOARD CONNECTOR

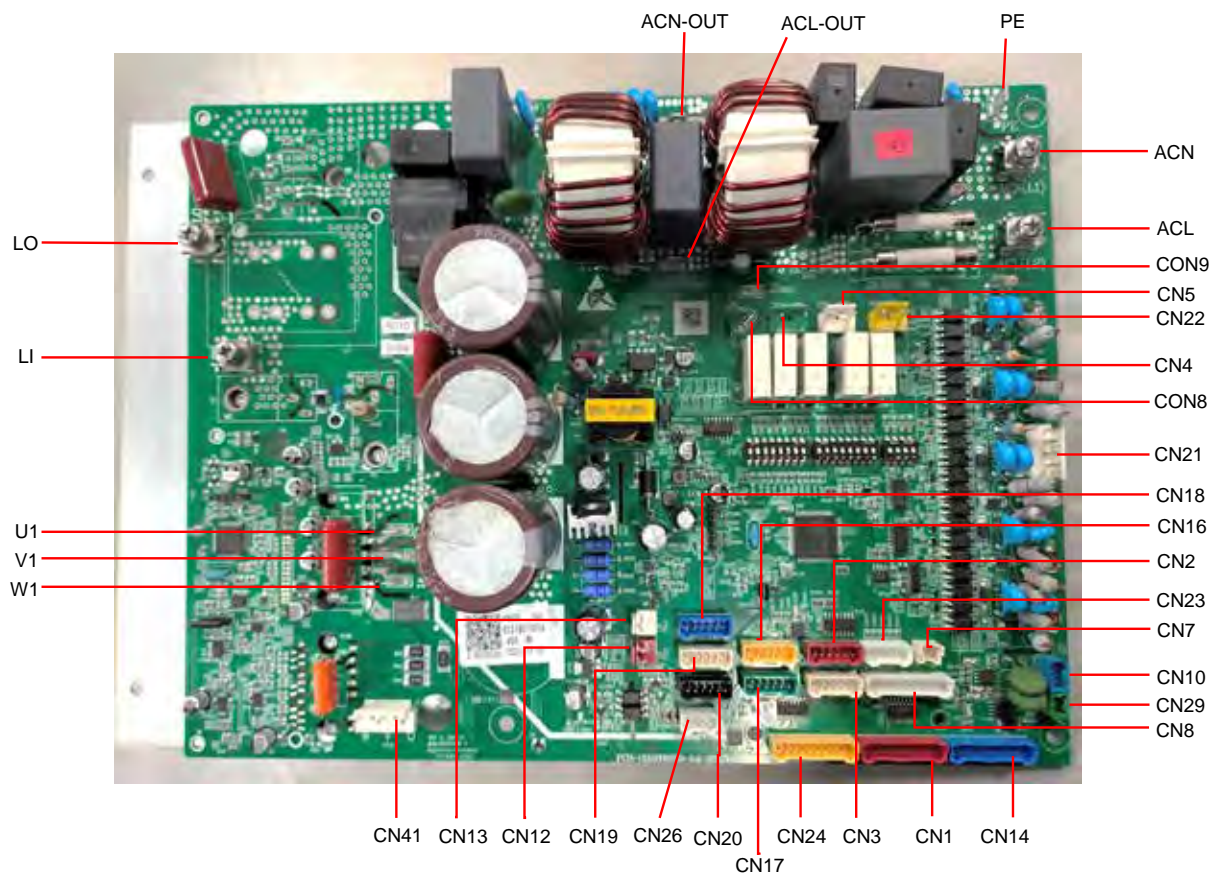

CONNECTOR	CONNECTED TO	DESCRIPTION
ACN	Power supply terminal block of the outdoor unit	Unit AC power supply input
ACL		
PE	Unit metal shell	Earth path of the filter circuit Y capacitor
LO	Reactor	Reactor for power factor correction
LI		
U1	Compressor	Power supply for the compressor
V1		
W1		
CN1	Sensor of TC1	Indoor gas pipe coil temperature sensor for indoor unit or tank unit
CN2	PMV-RE1	Pulse Modulated Valve of EV
CN3	PMV-RE2	Pulse Modulated Valve of CO
CN4	Base pan heater	Heater for base pan de-icing
CN5	4 way valve	Switch valve for heat pump or defrost
CN7	None	Not use, reserved
CN8	CN2 of the display board	Power supply and dual 7-segment LED control signals of the display board
CN10	None	Not use, reserved
CN12	High pressure switch	Switch for system high pressure protection
CN13	Low pressure switch	Switch for system low pressure protection
CN14	Tc+Ts+Ta+Td+Te sensor	Tc: Outdoor coil temperature sensor Ts: Compressor suction temperature sensor Ta: Outdoor ambient temperature sensor Td: Compressor discharge temperature sensor Te: Outdoor condenser defrosting coil temperature sensor
CN16	PMV-A	Pulse Modulated Valve for indoor unit A
CN17	PMV-B	Pulse Modulated Valve for indoor unit B
CN18	PMV-C	Pulse Modulated Valve for indoor unit C
CN19	PMV-D	Pulse Modulated Valve for indoor unit D
CN20	PMV-E	Pulse Modulated Valve for ATW tank unit
CN21	Terminal number 3 of the outdoor& indoor unit connection terminal block	Communication signals for air conditioner indoor unit and outdoor unit
CN22	SV-ATW	Solenoid valve for tank refrigerant flow ON/OFF control
CN23	CN3 of the display board	Signal path of the DIP Switch which is on display board
CN24	Sensor of TC2	Indoor liquid pipe coil temperature sensor for indoor unit or tank unit
CN26	None	Not use, reserved
CN29	Communication block for ATW-tank unit	Communication signals for ATW-tank unit and outdoor unit
CN41	DC fan motor	Power supply for the fan motor
CON8	Crank case heater	Crank case heater for compressor, optional, some models without
CON9		

Outdoor units

1U25S2SM1FA-2 2.5 kW
1U35S2SM1FA-2 3.5 kW
1U42S2SM1FA 4.2 kW
1U71S2SR2FA 7.1 kW
1U50S2SJ2FA-2 5.0 kW

1U105S2SS1FB 10.5 kW (three-phase)
1U105S2SS2FA 10.5 kW (single-phase)
1U125S2SN2FA 12.5 kW (single-phase)
1U125S2SN2FB (three-phase)
1U140S2SP2FA (single-phase)

1U140S2SP2FB (three-phase)
1U140S2SN1FA 14.0 kW (single-phase)
1U140S2SN1FB 14.0 kW (three-phase)
1U160S2SP1FB 16.0 kW

OUTDOOR UNIT		1U25S2SM1FA-2	1U35S2SM1FA-2	1U42S2SM1FA	1U50S2SJ2FA-2	1U71S2SR2FA
Outdoor unit technical data						
Liquid pipe Ø	mm	6.35	6.35	6.35	6.35	9.52
Gas pipe Ø	mm	9.52	9.52	9.52	12.7	15.88
Standard pipe length without additional refrigerant charge	7	7	7	7	7	7
Maximum pipe length	m	20	20	20	25	50
Maximum IU - OU height difference	m	10	10	10	15	30
Refrigerant charge in the factory	kg	0.65	0.94	0.94	1.1	1.3
Equivalent tons of CO ²	tCO ₂ EQ	0.44	0.63	0.63	0.74	0.87
Additional refrigerant charge beyond standard length	g/m	20	20	20	20	45
Dimensions (WxDxH)	mm	800x275x553	800x275x553	800x275x553	820x338x614	890x353x697
Net weight	kg	29	31.5	31.5	35.7	45
Power Supply	V-Ph-Hz	1/220~240/50	1/220~240/50	1/220~240/50	1/220~240/50	1/220~240/50
Outdoor unit power cable	mm ²	3G1.5	3G1.5	3G1.5	3G2.5	3G2.5
Outdoor unit - indoor unit cable	mm ²	4G1.5	4G1.5	4G1.5	4G1.5	4G1.5

OUTDOOR UNIT		1U105S2SS1FB	1U105S2SS2FA	1U125S2SN2FA	1U125S2SN2FB	1U140S2SP2FA
Outdoor unit technical data						
Liquid pipe Ø	mm	9.52	9.52	9.52	9.52	9.52
Gas pipe Ø	mm	15.88	15.88	15.88	15.88	15.88
Standard pipe length without additional refrigerant charge	7	30	30	30	30	30
Maximum pipe length	m	50	50	50	50	70
Maximum IU - OU height difference	m	30	30	30	30	30
Refrigerant charge in the factory	kg	1.5	1.5	2	2	2.9
Equivalent tons of CO ²	tCO ₂ EQ	0.87	0.87	1.3	1.3	1.95
Additional refrigerant charge beyond standard length	g/m	45	45	45	45	45
Dimensions (WxDxH)	mm	920x372x760	920x372x760	950x370x965	950x370x965	950x370x1350
Net weight	kg	60	60	82	83	105
Power Supply	V-Ph-Hz	380~400-3N-50	1/220~240/50/60	1/220~240/50/60	3/380~415/50/60	1/220~240/50/60
Outdoor unit power cable	mm ²	3G4	3G4	3G4	5G2.5	5G2.5
Outdoor unit - indoor unit cable	mm ²	4G1.5	4G1.5	4G1.5	4G1.5	4G1.5

OUTDOOR UNIT		1U140S2SP2FB	1U140S2SN1FA	1U140S2SN1FB	1U160S2SP1FB
Outdoor unit technical data					
Liquid pipe Ø	mm	9.52	9.52	9.52	9.52
Gas pipe Ø	mm	15.88	15.88	15.88	19.05
Standard pipe length without additional refrigerant charge	7	30	30	30	30
Maximum pipe length	m	70	70	70	70
Maximum IU - OU height difference	m	30	30	30	30
Refrigerant charge in the factory	kg	3.5	2.3	2.3	3.2
Equivalent tons of CO ²	tCO ₂ EQ	2.36	1.55	1.55	2.36
Additional refrigerant charge beyond standard length	g/m	45	45	45	45
Dimensions (WxDxH)	mm	950x370x1350	950x370x965	950x370x965	950x370x1350
Net weight	kg	101	84	85	101
Power Supply	V-Ph-Hz	3/380~415/50/60	1/220~240/50/60	3/380~415/50/60	3/380~415/50/60
Outdoor unit power cable	mm ²	5G2.5	5G2.5	5G2.5	5G2.5
Outdoor unit - indoor unit cable	mm ²	4G1.5	4G1.5	4G1.5	4G1.5

MONO DIAGNOSTICS

If the indoor unit is a wall-mounted split, refer to the alarm list on **page 30 - 31**.

If the indoor unit is a console / cassette / ducted / ceiling-floor convertible, go to **page 28 - 29**.

OU CIRCUIT DIAGRAM 2.5 KW - 3.5 KW

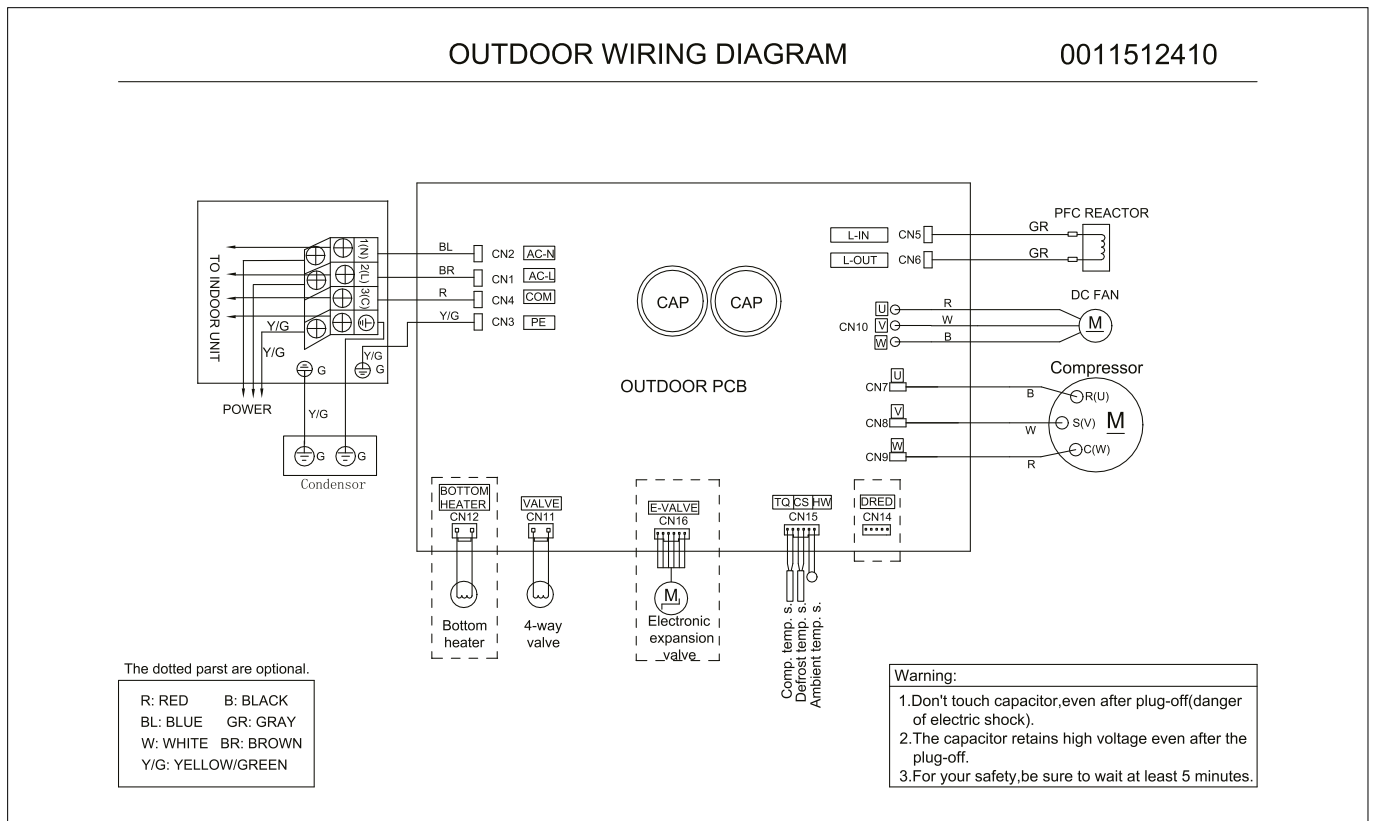

OU CIRCUIT DIAGRAM 4.2 KW

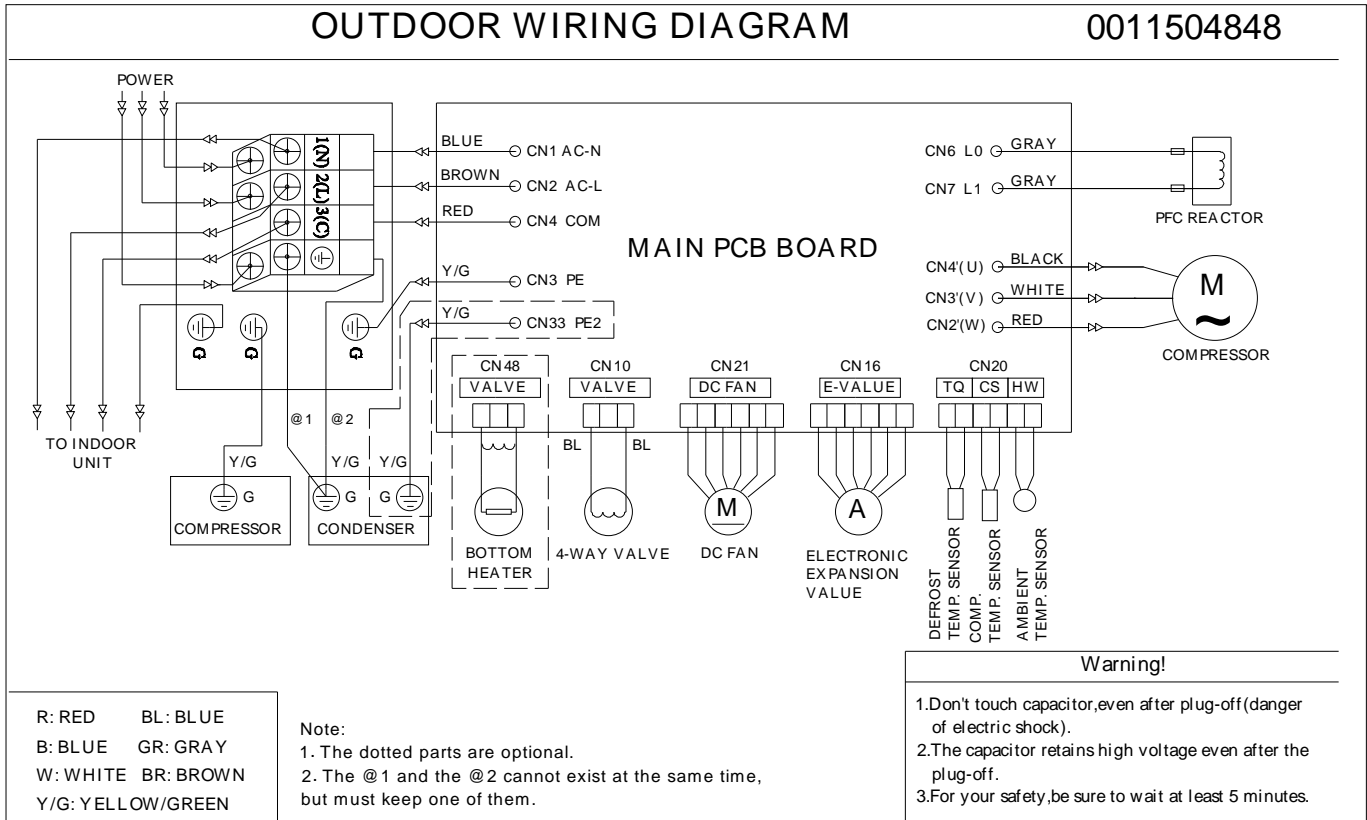

OU WIRING DIAGRAM 5 KW (1U50S2S2J2FA-2)

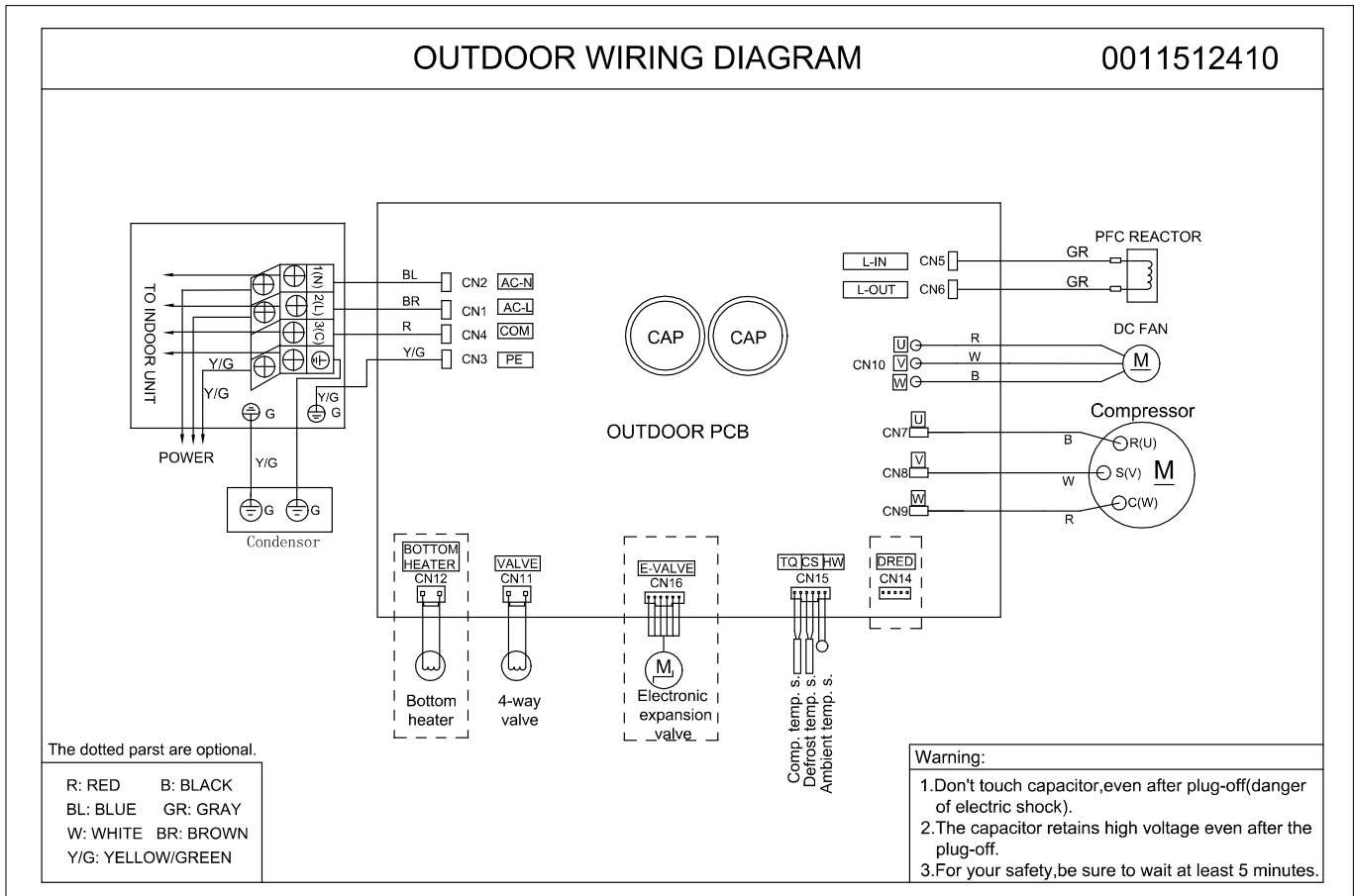

OU CIRCUIT DIAGRAM 10.5 KW SINGLE-PHASE (1U105S2SS2FA)

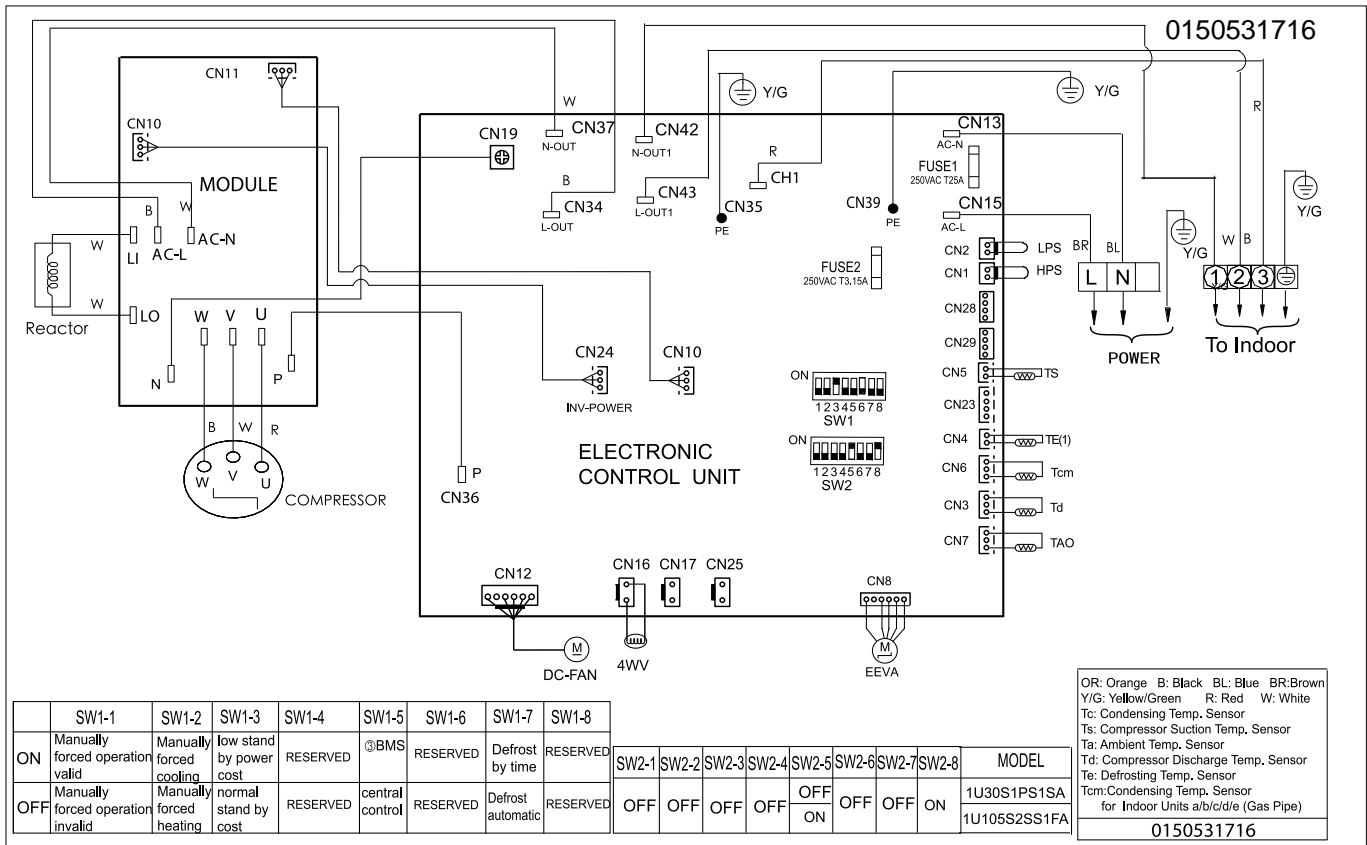

OU SETTINGS 10.5 KW SINGLE-PHASE (1U105S2SS2FA)

SW1 SELECTOR								DESCRIPTION
SW1-1	SW1-2	SW1-3	SW1-4	SW1-5	SW1-6	SW1-7	SW1-8	
ON	---	---	---	---	---	---	---	Forced mode enabled
OFF	---	---	---	---	---	---	---	Force mode disabled
---	ON	---	---	---	---	---	---	Forced cooling
---	OFF	---	---	---	---	---	---	Forced heat pump
---	---	ON	---	---	---	---	---	Low consumption stand by
---	---	OFF	---	---	---	---	---	Normal consumption stand by
---	---	---	ON	---	---	---	---	N.D.
---	---	---	OFF	---	---	---	---	N.D. (DEFAULT)
---	---	---	---	ON	---	---	---	Connection to BMS system
---	---	---	---	OFF	---	---	---	Connection to centralized controller
---	---	---	---	---	ON	---	---	N.D.
---	---	---	---	---	OFF	---	---	N.D. (DEFAULT)
---	---	---	---	---	---	ON	---	Timed defrosting
---	---	---	---	---	---	OFF	---	Automatic defrosting
---	---	---	---	---	---	---	ON	N.D.
---	---	---	---	---	---	---	OFF	N.D. (DEFAULT)

SW2 SELECTOR								DESCRIPTION
SW2-1	SW2-2	SW2-3	SW2-4	SW2-5	SW2-6	SW2-7	SW2-8	
OFF	OFF	OFF	OFF	ON	OFF	OFF	ON	1U105S2SS1FA
OFF	OFF	OFF	OFF	ON	OFF	OFF	ON	1U105S2SS2FA

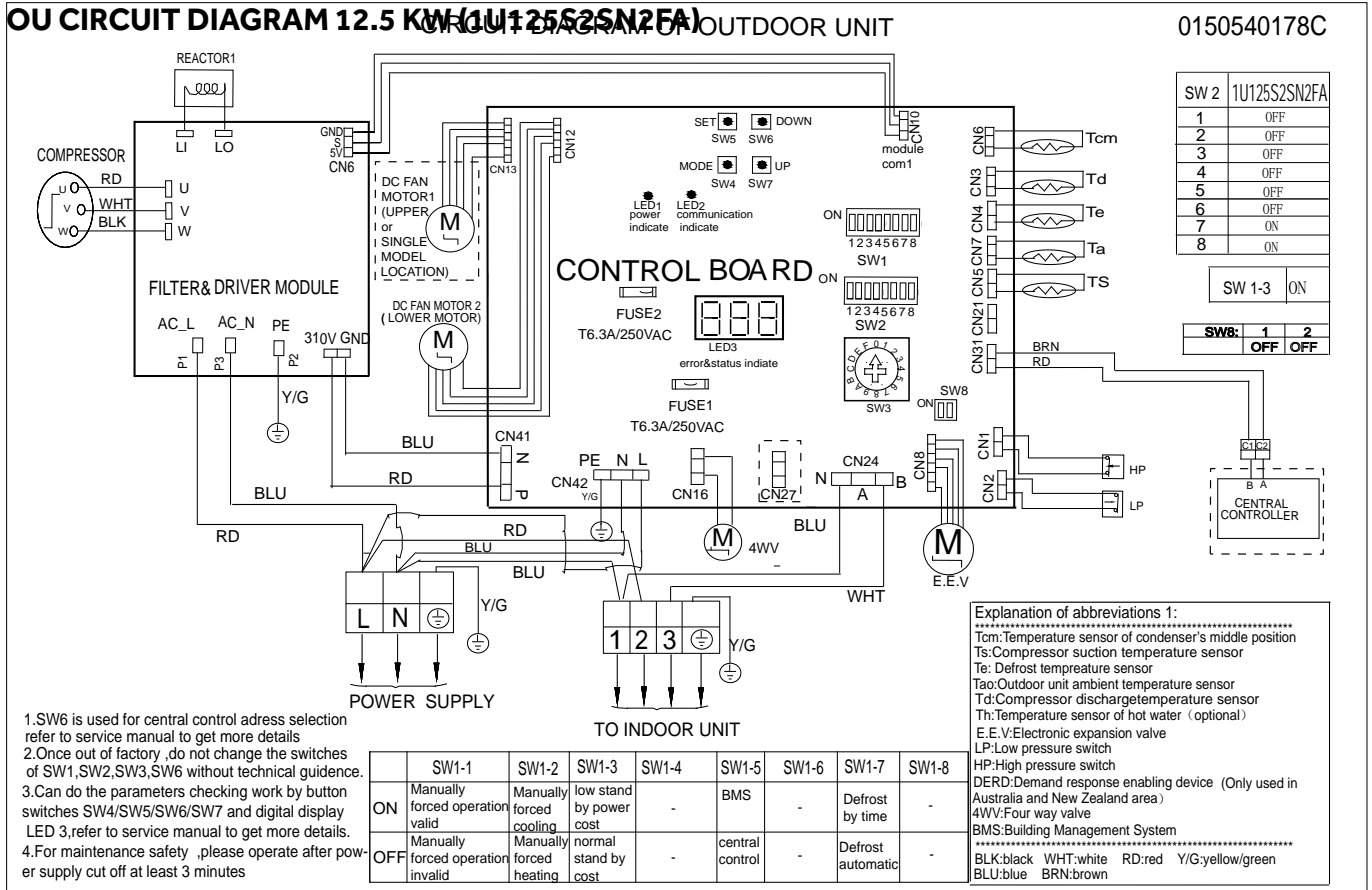

OU SETTINGS 12.5 KW (1U125S2SN2FA)

SW1 SELECTOR								DESCRIPTION
SW1-1	SW1-2	SW1-3	SW1-4	SW1-5	SW1-6	SW1-7	SW1-8	
ON	---	---	---	---	---	---	---	Forced mode enabled
OFF	---	---	---	---	---	---	---	Force mode disabled
---	ON	---	---	---	---	---	---	Forced cooling
---	OFF	---	---	---	---	---	---	Forced heat pump
---	---	ON	---	---	---	---	---	Low consumption stand by
---	---	OFF	---	---	---	---	---	Normal consumption stand by
---	---	---	ON	---	---	---	---	N.D.
---	---	---	OFF	---	---	---	---	N.D. (DEFAULT)
---	---	---	---	ON	---	---	---	Connection to BMS system
---	---	---	---	OFF	---	---	---	Connection to centralized controller
---	---	---	---	---	ON	---	---	N.D.
---	---	---	---	---	OFF	---	---	N.D. (DEFAULT)
---	---	---	---	---	---	ON	---	Timed defrosting
---	---	---	---	---	---	OFF	---	Automatic defrosting
---	---	---	---	---	---	---	ON	N.D.
---	---	---	---	---	---	---	OFF	N.D. (DEFAULT)

SW2 SELECTOR								DESCRIPTION
SW2-1	SW2-2	SW2-3	SW2-4	SW2-5	SW2-6	SW2-7	SW2-8	
OFF	OFF	OFF	OFF	OFF	ON	ON	ON	1U140S2SN1FA
OFF	OFF	OFF	OFF	ON	OFF	OFF	OFF	1U140S2SN1FB
OFF	OFF	OFF	OFF	ON	ON	OFF	OFF	1U160S2SN1FB
OFF	OFF	OFF	OFF	OFF	OFF	ON	ON	1U125S2SN2FA
OFF	OFF	OFF	OFF	OFF	ON	OFF	OFF	1U125S2SN2FB
OFF	OFF	OFF	OFF	ON	OFF	ON	OFF	1U140S2SP2FB

SW3 SELECTOR	
ROTARY	DESCRIPTION
ON	1U125S2SN2FA

SW6 SELECTOR Address to centralized controller / BMS								
SW6-1	SW6-2	SW6-3	SW6-4	SW6-5	SW6-6	SW6-7	SW6-8	DESCRIPTION
OFF	OFF	OFF	OFF	OFF	OFF	OFF	OFF	Address No. 1
OFF	OFF	OFF	OFF	OFF	OFF	OFF	ON	Address No. 2
OFF	OFF	OFF	OFF	OFF	OFF	ON	OFF	Address No. 3
OFF	OFF	OFF	OFF	OFF	OFF	ON	ON	Address No. 4
OFF	OFF	OFF	OFF	OFF	ON	OFF	OFF	Address No. 5
---	---	---	---	---	---	---	---	Address No. --
ON	ON	ON	ON	ON	ON	ON	ON	Address No. 128

SW7 SELECTOR		
SW8-1	SW2-2	DESCRIPTION
OFF	OFF	N.D. - DEFAULT

OU CIRCUIT DIAGRAM 14 KW single-phase (1U140S2SP2FA)

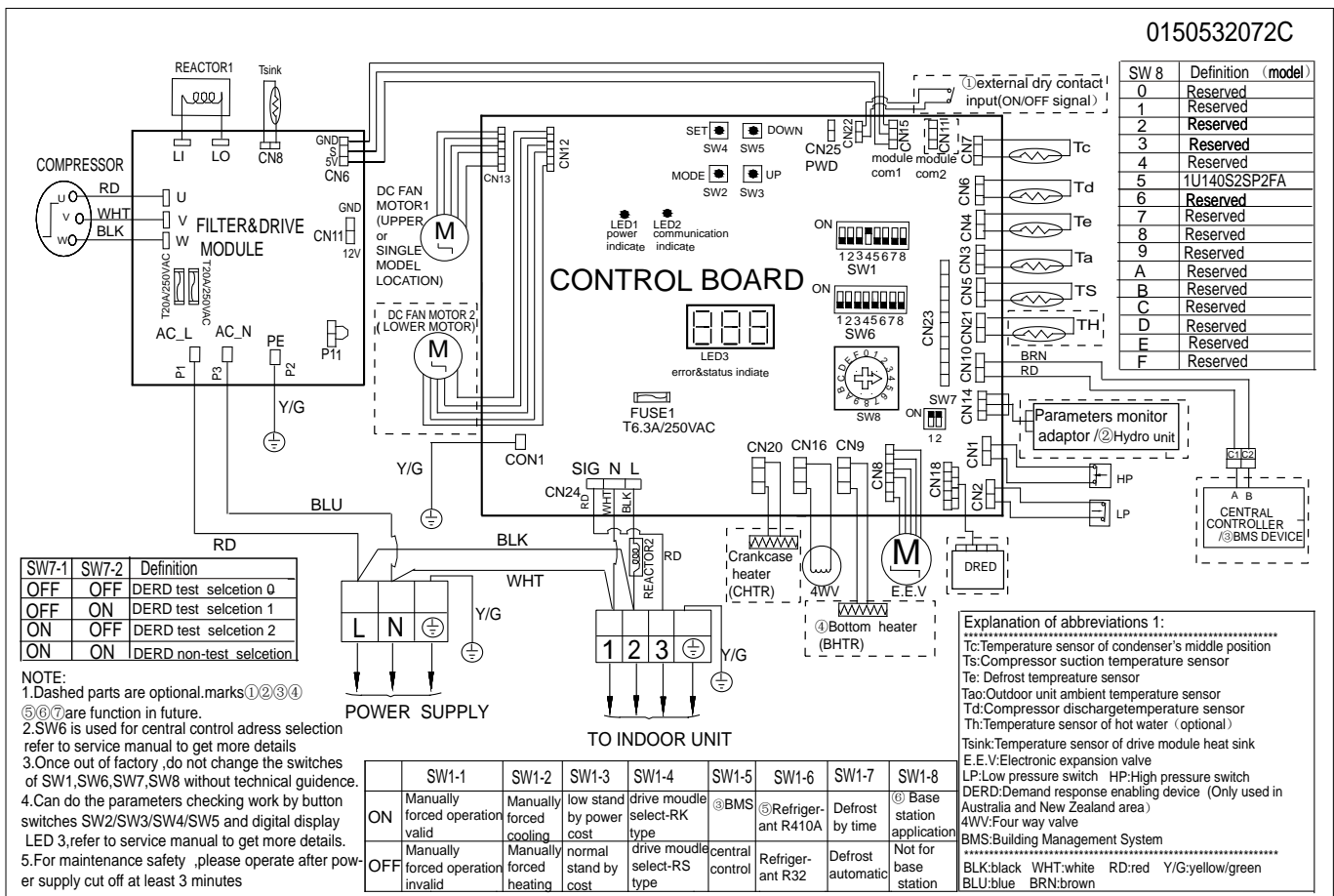

OU SETTINGS 14 KW (1U140S2SP2FA)

SW1 SELECTOR								
SW1-1	SW1-2	SW1-3	SW1-4	SW1-5	SW1-6	SW1-7	SW1-8	DESCRIPTION
ON	---	---	---	---	---	---	---	Forced mode enabled
OFF	---	---	---	---	---	---	---	Force mode disabled
---	ON	---	---	---	---	---	---	Forced cooling
---	OFF	---	---	---	---	---	---	Forced heat pump
---	---	ON	---	---	---	---	---	Low consumption stand by
---	---	OFF	---	---	---	---	---	Normal consumption stand by
---	---	---	ON	---	---	---	---	RK series power module - DEFAULT
---	---	---	OFF	---	---	---	---	RS series power module
---	---	---	---	ON	---	---	---	Connection to BMS system
---	---	---	---	OFF	---	---	---	Connection to centralized controller
---	---	---	---	---	ON	---	---	R410A refrigerant
---	---	---	---	---	OFF	---	---	R32 refrigerant - DEFAULT
---	---	---	---	---	---	ON	---	Timed defrosting
---	---	---	---	---	---	OFF	---	Automatic defrosting
---	---	---	---	---	---	---	ON	N.D.
---	---	---	---	---	---	---	OFF	N.D. (DEFAULT)

SW6 SELECTOR Address to centralized controller / BMS								
SW6-1	SW6-2	SW6-3	SW6-4	SW6-5	SW6-6	SW6-7	SW6-8	DESCRIPTION
OFF	OFF	OFF	OFF	OFF	OFF	OFF	OFF	Address No. 1
OFF	OFF	OFF	OFF	OFF	OFF	OFF	ON	Address No. 2
OFF	OFF	OFF	OFF	OFF	OFF	ON	OFF	Address No. 3
OFF	OFF	OFF	OFF	OFF	OFF	ON	ON	Address No. 4
OFF	OFF	OFF	OFF	OFF	ON	OFF	OFF	Address No. 5
---	---	---	---	---	---	---	---	Address No. --
ON	ON	ON	ON	ON	ON	ON	ON	Address No. 128

SW7 SELECTOR		
SW7-1	SW7-2	DESCRIPTION
ON	ON	N.D. - DEFAULT

SW8 SELECTOR	
ROTARY	DESCRIPTION
4	1U125S2SN1FA
5	1U140S2SP1FA / 1U140S2SP2FA

OU CIRCUIT DIAGRAM 14 KW single-phase (1U140S2SN1FA)

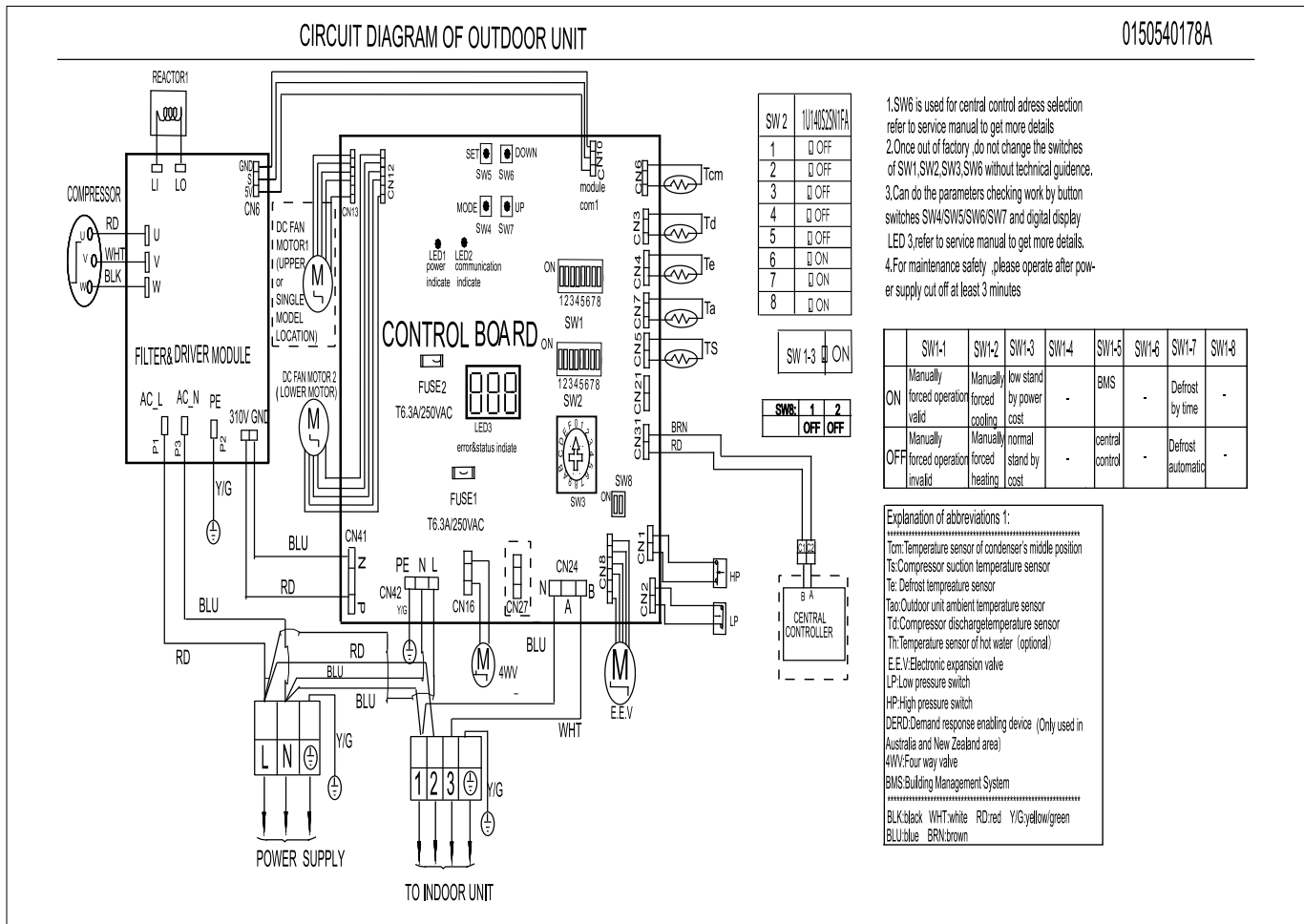

OU SETTINGS 14 KW single-phase (1U140S2SN1FA)

SELECTOR BANK SW1								DESCRIPTION
SW1-1	SW1-2	SW1-3	SW1-4	SW1-5	SW1-6	SW1-7	SW1-8	
OFF	---	---	---	---	---	---	---	FORCED DISABLING
ON	---	---	---	---	---	---	---	FORCED ENABLING
---	OFF	---	---	---	---	---	---	FORCED COOLING (SE SW1-1 ON)
---	ON	---	---	---	---	---	---	FORCED HEATING (SE SW1-1 ON)
---	---	ON	---	---	---	---	---	LOW CONSUMPTION IN STAND BY (DEFAULT)
---	---	OFF	---	---	---	---	---	NORMAL CONSUMPTION IN STAND BY
---	---	---	OFF	---	---	---	---	N.D.
---	---	---	---	ON	---	---	---	CONTROL VIA BMS
---	---	---	---	OFF	---	---	---	CONTROL VIA CENTRALISED CONTROLLER
---	---	---	---	---	OFF	---	---	N.D.
---	---	---	---	---	---	ON	---	DEFROSTING UNDER SPECIFIC CONDITIONS
---	---	---	---	---	---	OFF	---	AUTOMATIC DEFROSTING (DEFAULT)
---	---	---	---	---	---	---	ON	SILENT MODE ENABLED
---	---	---	---	---	---	---	OFF	SILENT MODE DISABLED (DEFAULT)

SELECTOR BANK SW2								DESCRIPTION
SW2-1	SW2-2	SW2-3	SW2-4	SW2-5	SW2-6	SW2-7	SW2-8	
OFF	OFF	OFF	OFF	OFF	ON	ON	ON	1U140S2SN1FA
OFF	OFF	OFF	OFF	ON	OFF	OFF	OFF	1U140S2SN1FB
OFF	OFF	OFF	OFF	ON	ON	OFF	OFF	1U160S2SP1FB

SELECTOR SW3	
SW3	DESCRIPTION
0	DEFAULT

SELECTOR BANK SW8		
SW8-1	SW8-2	DESCRIPTION
OFF	OFF	DEFAULT

OU 10.5 KW three-phase (1U105S2SS1FB)

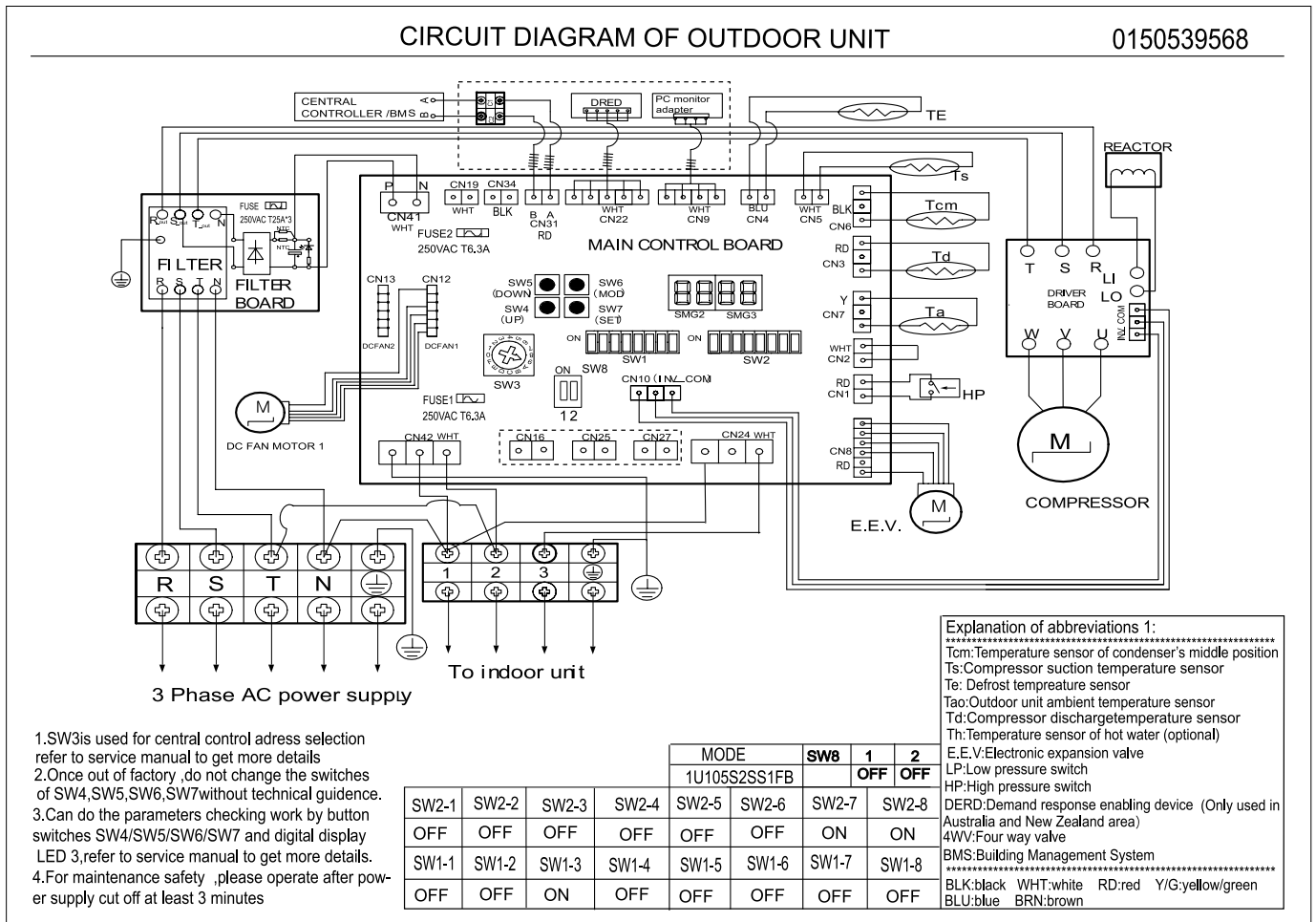

OU SETTINGS 10.5 KW three-phase (1U105S2SS1FB)

SELECTOR BANK SW1								DESCRIPTION
SW1-1	SW1-2	SW1-3	SW1-4	SW1-5	SW1-6	SW1-7	SW1-8	
OFF	---	---	---	---	---	---	---	FORCED DISABLING
ON	---	---	---	---	---	---	---	FORCED ENABLING
---	OFF	---	---	---	---	---	---	FORCED COOLING (SE SW1-1 ON)
---	ON	---	---	---	---	---	---	FORCED HEATING (SE SW1-1 ON)
---	---	ON	---	---	---	---	---	LOW CONSUMPTION IN STAND BY (DEFAULT)
---	---	OFF	---	---	---	---	---	NORMAL CONSUMPTION IN STAND BY
---	---	---	OFF	---	---	---	---	N.D.
---	---	---	---	ON	---	---	---	CONTROL VIA BMS
---	---	---	---	OFF	---	---	---	CONTROL VIA CENTRALISED CONTROLLER
---	---	---	---	---	OFF	---	---	N.D.
---	---	---	---	---	---	ON	---	DEFROSTING UNDER SPECIFIC CONDITIONS
---	---	---	---	---	---	OFF	---	AUTOMATIC DEFROSTING (DEFAULT)
---	---	---	---	---	---	---	ON	SILENT MODE ENABLED
---	---	---	---	---	---	---	OFF	SILENT MODE DISABLED (DEFAULT)

SELECTOR BANK SW2								DESCRIPTION
SW2-1	SW2-2	SW2-3	SW2-4	SW2-5	SW2-6	SW2-7	SW2-8	
OFF	OFF	OFF	OFF	ON	OFF	ON	ON	1U105S2SS1FB

SELECTOR SW3	
SW3	DESCRIPTION
0	DEFAULT

SELECTOR BANK SW8		
SW8-1	SW8-2	DESCRIPTION
OFF	OFF	DEFAULT

OU CIRCUIT DIAGRAM 12.5 KW - 14 KW three-phase (1U125S2SN2FB - 1U140S2SP2FB)

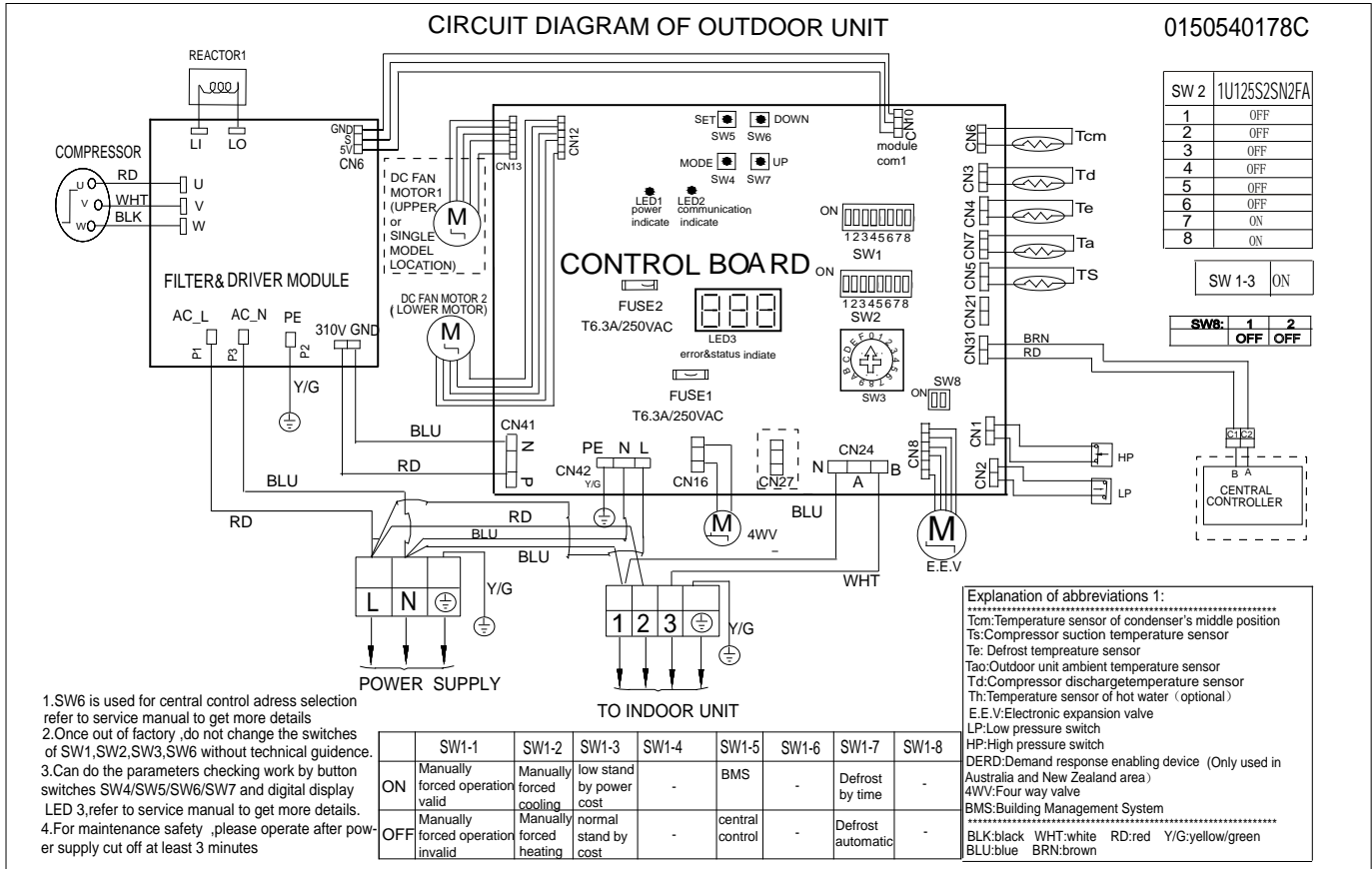

OU SETTINGS 12.5 KW - 14 KW three-phase (1U125S2SN2FB - 1U140S2SP2FB)

SW1 SELECTOR								DESCRIPTION
SW1-1	SW1-2	SW1-3	SW1-4	SW1-5	SW1-6	SW1-7	SW1-8	
ON	---	---	---	---	---	---	---	Forced disabling
OFF	---	---	---	---	---	---	---	Forced enabling
---	ON	---	---	---	---	---	---	Forced cooling (se SW1-1 ON)
---	OFF	---	---	---	---	---	---	Forced heating (se SW1-1 ON)
---	---	ON	---	---	---	---	---	Low consumption in stand by (DEFAULT)
---	---	OFF	---	---	---	---	---	Normal consumption in stand by
---	---	---	ON	---	---	---	---	N.D.
---	---	---	OFF	---	---	---	---	Control via BMS
---	---	---	---	ON	---	---	---	Control via centralised controller
---	---	---	---	OFF	---	---	---	N.D.
---	---	---	---	---	ON	---	---	Defrosting under specific conditions
---	---	---	---	---	OFF	---	---	Automatic defrosting (DEFAULT)
---	---	---	---	---	---	ON	---	Silent mode enabled
---	---	---	---	---	---	OFF	---	Silent mode disabled (DEFAULT)

SW2 SELECTOR								DESCRIPTION
SW2-1	SW2-2	SW2-3	SW2-4	SW2-5	SW2-6	SW2-7	SW2-8	
OFF	OFF	OFF	OFF	OFF	ON	ON	ON	1U140S2SN1FA
OFF	OFF	OFF	OFF	ON	OFF	OFF	OFF	1U140S2SN1FB
OFF	OFF	OFF	OFF	ON	ON	OFF	OFF	1U160S2SN1FB
OFF	OFF	OFF	OFF	OFF	OFF	ON	ON	1U125S2SN2FA
OFF	OFF	OFF	OFF	OFF	ON	OFF	OFF	1U125S2SN2FB
OFF	OFF	OFF	OFF	ON	OFF	ON	OFF	1U140S2SP2FB

SELECTOR BANK SW3	
SW3	DESCRIPTION
0	DEFAULT

SELECTOR BANK SW8		
SW8-1	SW8-2	DESCRIPTION
OFF	OFF	DEFAULT

OU CIRCUIT DIAGRAM 14 KW three-phase (1U140S2SN1FB)

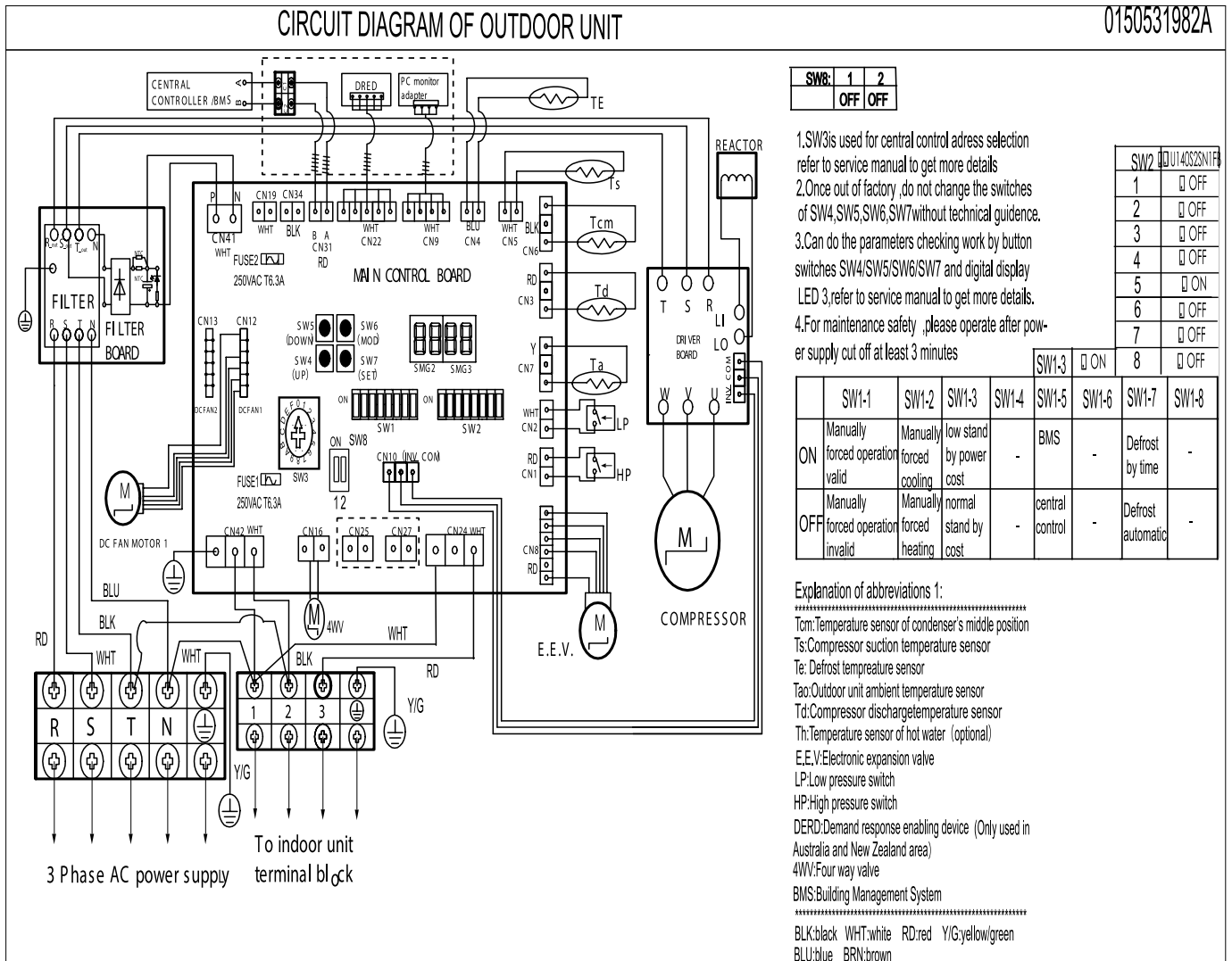

OU SETTINGS 14 KW three-phase (1U140S2SN1FB)

SELECTOR BANK SW1								DESCRIPTION
SW1-1	SW1-2	SW1-3	SW1-4	SW1-5	SW1-6	SW1-7	SW1-8	
OFF	---	---	---	---	---	---	---	FORCED DISABLING
ON	---	---	---	---	---	---	---	FORCED ENABLING
---	OFF	---	---	---	---	---	---	FORCED COOLING (SE SW1-1 ON)
---	ON	---	---	---	---	---	---	FORCED HEATING (SE SW1-1 ON)
---	---	ON	---	---	---	---	---	LOW CONSUMPTION IN STAND BY (DEFAULT)
---	---	OFF	---	---	---	---	---	NORMAL CONSUMPTION IN STAND BY
---	---	---	OFF	---	---	---	---	N.D.
---	---	---	---	ON	---	---	---	CONTROL VIA BMS
---	---	---	---	OFF	---	---	---	CONTROL VIA CENTRALISED CONTROLLER
---	---	---	---	---	OFF	---	---	N.D.
---	---	---	---	---	---	ON	---	DEFROSTING UNDER SPECIFIC CONDITIONS
---	---	---	---	---	---	OFF	---	AUTOMATIC DEFROSTING (DEFAULT)
---	---	---	---	---	---	---	ON	SILENT MODE ENABLED
---	---	---	---	---	---	---	OFF	SILENT MODE DISABLED (DEFAULT)

SELECTOR BANK SW2								DESCRIPTION
SW2-1	SW2-2	SW2-3	SW2-4	SW2-5	SW2-6	SW2-7	SW2-8	
OFF	OFF	OFF	OFF	OFF	ON	ON	ON	1U140S2SN1FA
OFF	OFF	OFF	OFF	ON	OFF	OFF	OFF	1U140S2SN1FB
OFF	OFF	OFF	OFF	ON	ON	OFF	OFF	1U160S2SP1FB

SELECTOR BANK SW3	
SW3	DESCRIPTION
0	DEFAULT

SELECTOR BANK SW8		
SW8-1	SW8-2	DESCRIPTION
OFF	OFF	DEFAULT

OU CIRCUIT DIAGRAM 16 KW three-phase (1U160S2SP1FB)

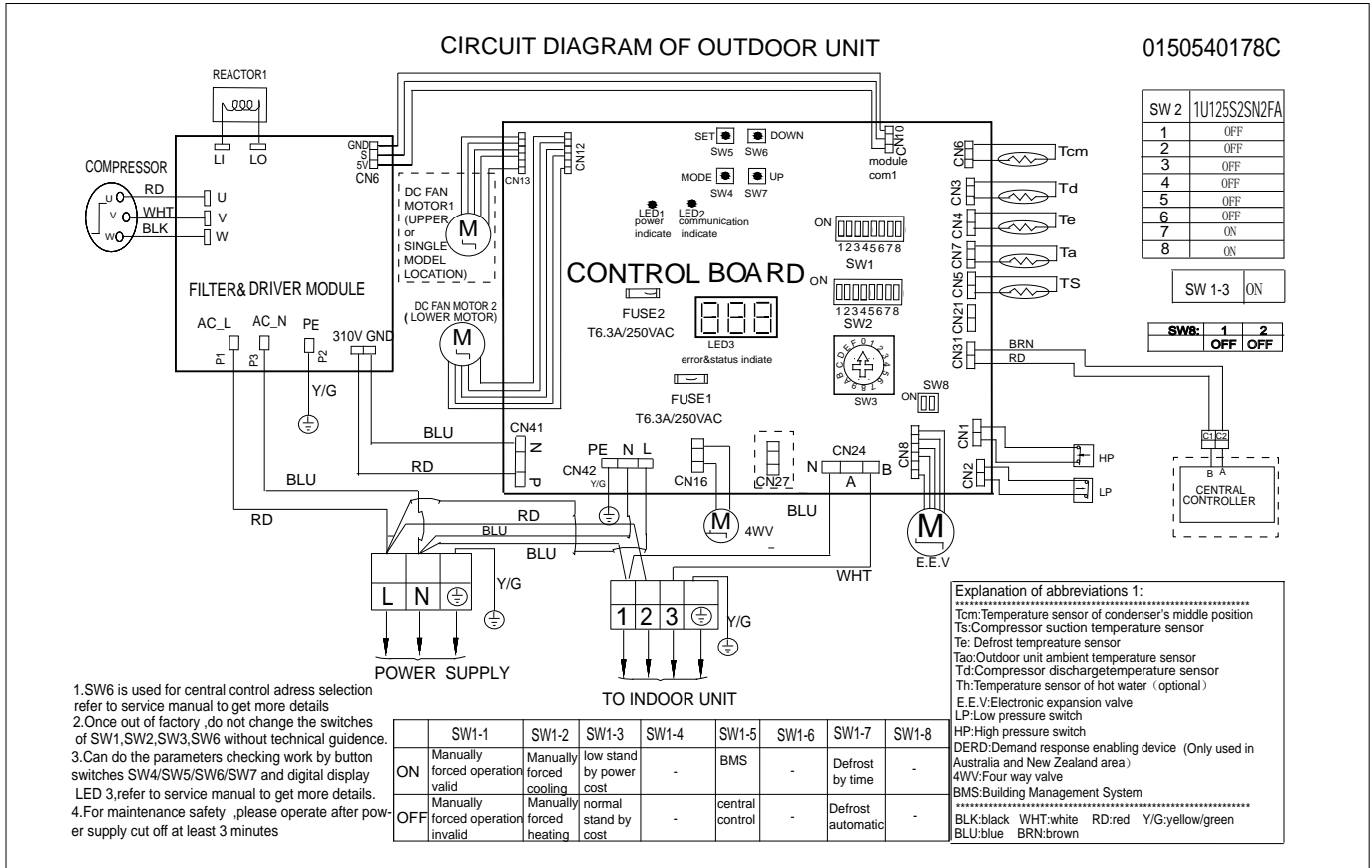

OU CIRCUIT DIAGRAM 16 KW three-phase (1U160S2SP1FB)

SELECTOR BANK SW1								DESCRIPTION
SW1-1	SW1-2	SW1-3	SW1-4	SW1-5	SW1-6	SW1-7	SW1-8	
OFF	---	---	---	---	---	---	---	FORCED DISABLING
ON	---	---	---	---	---	---	---	FORCED ENABLING
---	OFF	---	---	---	---	---	---	FORCED COOLING (SE SW1-1 ON)
---	ON	---	---	---	---	---	---	FORCED HEATING (SE SW1-1 ON)
---	---	ON	---	---	---	---	---	LOW CONSUMPTION IN STAND BY (DEFAULT)
---	---	OFF	---	---	---	---	---	NORMAL CONSUMPTION IN STAND BY
---	---	---	OFF	---	---	---	---	N.D.
---	---	---	---	OFF	---	---	---	CONTROL VIA BMS
---	---	---	---	---	OFF	---	---	CONTROL VIA CENTRALISED CONTROLLER
---	---	---	---	---	---	OFF	---	N.D.
---	---	---	---	---	---	ON	---	DEFROSTING UNDER SPECIFIC CONDITIONS
---	---	---	---	---	---	OFF	---	AUTOMATIC DEFROSTING (DEFAULT)
---	---	---	---	---	---	---	ON	SILENT MODE ENABLED
---	---	---	---	---	---	---	OFF	SILENT MODE DISABLED (DEFAULT)

SELECTOR BANK SW2								DESCRIPTION
SW2-1	SW2-2	SW2-3	SW2-4	SW2-5	SW2-6	SW2-7	SW2-8	
OFF	OFF	OFF	OFF	OFF	ON	ON	ON	1U140S2SN1FA
OFF	OFF	OFF	OFF	ON	OFF	OFF	OFF	1U140S2SN1FB
OFF	OFF	OFF	OFF	ON	ON	OFF	OFF	1U160S2SP1FB

SELECTOR SW3	
SW3	DESCRIPTION
0	DEFAULT

SELECTOR BANK SW8		
SW8-1	SW8-2	DESCRIPTION
OFF	OFF	DEFAULT

Outdoor units

- (2) 2U40S2SM1FA (2 couplings) 4.2 kW
- (1-2) 2U50S2SM1FA-3 (2 couplings) 5.0 kW
- (1-2) 3U55S2SR5FA (3 couplings) 5.5 kW
- (1-2) 3U70S2SR5FA (3 couplings) 7.0 kW
- (1-2) 4U75S2SR5FA (4 couplings) 7.5 kW
- (1-2) 4U85S2SR5FA (4 couplings) 8.5 kW
- (1-2) 5U90S2SS5FA (5 couplings) 9.0 kW
- (1-2) 5U105S2SS5FA (5 couplings) 10.5 kW
- 5U125S2SN1FA (5 couplings) 12.5 kW

CIRCUIT DIAGRAM 1:2

2U40S2SM1FA - 2U50S2SM1FA-3

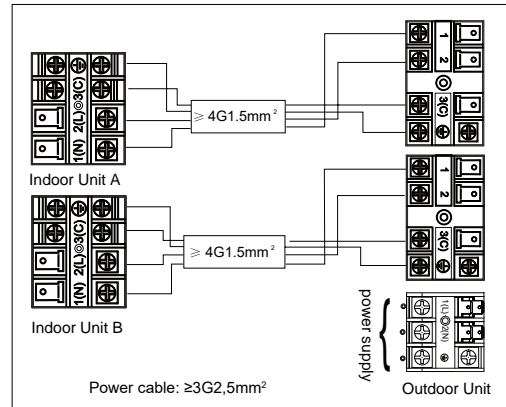

CIRCUIT DIAGRAM

1:3 3U55S2SR5FA - 3U70S2SR5FA / 1:4 4U75S2SR5FA - 4U85S2SR5FA / 1:5 5U90S2SS5FA - 5U105S2SS5FA - 5U125S2SN1FA

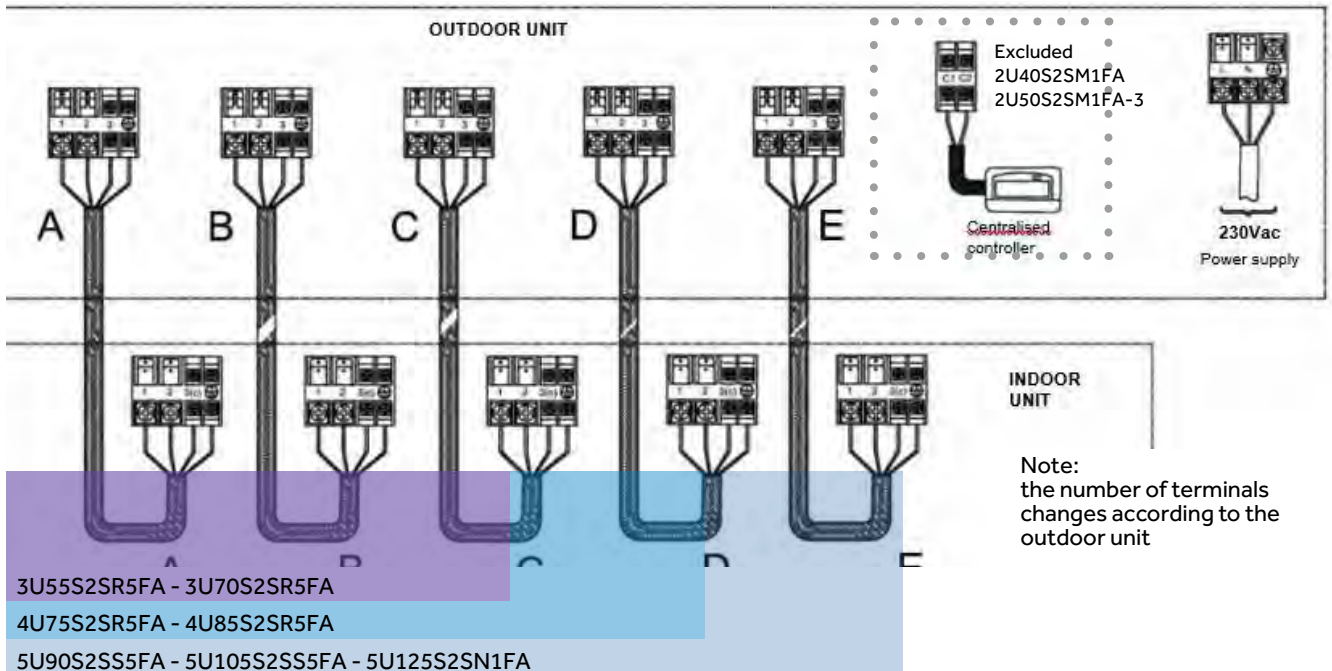

OUTDOOR UNIT		2U40S2SM1FA	2U50S2SM1FA-3	3U55S2SR5FA	3U70S2SR5FA
Outdoor unit technical data					
Power Supply	Ph/V/Hz	1/220~240/50	1/220~240/50	1/220~240/50/60	1/220~240/50/60
Liquid pipe Ø	mm	2x6.35	2x6.35	3x6.35	3x6.35
Gas pipe Ø	mm	2x9.52	2x9.52	3x9.52	3x9.52
Total maximum pipe length	m	30	30	50	60
Maximum single line OU-IU pipe length	m	20	20	25	25
Standard pipe length					
without additional refrigerant charge	m	20	20	30	30
Maximum IU - OU height difference	m	15	15	15	15
Max IU - IU height difference	m	7.5	7.5	7.5	7.5
Refrigerant charge in the factory R32	kg	1.0	1.1	1.4	1.6
Additional refrigerant charge R32	g/m	20	20	20	20
Dimensions (WxDxH)	mm	800x275x553	800x275x553	890x340x700	890x340x700
Net weight	kg	34	36	50	54
Outdoor unit power cable	mm²	3G1.5	3G1.5	3G2.5	3G2.5
Outdoor unit - Indoor unit cable	mm²	4G1.5	4G1.5	4G1.5	4G1.5

MULTI DIAGNOSTICS

Refer to the alarm list on **page XX**.

OUTDOOR UNIT		4U75S2SR5FA	4U85S2SR5FA	5U90S2SS5FA	5U105S2SS5FA	5U125S2SN1FA
Outdoor unit technical data						
Power Supply	Ph/V/Hz	1/220~240/50/60	1/220~240/50/60	1/220~240/50/60	1/220~240/50/60	1/220~240/50/60
Liquid pipe Ø	mm	4x6.35	4x6.35	5x6.35	5x6.35	5x6.35
Gas pipe Ø	mm	3x9.52 + 1x12.7	3x9.52 + 1x12.7	3x9.52 + 2x12.7	3x9.52 + 2x12.7	3x9.52+2x12.7
Total maximum pipe length	m	70	70	80	80	100
Maximum single line OU-IU pipe length	m	25	25	25	25	25
Standard pipe length without additional refrigerant charge	m	40	40	40	40	50
Maximum IU - OU height difference	m	15	15	15	15	15
Max IU - IU height difference	m	7.5	7.5	7.5	7.5	7.5
Refrigerant charge in the factory R32	kg	2.2	2.2	2.4	2.4	2.5
Additional refrigerant charge R32	g/m	20	20	20	20	20
Dimensions (WxDxH)	mm	890x340x700	890x340x700	920x372x765	920x372x765	950x370x965
Net weight	kg	61	61	66	66	79
Outdoor unit power cable	mm ²	3G2.5	3G4	3G4	3G4	3G4
Outdoor unit - Indoor unit cable	mm ²	4G1.5	4G1.5	4G1.5	4G1.5	4G1.5

OU CIRCUIT DIAGRAM 2U40S2SM1FA 4.0 KW - 2U50S2SM1FA-3 5.0 KW

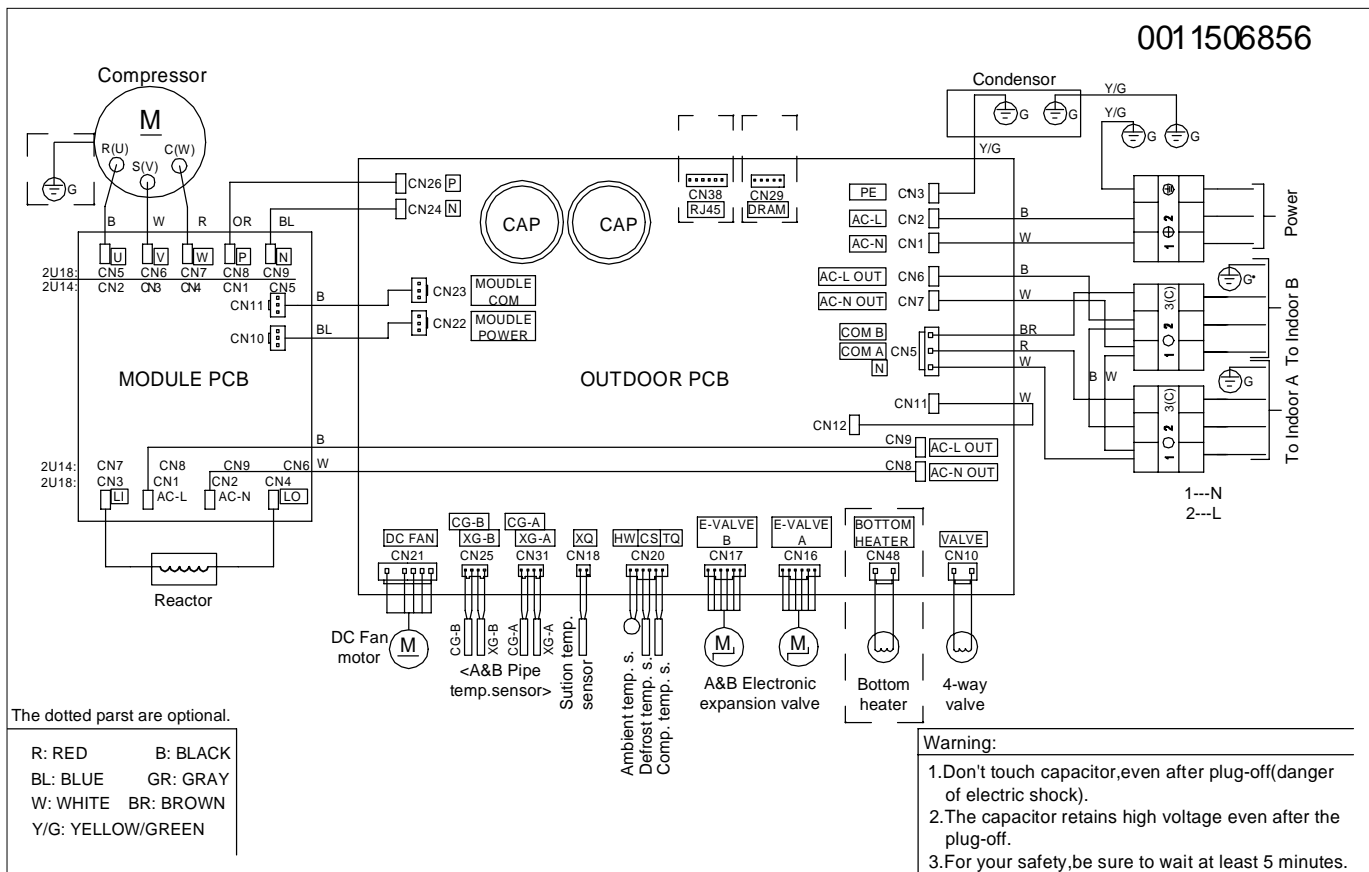

SETTINGS:

MODEL	J3	
HAIER	2U40S2SM1FA	OFF
	2U50S2SM1FA-3	ON

OU CIRCUIT DIAGRAM 3U55S2SR5FA 5.5 KW - 3U70S2SR5FA 7.0 KW

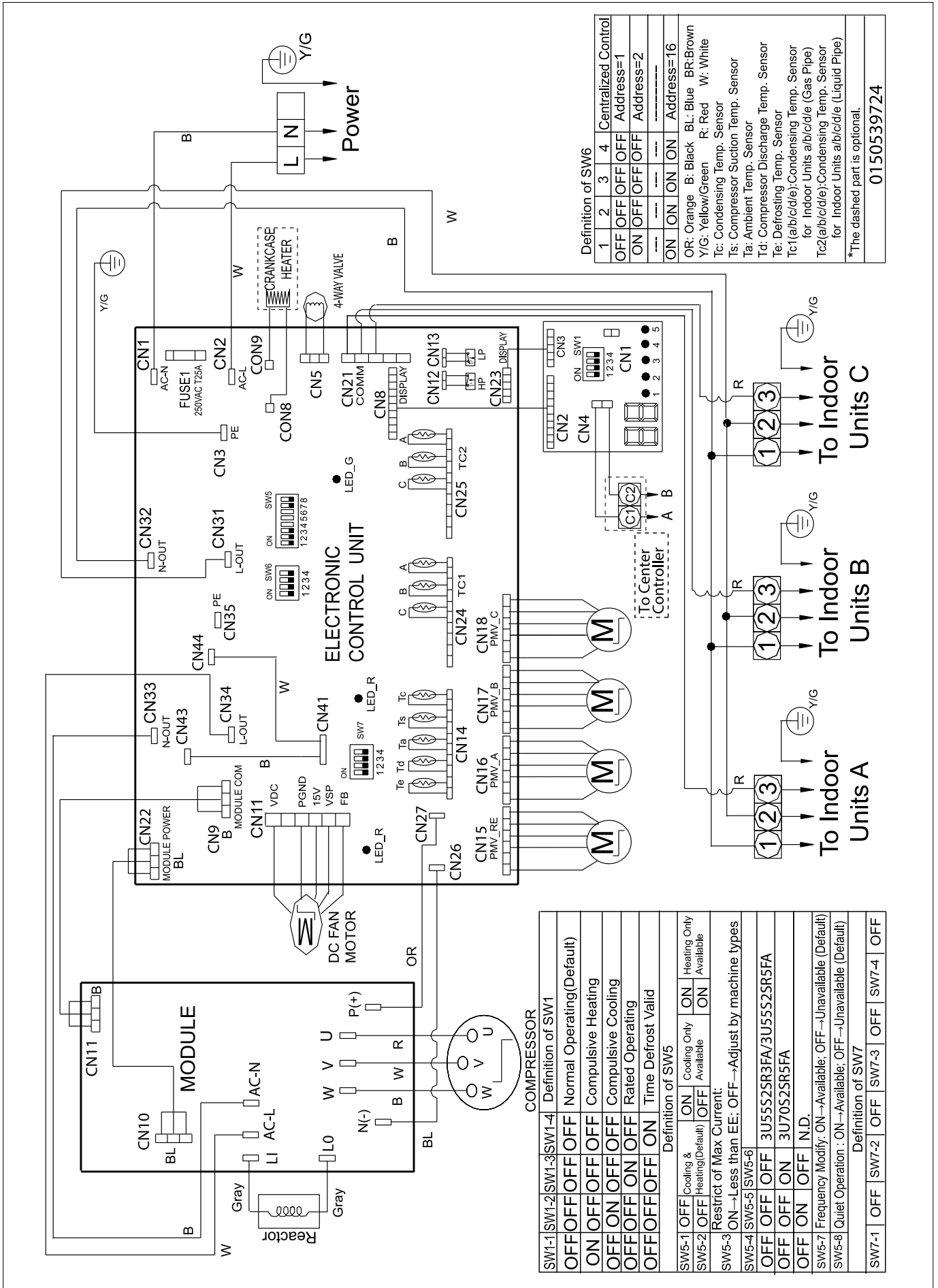

Definition of SW6			
1	2	3	4
OFF	OFF	OFF	Centralized Control Address=1
ON	OFF	OFF	Address=2
ON	ON	ON	Address=16

OR: Orange B: Black BL: Blue BR: Brown
 Y/G: Yellow/Green R: Red W: White
 Tc: Condensing Temp. Sensor
 Ts: Compressor Suction Temp. Sensor
 Ta: Ambient Temp. Sensor
 Td: Compressor Discharge Temp. Sensor
 Te: Defrosting Temp. Sensor
 Tc1(a/b/c/d/e): Condensing Temp. Sensor for Indoor Units a/b/c/d/e (Gas Pipe)
 Tc2(a/b/c/d/e): Condensing Temp. Sensor for Indoor Units a/b/c/d/e (Liquid Pipe)
 *The dashed part is optional.

0150539724

Definition of SW1			
SW1-1	SW1-2	SW1-3	SW1-4
OFF	OFF	OFF	Normal Operating(Default)
ON	OFF	OFF	Compulsive Heating
ON	OFF	OFF	Compulsive Cooling
OFF	OFF	ON	Rated Operating
OFF	OFF	OFF	Time Defrost Valid

Definition of SW5			
SW5-1	OFF	Cooling & Heating(Default)	ON
SW5-2	OFF	Cooling Only	ON
SW5-3	ON	Restrict of Max Current:	ON
SW5-4	OFF	ON → Less than EE; OFF → Adjust by machine types	ON
SW5-5	OFF	3U55S2SR3FA/3U55S2SR5FA	ON
SW5-6	OFF	3U70S2SR5FA	ON
SW5-7	OFF	Frequency Modify: ON → Available; OFF → Unavailable (Default)	ON
SW5-8	OFF	Quiet Operation: ON → Available; OFF → Unavailable (Default)	ON

Definition of SW7			
SW7-1	OFF	SW7-2	OFF
SW7-3	OFF	SW7-4	OFF

OU CIRCUIT DIAGRAM 4U75S2SR5FA 7.5 KW - 4U85S2SR5FA 8.5 KW - 5U90S2SS5FA 9.0 KW - 5U105S2SS5FA 10.5 KW

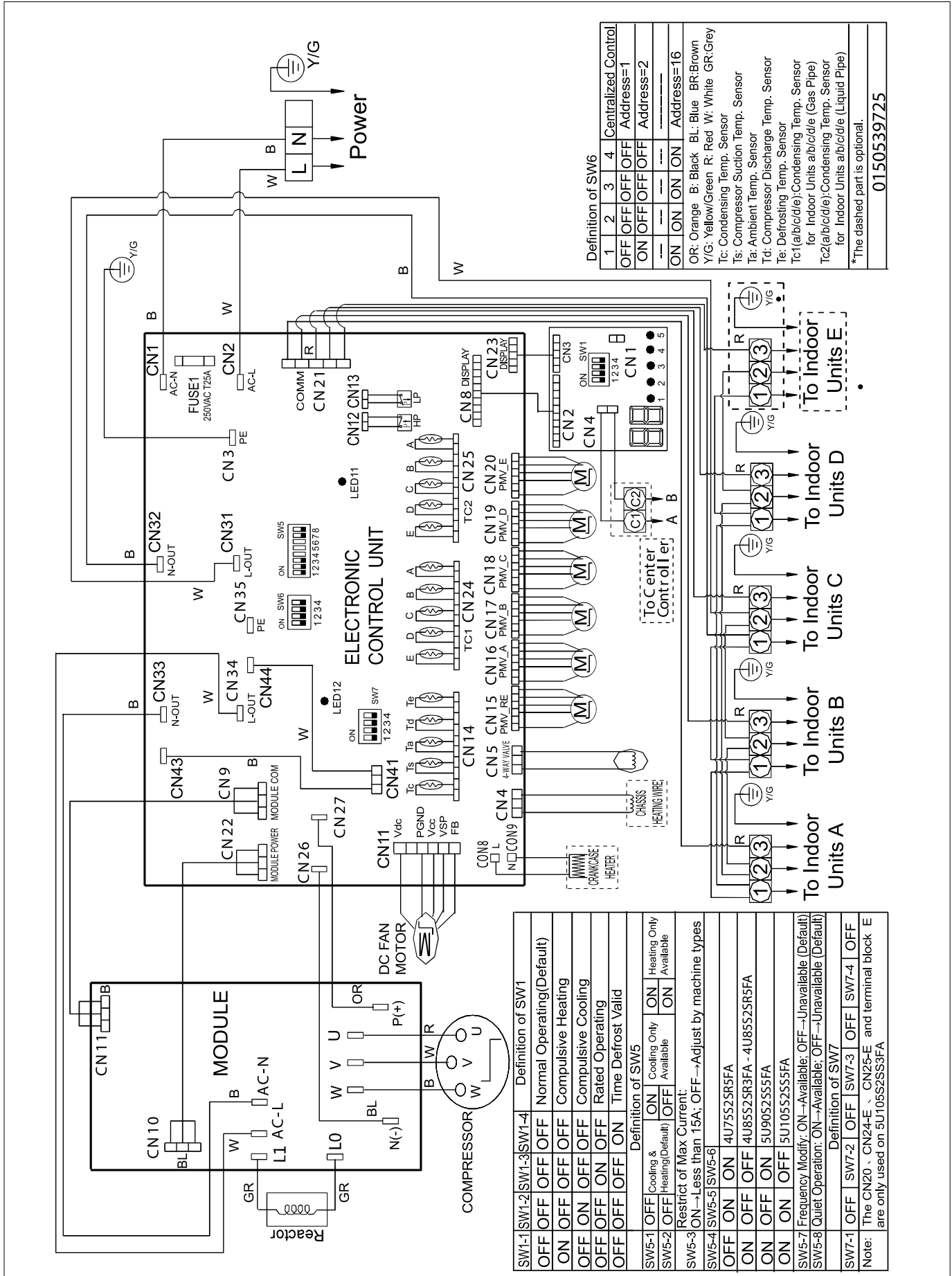

Definition of SW6

1	2	3	4	Centralized Control
OFF	OFF	OFF	OFF	Address=1
ON	OFF	OFF	OFF	Address=2
---	---	---	---	Address=16
ON	ON	ON	ON	Address=16

OR: Orange B: Black BL: Blue BR: Brown
Y/G: Yellow/Green R: Red W: White GR: Grey
Tc: Condensing Temp. Sensor
Ts: Compressor Suction Temp. Sensor
Ta: Ambient Temp. Sensor
Td: Compressor Discharge Temp. Sensor
Tc1: (a/b/c/d/e); Condensing Temp. Sensor for Indoor Units a/b/c/d/e (Gas Pipe)
Tc2: (a/b/c/d/e); Condensing Temp. Sensor for Indoor Units a/b/c/d/e (Liquid Pipe)
*The dashed part is optional.

SW1-1	SW1-2	SW1-3	SW1-4	Definition of SW1			
OFF	OFF	OFF	OFF	Normal Operating (Default)			
ON	OFF	OFF	OFF	Compulsive Heating			
OFF	ON	OFF	OFF	Compulsive Cooling			
OFF	OFF	ON	OFF	Rated Operating			
OFF	OFF	OFF	ON	Time Defrost Valid			
Definition of SW5							
SW5-1	OFF	COOLING & HEATING	ON	Cooling Only			
SW5-2	OFF	HEATING (Default)	OFF	Available			
Restrict of Max Current:							
SW5-3	ON	Less than 15A	OFF	Adjust by machine types			
SW5-4	SW5-5	SW5-6					
OFF	ON	ON	4U75S2SR5FA				
ON	OFF	OFF	4U85S2SR3FA - 4U85S2SR5FA				
ON	OFF	ON	5U90S2SS5FA				
ON	ON	OFF	5U105S2SS5FA				
SW5-7 Frequency Modify: ON→Available; OFF→Unavailable (Default)							
SW5-8 Quiet Operation: ON→Available; OFF→Unavailable (Default)							
Definition of SW7							
SW7-1	OFF	SW7-2	OFF	SW7-3	OFF	SW7-4	OFF
Note: The CN20、CN24-E、CN25-E and terminal block E are only used on 5U105S2SS3FA							

0150539725

OUTDOOR MOTHERBOARD SETTING 0151800364A (FOR 3U/4U/5U MODELS):

The settings listed below are to be performed in the SW5 block of the motherboard:

SW5								DESCRIPTION
1	2	3	4	5	6	7	8	
OFF	OFF	---	---	---	---	---	---	HEAT PUMP (default)
ON	OFF	---	---	---	---	---	---	COOLING-ONLY
ON	ON	---	---	---	---	---	---	HEAT PUMP ONLY
---	---	OFF	---	---	---	---	---	ABSORPTION ACCORDING TO PAIRING
---	---	ON	---	---	---	---	---	MAX 15A ABSORPTION
---	---	---	OFF	OFF	OFF	---	---	MODEL 3U55S2SR3FA - 3U55S2SR5FA
---	---	---	OFF	OFF	ON	---	---	MODEL 3U70S2SR5FA
---	---	---	OFF	ON	ON	---	---	MODEL 4U75S2SR5FA
---	---	---	ON	OFF	OFF	---	---	MODEL 4U85S2SR3FA - 4U85S2SR5FA
---	---	---	ON	OFF	ON	---	---	MODEL 5U90S2SS5FA
---	---	---	ON	ON	OFF	---	---	MODEL 5U105S2SS5FA
---	---	---	---	---	---	OFF	---	TEMPERATURE CORRECTION DISABLED (DEFAULT)
---	---	---	---	---	---	ON	---	TEMPERATURE CORRECTION ENABLED
---	---	---	---	---	---	---	OFF	QUIET MODE DISABLED (DEFAULT)
---	---	---	---	---	---	---	ON	QUIET MODE ENABLED

Selecting the mode (SW5-1\2):

Selecting the default mode of operation: keep both selectors in OFF

Selecting the absorption limit (SW5-3):

The system has a limitation hat can lower the consumption of the device from the maximum reachable to the nominal. Raising the switch 3 of SW5 limits the absorption to a maximum of 15A.

Selecting the outdoor unit power (SW5-4\5\6):

Through switches 4-5-6 of SW5, it is possible to select the power and consequently the model of the outdoor unit where the motherboard is to be applied.

Function not available (SW5-7):

Function not available, keep the selector in OFF.

QUIET mode (SW5-8):

The QUIET function allows you to reduce the frequency of the compressor so that the compressor becomes quieter.

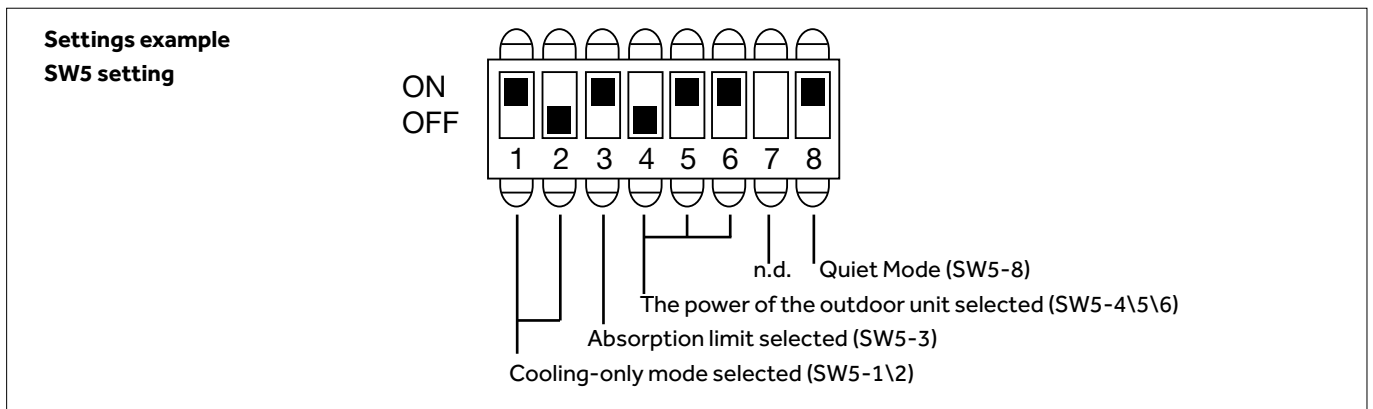

SW7				DESCRIPTION
1	2	3	4	
---	ON	ON	---	DEFROSTING THRESHOLD: 6°C
---	OFF	OFF	---	DEFROSTING THRESHOLD: 8°C (DEFAULT)

OUTDOOR MOTHERBOARD SETTING 0151800578A

The settings listed below are to be performed in the SW5 block of the motherboard:

SW5								DESCRIPTION
1	2	3	4	5	6	7	8	
OFF	---	---	---	---	---	---	---	HEAT PUMP (default)
ON	---	---	---	---	---	---	---	COOLING-ONLY
---	OFF	---	---	---	---	---	---	DEFROSTING THRESHOLD 8°C (DEFAULT)
---	ON	---	---	---	---	---	---	DEFROSTING THRESHOLD 6°C
---	---	OFF	---	---	---	---	---	ABSORPTION ACCORDING TO PAIRING
---	---	ON	---	---	---	---	---	MAX 15A ABSORPTION
---	---	---	ON	ON	ON	---	---	MODEL 5U125S2SN1FA
---	---	---	---	---	---	OFF	---	TEMPERATURE CORRECTION DISABLED (DEFAULT)
---	---	---	---	---	---	ON	---	TEMPERATURE CORRECTION ENABLED
---	---	---	---	---	---	---	OFF	QUIET MODE DISABLED (DEFAULT)
---	---	---	---	---	---	---	ON	QUIET MODE ENABLED

Selecting the mode (SW5-1\2):

Selecting the default mode of operation: keep both selectors in OFF

Selecting the mode (SW5-2):

Select the threshold for defrost intervention (8° default).

Selecting the absorption limit (SW5-3):

The system has a limitation hat can lower the consumption of the device from the maximum reachable to the nominal. Raising the switch 3 of SW5 limits the absorption to a maximum of 15A.

Selecting the outdoor unit power (SW5-4\5\6):

Through switches 4-5-6 of SW5, it is possible to select the power and consequently the model of the outdoor unit where the motherboard is to be applied.

Function not available (SW5-7):

Function not available, keep the selector in OFF.

QUIET mode (SW5-8):

The QUIET function allows you to reduce the frequency of the compressor so that the compressor becomes quieter.

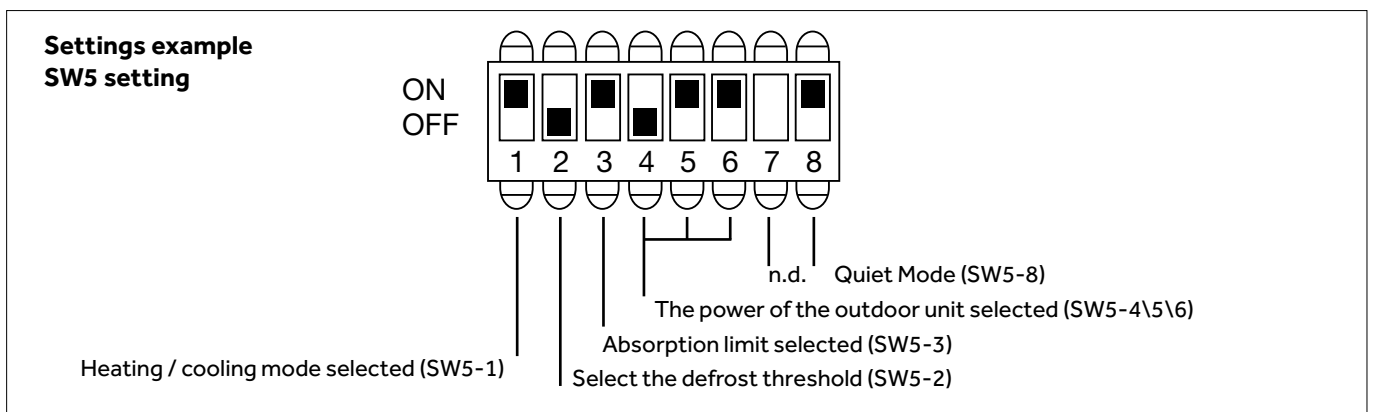

OUTDOOR UNIT ADDRESSING FOR PLANT MANAGEMENT VIA CENTRALIZED CONTROLLER SW6

SW6 block of the main board of the outdoor unit is used to address indoor units in order to manage the plant by centralized controller (YCZ-A004 / YCZ-G001 / HC-SA164DBT).

The centralized controller reserves five indoor unit addresses for each connected outdoor unit (even if the outdoor has less than five couplings).

ATTENTION: Two-coupling outdoor units 2U40S2SM1FA, 2U50S2SM1FA-3 do not support centralized controllers CZ-A004 / YCZ-G001 / HC-SA164DBT.

The setting to be performed is as follows:

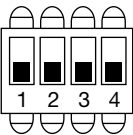
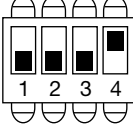
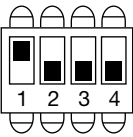
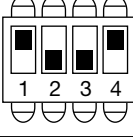
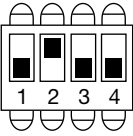
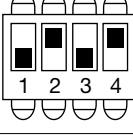
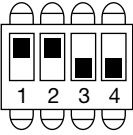
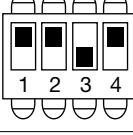
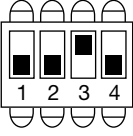
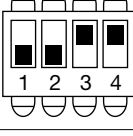
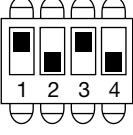
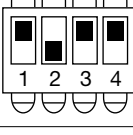
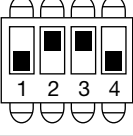
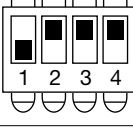
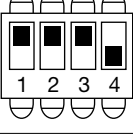
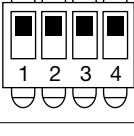
OU NUMBER	SW6	IU ADDRESSES	OU NUMBER	SW6	IU ADDRESSES
1	ON OFF 	1 to 5	9	ON OFF 	41 to 45
2	ON OFF 	6 to 10	10	ON OFF 	46 to 50
3	ON OFF 	11 to 15	11	ON OFF 	51 to 55
4	ON OFF 	16 to 20	12	ON OFF 	56 to 60
5	ON OFF 	21 to 25	13	ON OFF 	61 to 65
6	ON OFF 	26 to 30	14	ON OFF 	66 to 70
7	ON OFF 	31 to 35	15	ON OFF 	71 to 75
8	ON OFF 	36 to 40	16	ON OFF 	76 to 80

For the circuit diagram with HC-SA164DBT interface, refer to the diagram on **page XX**.

CONTROL VIA SW1

Settings for service board on outdoor
0151800076A / 0151800076B

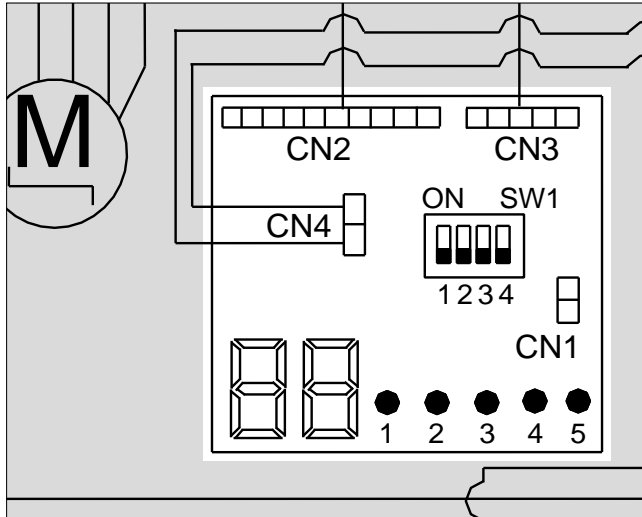

The settings listed below are to be performed in the SW1 block of the outdoor service board:

SW1	DESCRIPTION
ON OFF 	DEFAULT SETTINGS NORMAL OPERATION
ON OFF 	FORCED HEATING: 50HZ, outdoor fan in step 5, valve opening 200°, the rest under normal conditions
ON OFF 	FORCED COOLING: 60HZ, outdoor fan in step 7, valve opening 200°, the rest under normal conditions
ON OFF 	NOMINAL OPERATING LIMIT: limits the output of the unit to the respective rated power
ON OFF 	FORCED DEFROST EVERY 50 MINUTES: The outdoor unit will perform a forced defrosting every 50 minutes if the outside ambient temperature is less than 7°C
ON OFF 	INCORRECT WIRING TEST

Forcing the system (heating\cooling) (SW1-1\2):

The system has the ability to be forced into both cooling and heat pump via switches 1 and 2 of SW1.

- Raising switch 1 forces the plant into "Heat Pump"
- Raising the switch 2 forces the plant into "Cooling"

When performing this forced operation, the indoor units will start automatically, make sure before forcing the system that the indoor units are turned off.

Wrong wiring test (SW1-1\2\3\4)

To perform the "WRONG WIRING TEST" you have to place the dip switches of the SW1 block all to "ON" before powering on the system, so as to prevent other settings (e.g. FORCED COOLING).

The indoor units automatically turn on in cooling mode, the abbreviation "CH" starts flashing on the outdoor unit's display.

The outdoor unit opens the expansion valves one at a time and compares the data that the indoor units detect, so that you can see if the refrigerant passage occurs on the unit "A", "B" and so on, to find the discrepancies between electrical connection and refrigerator and notify the user.

With regard to the test on the 3U55S2SR5FA unit, after about 20 minutes of operation, there is already a signal for incorrect wiring, with a flashing of the LEDs (of the service board) corresponding to the inverted indoor units.

After about 30 minutes the test cycle ends, the system automatically shuts down.

In the case of inversion of wiring, the abbreviation "EC" appears on the display of the service board and LEDs corresponding to the inverted indoor units flash.

For models with multiple couplings, the test times are slightly longer, about 10 minutes per indoor unit.

MANUAL TEST MODE

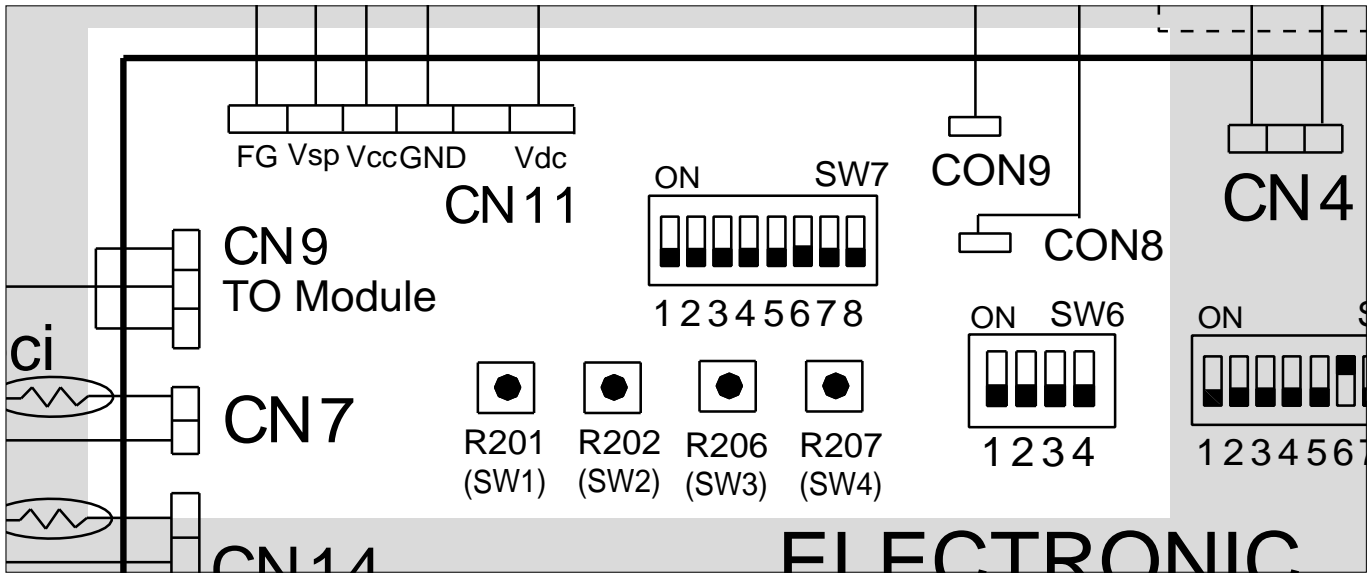

Reading data

In the forced operation modes of the plant, both heat pump and cooling can be manually accessed and adjusted in the plant settings. Using the selection keys listed below you can enter the various menus to change the parameters. With DEFAULT settings, you have access to the read-only parameters, but you cannot make any adjustments.

In DEFAULT mode (NORMAL OPERATION) only parameters A0 and A9 can be displayed.

Selection keys:

- The "R201"/(SW1) bridge on the motherboard is used to increase the adjustment steps;
- The "R202"/(SW2) bridge on the motherboard is used to decrease the adjustment steps;
- The "R206"/(SW3) bridge on the motherboard is used to confirm the selected menu;
- The bridge "R207"/(SW4) on the motherboard is used to switch between functions (from function "A0" to function "A9").

Unit control

In Forced Mode, pressing the "R207" bridge accesses all the underlying functions. The "R201" and "R202" bridges change the operating parameters:

"A0"	Indoor Diagnostics The alarm list of connected indoor units is available;
A1	Outdoor fan motor speed You can test and adjust the speed of the outdoor fan in steps (steps range from 0 to 7);
A2	Compressor Frequency You can test and adjust the frequency of the compressor in steps (the frequency rises up to a maximum of 130Hz);
A3	Expansion valve opening "A" You can test and adjust the opening of expansion valve in degrees (from a minimum of 5° to 500°);
A4	Expansion valve opening "B" You can test and adjust the opening of expansion valve in degrees (from a minimum of 5° to 500°);
A5	Expansion valve opening "C" You can test and adjust the opening of expansion valve in degrees (from a minimum of 5° to 500°);
A6	Expansion valve opening "D" You can test and adjust the opening of expansion valve in degrees (from a minimum of 5° to 500°);
A7	Expansion valve opening "E" You can test and adjust the opening of expansion valve in degrees (from a minimum of 5° to 500°);
A8	Expansion valve opening "F" (PMV_RE) You can test and adjust the opening of expansion valve in degrees (from a minimum of 5° to 500°);
A9	Outdoor Diagnostics A list of the last 5 alarms related to the outdoor unit is available.

Outdoor units
1UH200W1ERK (20 kW) (three-phase)
1UH250W1ERK (25 kW) (three-phase)

OUTDOOR UNIT		1UH200W1ERK	1UH250W1ERK
Outdoor unit technical data			
Liquid pipe Ø	mm	9.52	9.52
Gas pipe Ø	mm	19.05	*22,22
Standard pipe length without additional refrigerant charge	m	30	30
Maximum pipe length	m	75	75
Maximum IU - OU height difference	m	50	50
Refrigerant charge in the factory	kg	6.10	6.10
Equivalent tons of CO ²	tCO ₂ EQ	13.25	13.25
Additional refrigerant charge beyond standard length	g/m	45	45
Power Supply	V-Ph-Hz	3/380-415/50/60	3/380-415/50/60
Outdoor unit power cable	mm ²	5G2.5	5G2.5
Outdoor unit - indoor unit cable	mm ²	4G1.5	4G1.5

* To connect the unit to the gas pipe, it is necessary to use a 19.05 mm pipe connector at collar, to be welded to the 22.22 mm gas pipe. The pipe connector is not supplied with the unit.

DIAGNOSTICS IU-OU 20 KW - 25 KW

See **page XX**.

CIRCUIT DIAGRAM 20 KW - 25 KW

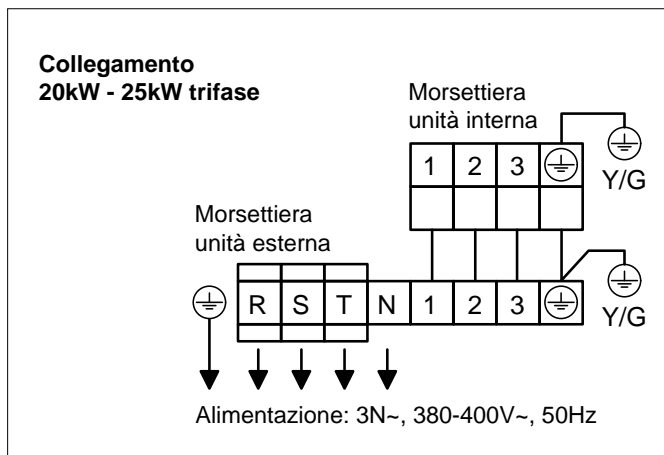

OU CIRCUIT DIAGRAM 20 KW (1UH200W1ERK) - 25 KW (1UH250W1ERK)

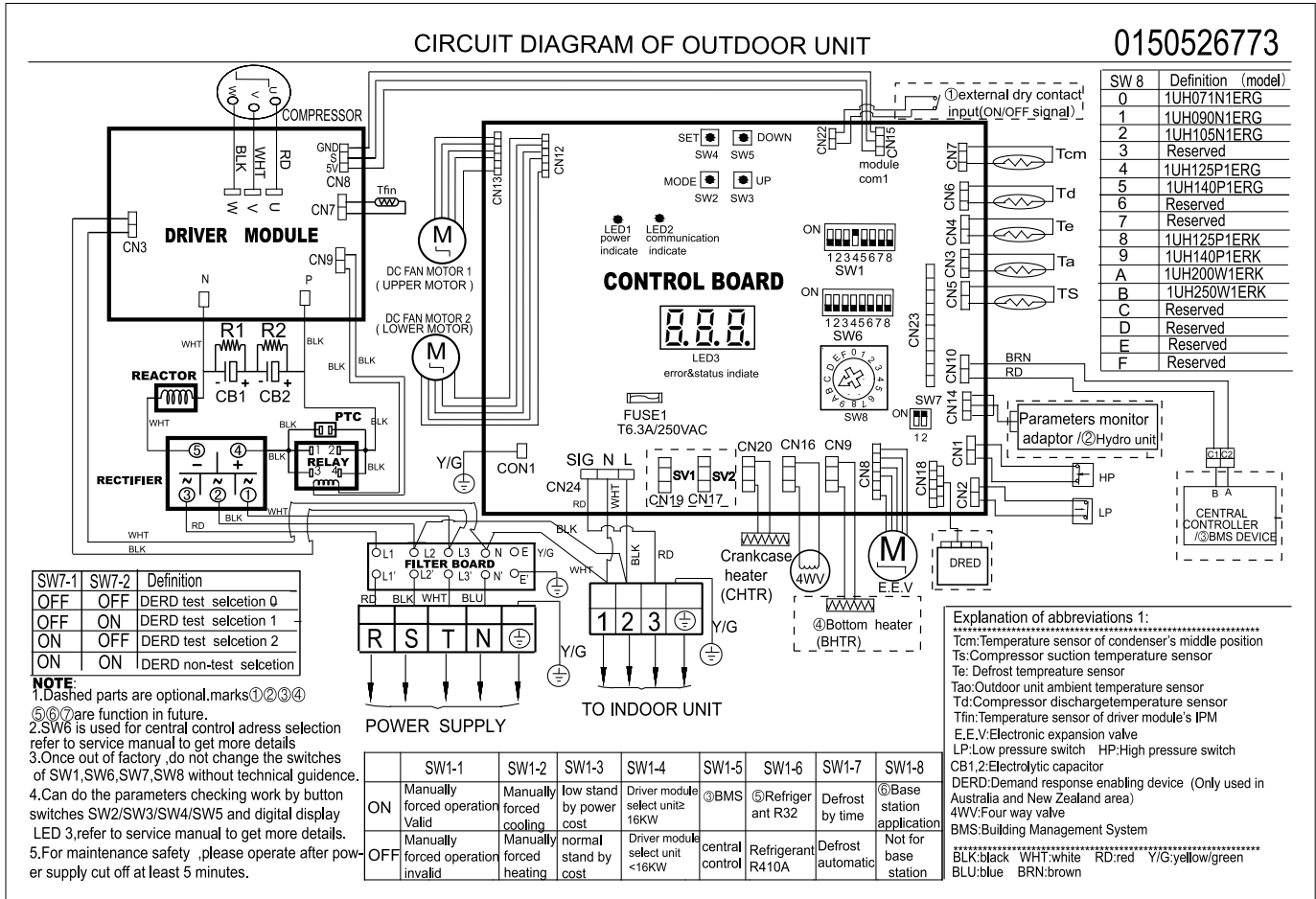

OU SETTINGS 20 KW - 25 KW

SW1 1=ON 0=OFF								Description	Default position
Forced mode	Stand by	Mode	Remote controller	Refrigerant	Defrost	Reserved			
SW1-1	SW1-2	SW1-3	SW1-4	SW1-5	SW1-6	SW1-7	SW1-8		
OFF	---	---	---	---	---	---	---	Manual forcing disabled	x
ON	---	---	---	---	---	---	---	Manual forcing enabled	
---	OFF	---	---	---	---	---	---	Forced heating	x
---	ON	---	---	---	---	---	---	Forced cooling	
---	---	OFF	---	---	---	---	---	Normal stand by	x
---	---	ON	---	---	---	---	---	Low consumption stand by	
---	---	---	OFF	---	---	---	---	Water heating - only heating	
---	---	---	ON	---	---	---	---	Air conditioning mode	x
---	---	---	---	OFF	---	---	---	Centralised controller	x
---	---	---	---	ON	---	---	---	BMS control	
---	---	---	---	---	OFF	---	---	R410A refrigerant	x
---	---	---	---	---	ON	---	---	R32 refrigerant	
---	---	---	---	---	---	OFF	---	Automatic defrosting	x
---	---	---	---	---	---	ON	---	Timed defrosting	
---	---	---	---	---	---	---	OFF	Reserved	x

Enabling forced mode (SW1-1①②):

To force the air conditioner mode, set switch SW1-1 to ON, then use switch SW2-2 to select heating (OFF) or cooling (ON).

Stand by mode (SW1-3):

Placing this switch in ON enables low-power function when the air conditioner is on stand by

Water heater - air conditioning (SW1-4):

Placing in ON enables the "heating only" function. The factory setting is OFF.

Remote Control (SW1-5):

It is possible to control the air conditioner remotely using the centralized controller (e.g. YCZ-A004) with OFF switch, or by pc (e.g. BMS) with ON switch

Refrigerant (SW1-6):

Using this switch some parameters are changed. By default, keep in R410A mode with switch OFF.

Defrosting (SW1-7):

By setting the switch to ON if the outside temperature drops below 10°C, a defrost is performed every 50 minutes. Otherwise, if the switch remains in OFF the defrost is done only when it is necessary according to the recorded temperatures.

Reserved (SW1-8):

Function not used. Keep switch in OFF position as default.

SW6 1=ON 0=OFF								Description
Address of centralized controller / bms								
SW6-8	SW6-7	SW6-6	SW6-5	SW6-4	SW6-3	SW6-2	SW6-1	
OFF	OFF	OFF	OFF	OFF	OFF	OFF	OFF	Address No. 1
OFF	OFF	OFF	OFF	OFF	OFF	OFF	ON	Address No. 2
OFF	OFF	OFF	OFF	OFF	OFF	ON	OFF	Address No. 3
OFF	OFF	OFF	OFF	OFF	OFF	ON	ON	Address No. 4
OFF	OFF	OFF	OFF	OFF	ON	OFF	OFF	Address No. 5
---	---	---	---	---	---	---	---	Address No. --
ON	ON	ON	ON	ON	ON	ON	ON	Address No. 128

SW7 1=ON 0=OFF		
SW7-1	SW7-2	Description
OFF	OFF	DERD test 0
OFF	ON	DERD test 1
ON	OFF	DERD test 2
ON	ON	DERD function disabled (DEFAULT)

SW8 (ROTARY)	
Model selection	
Position	Description
0	1UH071N1ERG
1	1UH090N1ERG
2	1UH105N1ERG
3	Not used
4	1UH125P1ERG
5	1UH140P1ERG
6	Not used
7	1UH160P1ERG
8	1UH125P1ERK
9	1UH140P1ERK
A	1UH200W1ERK
B	1UH250W1ERK
C	Not used
D	Not used
E	Not used
F	Not used

READING / FORCING PARAMETERS

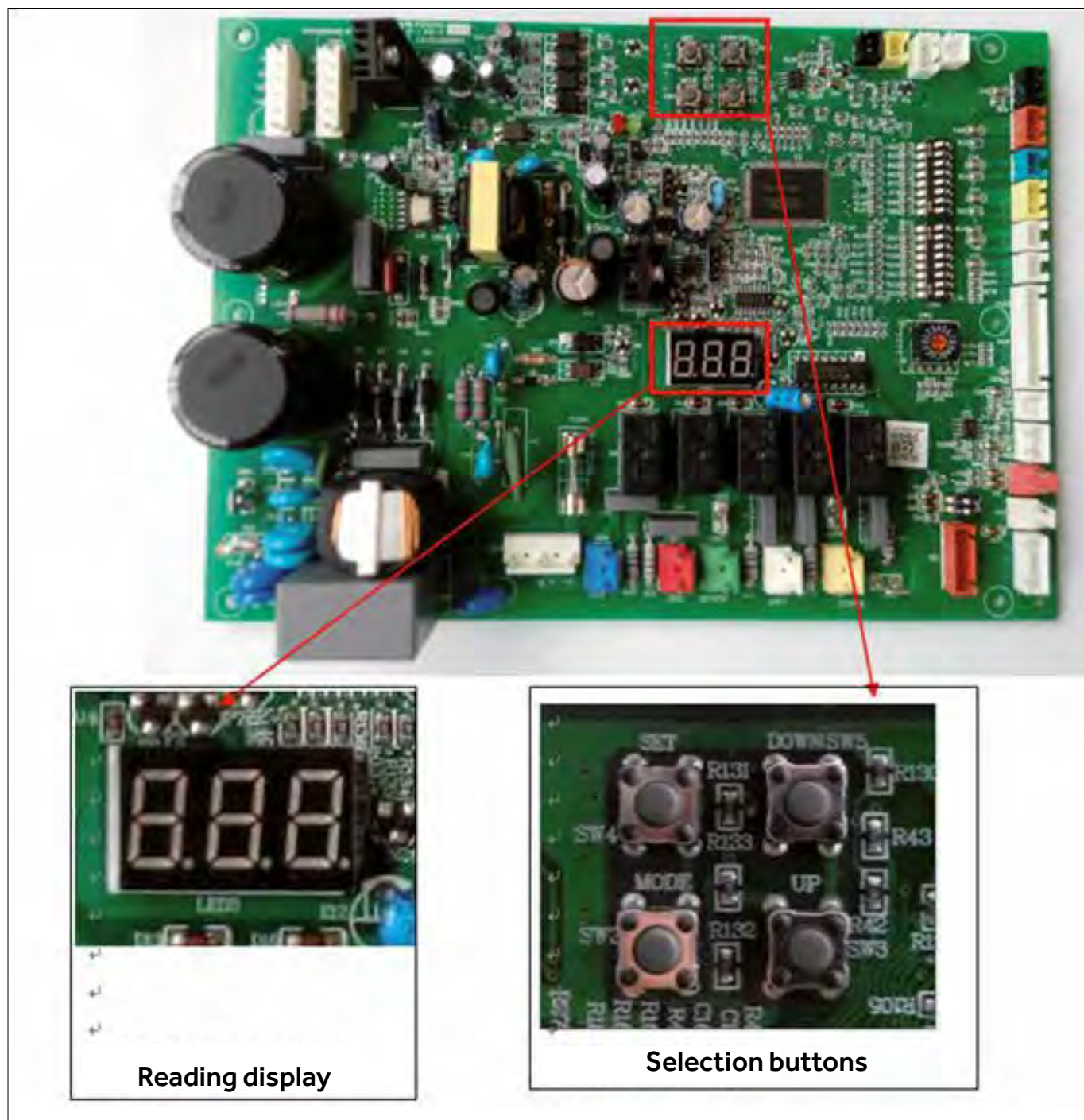

Parameters shown in the display

- As soon as the outdoor unit is powered, the corresponding power will appear in the display.

MODEL	MODEL CODE	DISPLAY
1UH071N1ERG	24.1	24.1
1UH090N1ERG	30.1	30.1
1UH105N1ERG	36.1	36.1
1UH125P1ERG	48.2	48.2
1UH140P1ERG	60.2	60.2
1UH125P1ERK	48.4	48.4
1UH140P1ERK	60.4	60.4

- After a few seconds, the number of indoor units connected will appear

Monosplit systems 1:1



Maxisplit systems with 2/3/4 indoor units

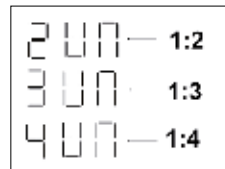

- As soon as the compressor starts, the startup mode will appear for a few seconds:
Coo: Cooling
HAE: Heating

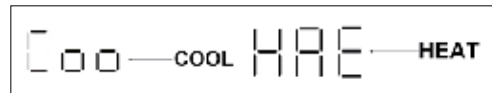

- After a few seconds, operating frequency of the compressor will appear in the display

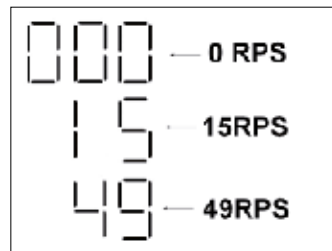

- As soon as the compressor is switched off, the off sign will appear for a few seconds, after which the display will remain off until the compressor restarts again.



Forced cooling:

- Using the electronic board of the outdoor unit, press the "MODE" (SW2) key for 5 seconds and flashing "Coo" will appear on the display.

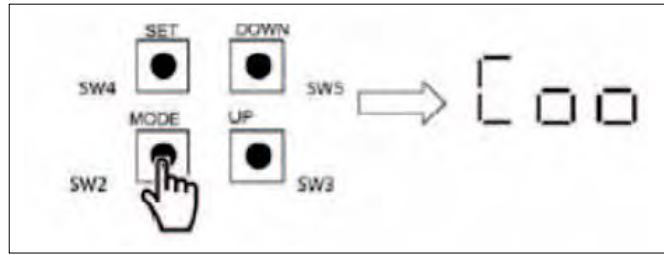

- Confirm by pressing the "SET" (SW4) key for 5 seconds.

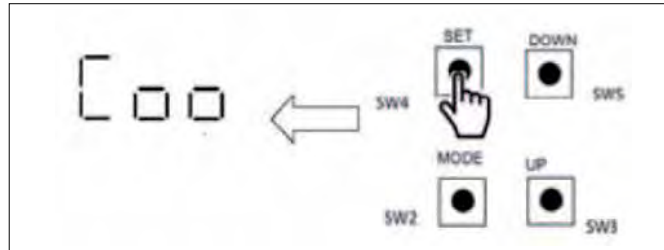

- Place switches 1 and 2 of the SW1 bank to "ON"
- From remote controller/wired controller turn on the indoor unit in cooling mode at 16°C with maximum ventilation. (*If the indoor unit remains off.)
- To turn off the outdoor unit, place the switches 1 and 2 of the SW1 bank back to "OFF".

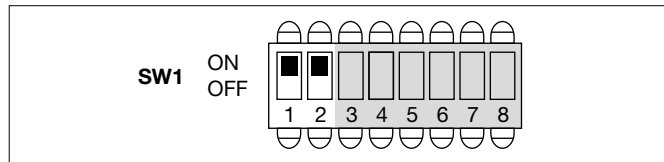

Forced heat pump:

- Using the electronic board of the outdoor unit, press the "MODE" (SW2) key for 5 seconds and flashing "Coo" will appear on the display.

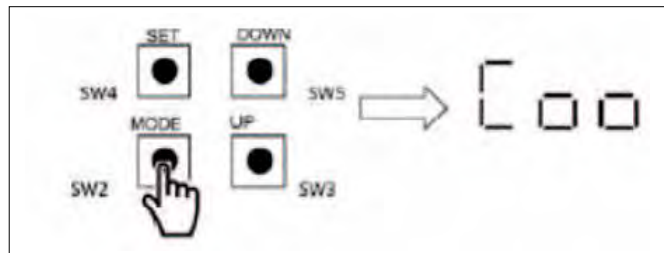

- Press the "UP" (SW3) key for 1 time and the flashing "HEA" appears in the display.

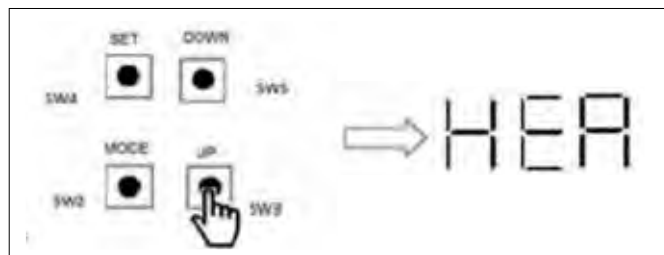

- Confirm by pressing the "SET" (SW4) key for 5 seconds.

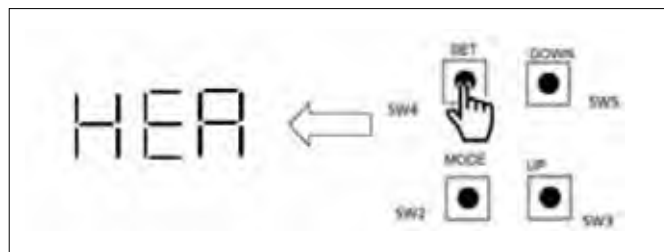

- Place switch 1 of the SW1 bank to "ON"
- From remote controller/wired controller turn on the indoor unit in heat pump mode at 30°C with maximum ventilation. (*If the indoor unit remains off.)
- To turn off the outdoor unit, place the switch 1 of the SW1 bank back to "OFF".

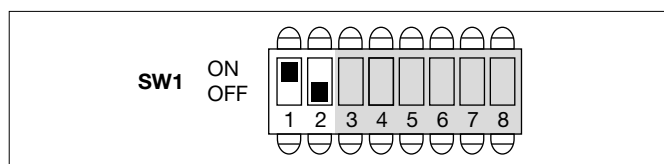

Parameter reading mode:

With this procedure it is possible to check some parameters, some of which can be "forced" in order to verify the actual functioning of the linked devices.

For read-only parameters, keep switch 1 of the SW1 bank in "OFF"

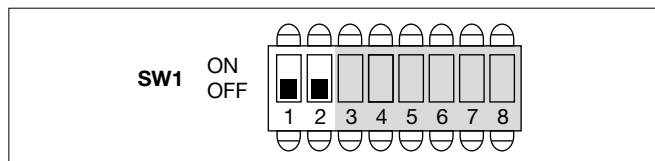

To force some parameters, instead, set the switch 1 of the SW1 bank to "ON".

****Once the verifications are complete, set the switch no. 1 to "OFF" again.**

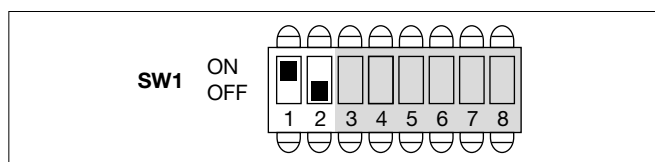





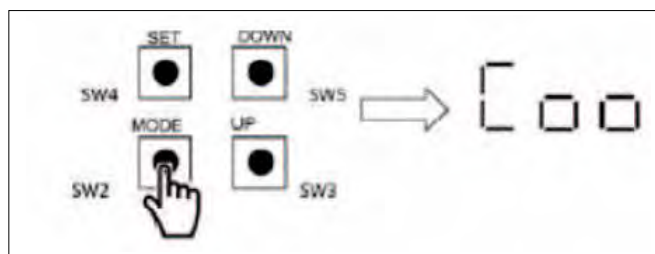







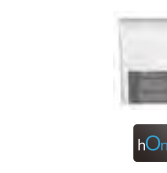

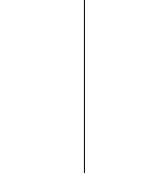
Raise the switch only when you have already selected the function you want to force

- Using the electronic board of the outdoor unit, press the "MODE" key for 5 seconds. "Coo" will flash on the display.
- Press the "UP" (SW3) key 5 times until "Off" appears in the display
- Press the "SET" (SW4) key for 5 seconds and the display will stop flashing.
- Press the "SET" (SW4) key again for 5 seconds, a second menu will appear in the display with the following functions:







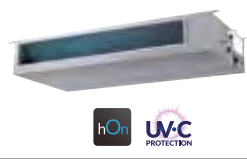

Abbreviation	Symbol	Description		Possibility of forcing (SW1, 1 "ON")
Frq	Frq	Compressor frequency	*	000 to 120 rps
opN	oPN	Electronic expansion valve opening	*	000 to 500
I.FN	I.FN	Indoor unit fan speed (002 to 004, 000 off)		
o.FN	o.FN	Outdoor unit fan speed	*	000 to 009
tAo	tAo	Outdoor unit ambient temperature		
tc	tc	Outdoor unit exchanger temperature		
td	td	Compressor delivery temperature		
tE	tE	Defrosting probe temperature		
tS	tS	Compressor intake temperature		
tdr	tdr	Power module temperature		
ldr	ldr	Current absorbed by compressor		
tH	tH	Hot water temperature (not used)		
tAI	tAI	Indoor unit ambient temperature		
TCI	TCI	Indoor unit exchanger temperature		
tSt	tSt	Indoor unit set temperature (in heat pump mode +3°C for compensation)		

- Press the "UP"(SW3) and "DOWN" (SW4) keys to scroll through the various functions. If the chosen function allows forcing, raise the switch 1 of the SW1 bank
- To exit the menu, press the "MODE" (SW2) key for 15 seconds, which will result in the word "Quit" appearing in the display. Confirm by holding down the "SET" (SW4) key for 5 seconds.

INDOOR UNITS (NEW VARIANT)		CASSETTE			CEILING/FLOOR CONVERTIBLE			
								
OUTDOOR UNITS		1:2	1:3	1:4	1:2	1:3	1:4	
10.5 kW		AB50S2SC2FA(H) AB50S2SC2FA(H)	AB35S2SC2FA(H) AB35S2SC2FA(H) AB35S2SC2FA(H)	AB25S2SC2FA(H) AB25S2SC2FA(H) AB25S2SC2FA(H)	AC50S2SG1FA(H) AC50S2SG1FA(H)	AC35S2SG1FA(H) AC35S2SG1FA(H) AC35S2SG1FA(H)		
	SINGLE-PHASE	1U105S2SS2FA	JOINT KIT FQG-2Y100A	JOINT KIT FQG-3Y100A + ADAPTER	JOINT KIT FQG-4Y200A + ADAPTER	JOINT KIT FQG-2Y100A	JOINT KIT FQG-3Y100A + ADAPTER	
THREE-PHASE	1U105S2SS1FB							
12.5 kW		AB71S2SG1FA(H) AB71S2SG1FA(H)	AB50S2SC2FA(H) AB50S2SC2FA(H) AB50S2SC2FA(H)	AB35S2SC2FA(H) AB35S2SC2FA(H) AB35S2SC2FA(H)	AC71S2SG1FA(H) AC71S2SG1FA(H)	AC50S2SG1FA(H) AC50S2SG1FA(H) AC50S2SG1FA(H)	AC35S2SG1FA(H) AC35S2SG1FA(H) AC35S2SG1FA(H)	
	SINGLE-PHASE	1U125S2SN2FA	JOINT KIT FQG-2Y200A + ADAPTER	JOINT KIT FQG-3Y200A + ADAPTER	JOINT KIT FQG-4Y200A + ADAPTER	JOINT KIT FQG-2Y200A + ADAPTER	JOINT KIT FQG-3Y200A + ADAPTER	JOINT KIT FQG-4Y200A + ADAPTER
THREE-PHASE	1U125S2SN2FB							
14.0 kW		AB71S2SG1FA(H) AB71S2SG1FA(H)	AB50S2SC2FA(H) AB50S2SC2FA(H) AB50S2SC2FA(H)	AB35S2SC2FA(H) AB35S2SC2FA(H) AB35S2SC2FA(H)	AC71S2SG1FA(H) AC71S2SG1FA(H)	AC50S2SG1FA(H) AC50S2SG1FA(H) AC50S2SG1FA(H)	AC35S2SG1FA(H) AC35S2SG1FA(H) AC35S2SG1FA(H)	
	SINGLE-PHASE	1U140S2SN1FA	JOINT KIT FQG-2Y200A + ADAPTER	JOINT KIT FQG-3Y200A + ADAPTER	JOINT KIT FQG-4Y200A + ADAPTER	JOINT KIT FQG-2Y200A + ADAPTER	JOINT KIT FQG-3Y200A + ADAPTER	JOINT KIT FQG-4Y200A + ADAPTER
THREE-PHASE	1U140S2SN1FB							
14.0 kW		AB71S2SG1FA(H) AB71S2SG1FA(H)	AB50S2SC2FA(H) AB50S2SC2FA(H) AB50S2SC2FA(H)	AB35S2SC2FA(H) AB35S2SC2FA(H) AB35S2SC2FA(H)	AC71S2SG1FA(H) AC71S2SG1FA(H)	AC50S2SG1FA(H) AC50S2SG1FA(H) AC50S2SG1FA(H)	AC35S2SG1FA(H) AC35S2SG1FA(H) AC35S2SG1FA(H)	
	SINGLE-PHASE	1U140S2SP2FA	JOINT KIT FQG-2Y200A + ADAPTER	JOINT KIT FQG-3Y200A + ADAPTER	JOINT KIT FQG-4Y200A + ADAPTER	JOINT KIT FQG-2Y200A + ADAPTER	JOINT KIT FQG-3Y200A + ADAPTER	JOINT KIT FQG-4Y200A + ADAPTER
THREE-PHASE	1U140S2SP2FB							
16.0 kW		AB71S2SG1FA(H) AB71S2SG1FA(H)	AB50S2SC2FA(H) AB50S2SC2FA(H) AB50S2SC2FA(H)	AB35S2SC2FA(H) AB35S2SC2FA(H) AB35S2SC2FA(H)	AC71S2SG1FA(H) AC71S2SG1FA(H)	AC50S2SG1FA(H) AC50S2SG1FA(H) AC50S2SG1FA(H)	AC35S2SG1FA(H) AC35S2SG1FA(H) AC35S2SG1FA(H)	
	THREE-PHASE	1U160S2SP1FB	JOINT KIT FQG-2Y200A + ADAPTER	JOINT KIT FQG-3Y200A + ADAPTER	JOINT KIT FQG-4Y200A + ADAPTER	JOINT KIT FQG-2Y200A + ADAPTER	JOINT KIT FQG-3Y200A + ADAPTER	JOINT KIT FQG-4Y200A + ADAPTER
CONTROLLERS AND ACCESSORIES		WIRED CONTROLLERS (REQUIRED FOR SYSTEM)						
								
		HW-BA101ABT	HW-BA116ABK	HW-SA201ABK	YR-E16B	HW-SA201ABK		

The data on this catalogue is purely indicative as the data may vary. Please be advised to check the accuracy of the data with the supplier before purchasing products.

INDOOR UNITS (NEW VARIANT)		SLIM DUCTED LOW PRESSURE 40 Pa			DUCTED MEDIUM PRESSURE 150 Pa		
							
OUTDOOR UNITS		1:2	1:3	1:4	1:2	1:3	1:4
10.5 kW		AD50S2SS1FA(H) AD50S2SS1FA(H)	AD35S2SS1FA(H) AD35S2SS1FA(H) AD35S2SS1FA(H)		AD50S2SM3FA(H) AD50S2SM3FA(H)	AD35S2SM3FA(H) AD35S2SM3FA(H) AD35S2SM3FA(H)	
	SINGLE-PHASE THREE-PHASE	1U10S2SS2FA 1U10S2SS1FB	JOINT KIT FQG-2Y100A	JOINT KIT FQG-3Y100A + ADAPTER		JOINT KIT FQG-2Y100A	JOINT KIT FQG-3Y100A + ADAPTER
12.5 kW		AD71S2SS1FA(H) AD71S2SS1FA(H)	AD50S2SS1FA(H) AD50S2SS1FA(H) AD50S2SS1FA(H)	AD35S2SS1FA(H) AD35S2SS1FA(H) AD35S2SS1FA(H) AD35S2SS1FA(H)	AD71S2SM3FA(H) AD71S2SM3FA(H)	AD50S2SM3FA(H) AD50S2SM3FA(H) AD50S2SM3FA(H)	AD35S2SM3FA(H) AD35S2SM3FA(H) AD35S2SM3FA(H)
	SINGLE-PHASE THREE-PHASE	1U12S2SN2FA 1U12S2SN2FB	JOINT KIT FQG-2Y200A + ADAPTER	JOINT KIT FQG-3Y200A + ADAPTER	JOINT KIT FQG-4Y200A + ADAPTER	JOINT KIT FQG-2Y200A + ADAPTER	JOINT KIT FQG-3Y200A + ADAPTER
14.0 kW		AD71S2SS1FA(H) AD71S2SS1FA(H)	AD50S2SS1FA(H) AD50S2SS1FA(H) AD50S2SS1FA(H)	AD35S2SS1FA(H) AD35S2SS1FA(H) AD35S2SS1FA(H) AD35S2SS1FA(H)	AD71S2SM3FA(H) AD71S2SM3FA(H)	AD50S2SM3FA(H) AD50S2SM3FA(H) AD50S2SM3FA(H)	AD35S2SM3FA(H) AD35S2SM3FA(H) AD35S2SM3FA(H)
	SINGLE-PHASE THREE-PHASE	1U140S2SN1FA 1U140S2SN1FB	JOINT KIT FQG-2Y200A + ADAPTER	JOINT KIT FQG-3Y200A + ADAPTER	JOINT KIT FQG-4Y200A + ADAPTER	JOINT KIT FQG-2Y200A + ADAPTER	JOINT KIT FQG-3Y200A + ADAPTER
14.0 kW		AD71S2SS1FA(H) AD71S2SS1FA(H)	AD50S2SS1FA(H) AD50S2SS1FA(H) AD50S2SS1FA(H)	AD35S2SS1FA(H) AD35S2SS1FA(H) AD35S2SS1FA(H) AD35S2SS1FA(H)	AD71S2SM3FA(H) AD71S2SM3FA(H)	AD50S2SM3FA(H) AD50S2SM3FA(H) AD50S2SM3FA(H)	AD35S2SM3FA(H) AD35S2SM3FA(H) AD35S2SM3FA(H)
	SINGLE-PHASE THREE-PHASE	1U140S2SP2FA 1U140S2SP2FB	JOINT KIT FQG-2Y200A + ADAPTER	JOINT KIT FQG-3Y200A + ADAPTER	JOINT KIT FQG-4Y200A + ADAPTER	JOINT KIT FQG-2Y200A + ADAPTER	JOINT KIT FQG-3Y200A + ADAPTER
16.0 kW		AD71S2SS1FA(H) AD71S2SS1FA(H)	AD50S2SS1FA(H) AD50S2SS1FA(H) AD50S2SS1FA(H)	AD35S2SS1FA(H) AD35S2SS1FA(H) AD35S2SS1FA(H) AD35S2SS1FA(H)	AD71S2SM3FA(H) AD71S2SM3FA(H)	AD50S2SM3FA(H) AD50S2SM3FA(H) AD50S2SM3FA(H)	AD35S2SM3FA(H) AD35S2SM3FA(H) AD35S2SM3FA(H)
	THREE-PHASE	1U160S2SP1FB	JOINT KIT FQG-2Y200A + ADAPTER	JOINT KIT FQG-3Y200A + ADAPTER	JOINT KIT FQG-4Y200A + ADAPTER	JOINT KIT FQG-2Y200A + ADAPTER	JOINT KIT FQG-3Y200A + ADAPTER
CONTROLLERS AND ACCESSORIES		CENTRALIZED CONTROLS (OPTIONAL)					
							
		HC-SA164DBT					

The data on this catalogue is purely indicative as the data may vary. Please be advised to check the accuracy of the data with the supplier before purchasing products.

COLLECTOR SPECIFICATIONS						
OUTDOOR UNITS	INDOOR UNITS	N° IU	WIRED CONTROLLER	GAS	LIQUID	JOINT
1U105S2SS2FA 1U105S2SS1FB	AB50S2SC2FA(H) AC50S2SG1FA(H) AD50S2SS1FA(H) AD50S2SM3FA(H)	2	YR-E17A			FQG-2Y100A
1U125S2SN2FA 1U125S2SN2FB 1U140S2SN1FA 1U140S2SN1FB 1U140S2SP2FA 1U140S2SP2FB 1U160S2SP1FB	AB71S2SG1FA(H) AC71S2SG1FA(H) AD71S2SS1FA(H) AD71S2SM3FA(H)	2	YR-E17A			FQG-2Y200A
1U105S2SS2FA 1U105S2SS1FB	AB35S2SC2FA(H) AC35S2SG1FA(H) AD35S2SS1FA(H) AD35S2SM3FA(H)	3	YR-E17A			FQG-3Y100A
1U125S2SN2FA 1U125S2SN2FB 1U140S2SN1FA 1U140S2SN1FB 1U140S2SP2FA 1U140S2SP2FB 1U160S2SP1FB	AB50S2SC2FA(H) AC50S2SG1FA(H) AD50S2SS1FA(H) AD50S2SM3FA(H)	3	YR-E17A			FQG-3Y200A
1U105S2SS2FA 1U105S2SS1FB 1U125S2SN2FA 1U125S2SN2FB 1U140S2SN1FA 1U140S2SN1FB 1U140S2SP2FA 1U140S2SP2FB 1U160S2SP1FB	AB25S2SC2FA(H) AB35S2SC2FA(H) AC35S2SG1FA(H)	4	YR-E17A			FQG-4Y200A
1U125S2SN2FA 1U125S2SN2FB 1U140S2SN1FA 1U140S2SN1FB 1U140S2SP2FA 1U140S2SP2FB 1U160S2SP1FB	AD25S2SS1FA(H) AD35S2SS1FA(H) AD35S2SM3FA(H)	4	YR-E17A			FQG-4Y200A

The data on this catalogue is purely indicative as the data may vary. Please be advised to check the accuracy of the data with the supplier before purchasing products.

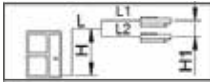
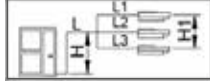
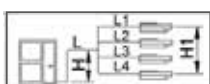
PIPE SPECIFICATIONS																												
No. IU	Pipe diagram	Maximum pipe length (m)			Height difference max OU - IU (m)			Maximum single IU length (m)			Max IU - IU height difference (m)			Max pipe length difference (m)			Pipe diameter (mm)				Joints diameter (mm)							
2		L+L1+L2			H			L1 or L2			H1			L1-L2			liquid/gas				liquid/gas							
		Outdoor units			Outdoor units			Outdoor units			Outdoor units			Outdoor units			Outdoor units				Outdoor units							
		105	125	140 160	105	125	140 160	105	125	140 160	105	125	140 160	105	125	140 160	105	125	140 160	105	125	140 160	105	125	140 160	105	125	140 160
		≤50	≤75		≤30			≤20			≤0.5			≤10			9.52 15.88		9.52 19.05		9.52	9.52	15.88	15.88				
3		L+L1+L2+L3			H			L1 or L2 or L3			H1			(Lx-Ly) x,y=1,2,3 x≠y			liquid/gas				liquid/gas							
		Outdoor units			Outdoor units			Outdoor units			Outdoor units			Outdoor units			Outdoor units				Outdoor units							
		105	125	140 160	105	125	140 160	105	125	140 160	105	125	140 160	105	125	140 160	105	125	140 160	105	125	140 160	105	125	140 160	105	125	140 160
		≤50	≤60	≤75	≤20	≤30		≤20			≤0.5			≤10			9.52 15.88		9.52 19.05		6.35	6.35	6.35	9.52	12.7	12.7		
4		L+L1+L2+L3+L4			H			L1 or L2 or L3 or L4			H1			(Lx-Ly) x,y=1,2,3,4 x≠y			liquid/gas				liquid/gas							
		Outdoor units			Outdoor units			Outdoor units			Outdoor units			Outdoor units			Outdoor units				Outdoor units							
		105	125	140 160	105	125	140 160	105	125	140 160	105	125	140 160	105	125	140 160	105	125	140 160	105	125	140 160	105	125	140 160	105	125	140 160
		≤50	≤60	≤75	≤20	≤30		≤20			≤0.5			≤10			9.52 15.88		9.52 19.05		6.35	6.35	6.35	9.52	9.52	9.52		

CIRCUIT DIAGRAM

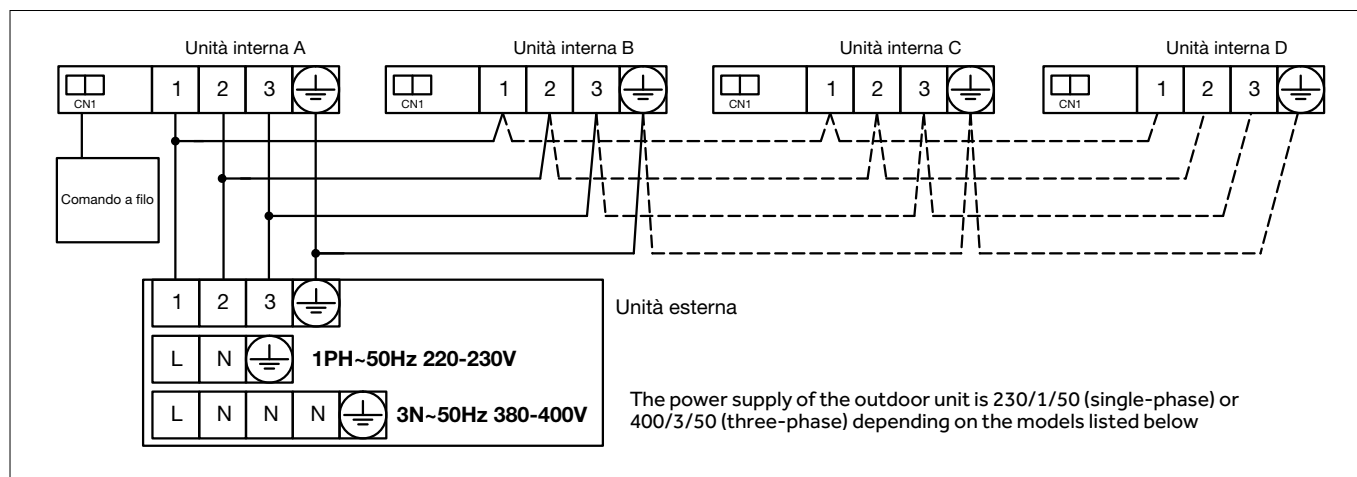

DIAGNOSTICS:

To see the list of alarms of indoor / outdoor units in combination MAXISPLIT, go to page 34

SETTINGS:

Indoor units

- Cassette (620) on **page XX**
- Round flow cassette on **page XX**
- Ceiling / Floor Convertible on **page XX**
- Ducted Low Pressure on **page XX**
- Ducted Medium Pressure on **page XX**

Outdoor units

- (10.5 kW - 12.5 kW - 14 kW) (single-phase) on **page XX**
- (12.5 kW - 14 kW) (three-phase) on **page XX**
- (16 kW) (three phase) on **page XX**

CENTRALISED CONTROLLER

HC-SA164DBT	152
YR-E16B	158
HW-BA116ABK	161
HW-BA101ABT	165

TEMPERATURE PROBES

Temperature Probes	168
---------------------------	-----

USER INTERFACE

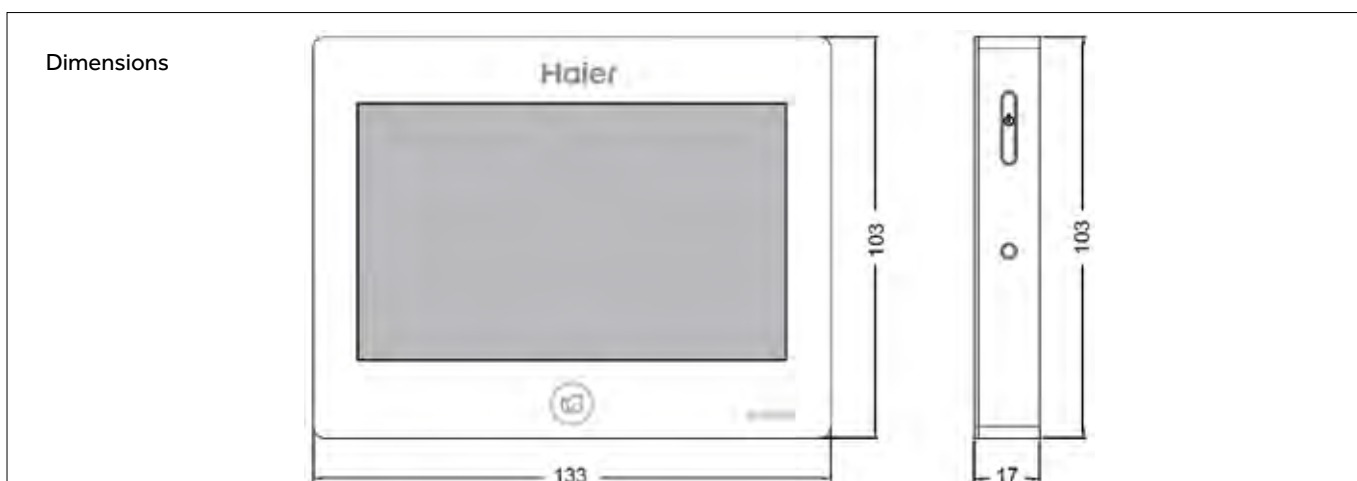
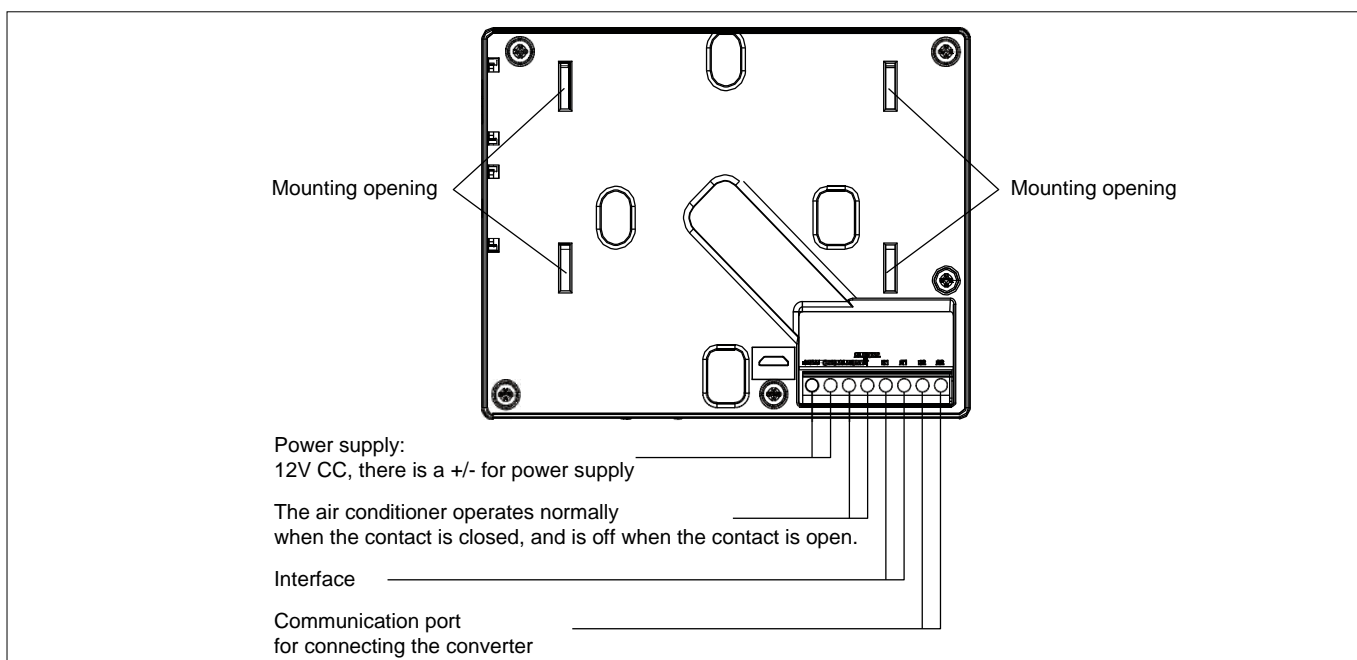

OPERATION

Parameters and control of indoor units

To see the settings for each indoor unit, touch the Air Conditioner icon.

The figure shows the On/Off, Mode, Set Temperature, Ambient Temperature, Fan Speed, and Control Mode icons for connected indoor units.

- Automatic mode - dark blue
- Cooling mode - blue
- Heating mode - orange
- Dehumidification mode - purple
- Fan mode - green
- Indoor unit turned off - gray

In the event of an indoor unit failure, the ERROR icon appears on the centralised controller.

Access the following interface: the icons show the indoor switch, mode, set temperature, ambient temperature, airflow speed, and control mode.

Dark blue indicates automatic mode, blue indicates cooling, orange indicates heating, purple indicates dehumidification, green indicates airflow and gray indicates off.

In the event of a failure, the error icon is displayed.

The current number of indoor units.
If all existing indoor units fail, you can scroll up and down for viewing.
You can click on the second icon below to select the indoor units you want to display. 🔍

Time: You can adjust the time using "Home-Setting-Time"

Click to return to Home

Click to select the indoor units you want to view

Click to view the checklist.

List view interface

Display interface icons

Service (Maintenance)

Press the "Service" key and the "Confirm" key in the pop-up window that prompts you to enter your password.

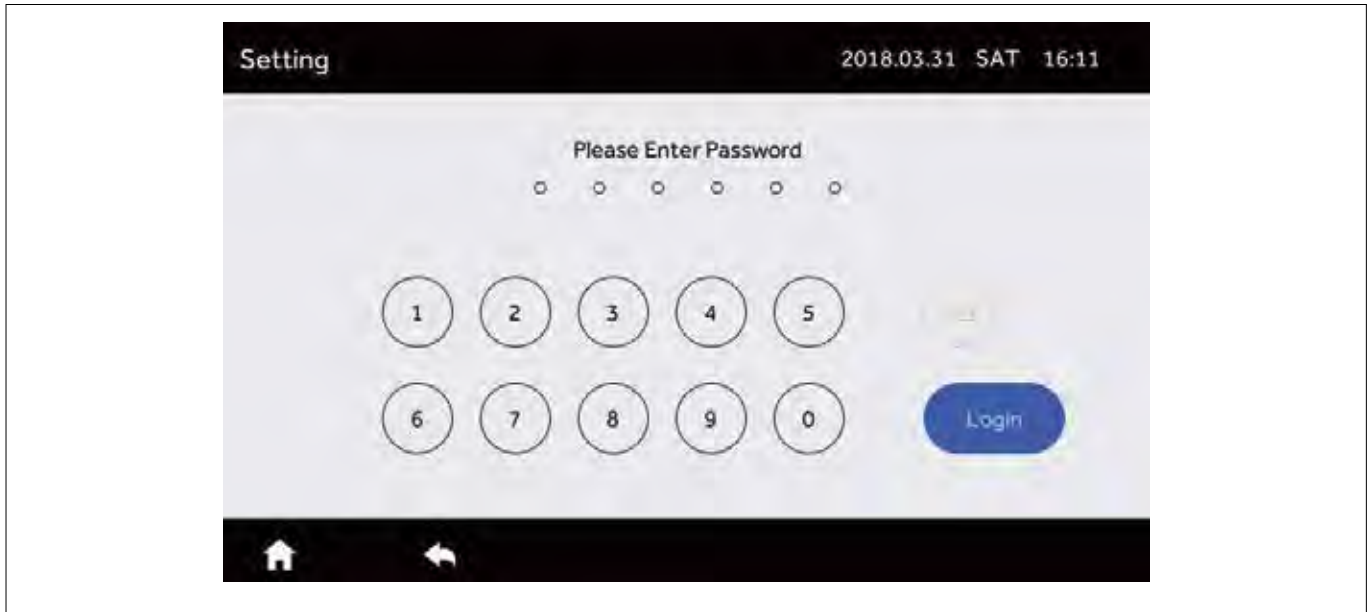

Enter the password 841226 and press "Login".

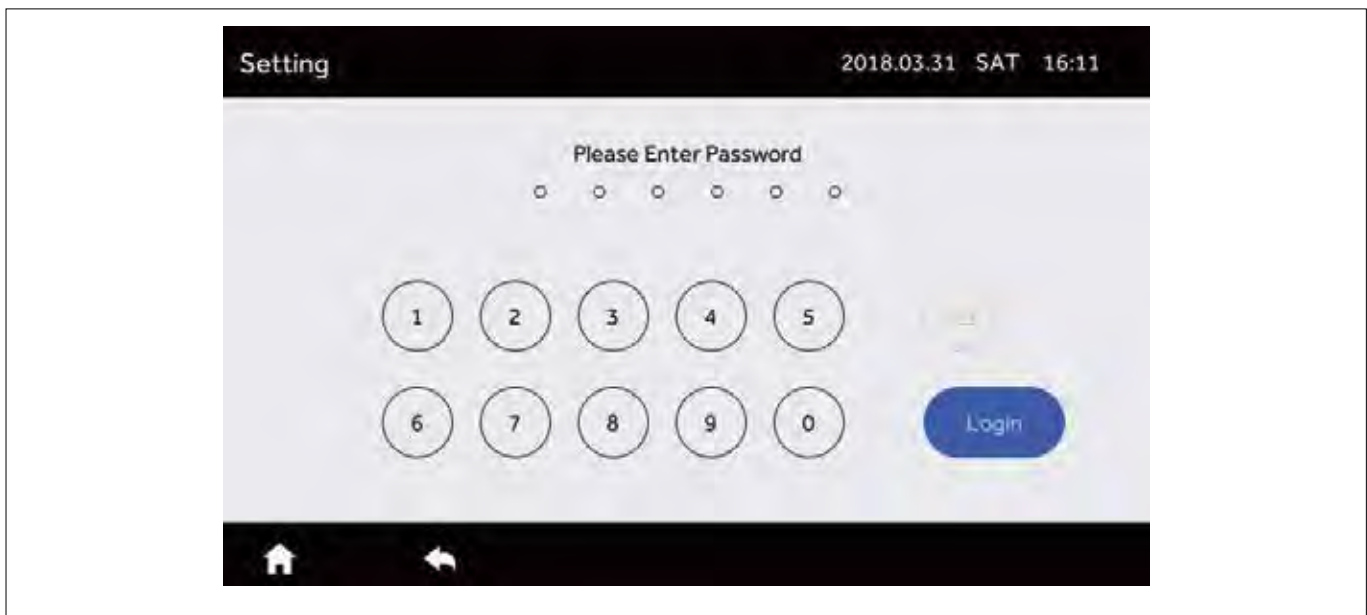

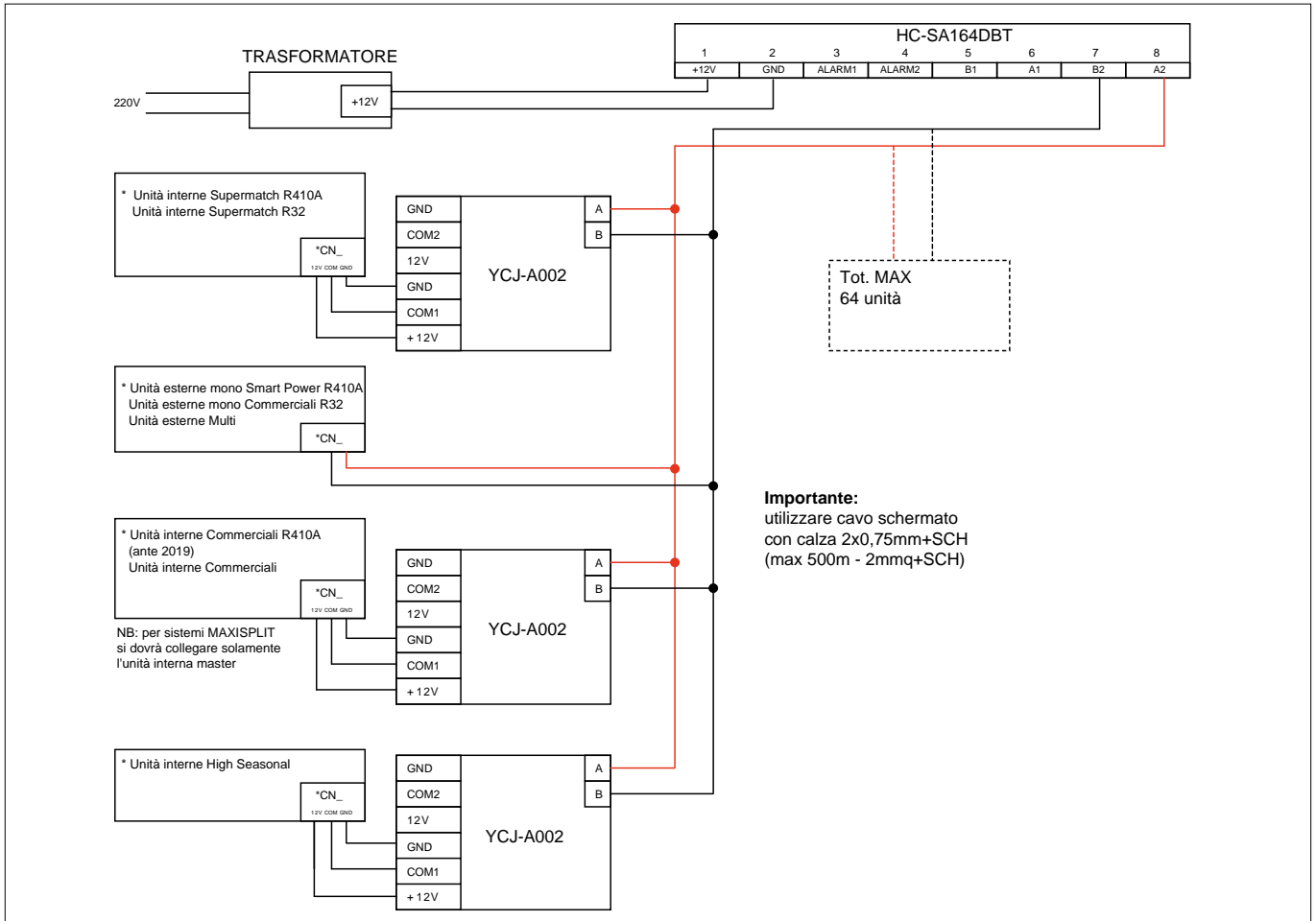

Wall	Connector
AS__S2SJ1FA-3	CN36
AS__PBAHRA	CN36
AS__PDAHRA	CN36
AS__THMHRA-C	CN36
HEC__T0-IN-M	CN36
HAS__FAAIN	CN36
HAS09TAAIN	CN36
CY__FAIN	CN36
CY-09TAIN - CY-12TAIN	CN36
CY__TAIN-M	CN36
AS__S2SF2FA-3	CN36
AS__TAEHRA(M)	CN36
AS__XCHHRA-NR	CN36
AS__XCAHRA-MB	CN36
AS__XCAHRA	CN36
Cassette	Connector
AB__S2SC2FA-1	CN13
ABH__H1ERG	CN13
ABH__K1ERG	CN13
AB__S2SG1FA	CN13
AB__S2SC2FA(H)	CN13
AB__S2SG1FA(H)	CN13
ABH__H1ERG(H)	CN13
Console	Connector
AF__S2SD1FA(H)	CN13
AF__S2SD1FA(D)	CN13
Tower	Connector
AP__S2SK1FA(H)	CN13

Ceiling-Floor Convertible	Connector
AC__S2SG1FA	CN13
AC__S2SH1FA	CN13
AC__S2SK1FA	CN13
AC__S2SG1FA(H)	CN13
AC__S2SH1FA(H)	CN13
Ducted	Connector
AD__S2SS1FA(H)	CN9
AD__S2SM3FA(H)	CN9
AD140S2SM3FA - AD125S2SM3FA	CN19
AD160S2SM3FA	CN9
ADH200H1ERG - ADH250H1ERG	CN19
ADH125H1ERG - ADH140H1ERG	CN24
AD__S2SM8FA(H)	CN4
Outdoor Mono	Connector
1UH__W1ERK	CN10
1U__S2SN2FA	CN31
1U__S2SN2FB	CN31
1U__S2SN1FA	CN31
1U__S2SN1FB	CN31
1U__S2SP2FA	CN10
1U__S2SP1FB	CN31
Outdoor Multi	Connector
H3U__TAAOUT	CN4
3U__S2SR5FA	CN4
4U__S2SR5FA	CN4
5U__S2SS5FA	CN4
5U__S2SS5FA	CN4
5U__S2SN1FA	CN3

Connecting the HI-WA164DBI Wi-Fi module to the centralized controller

HI-WA164DBI



Basic functions of the centralized HC-SA164DBT can be remotely controlled with the HI-WA164DBI Wi-Fi interface.
(To download the application go to page 261)

Connection diagram for HC-SA164DBT

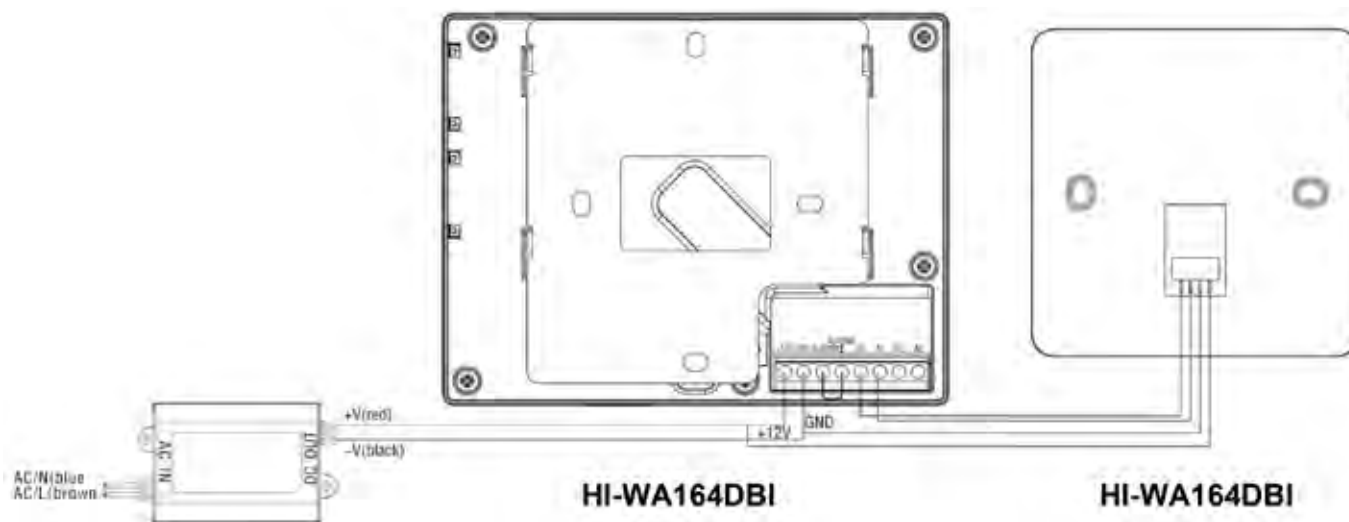

UNIT ADDRESS SETTINGS (to be set using switches on the YCJ-A002 interface)

SW01	DESCRIPTION	SW01	DESCRIPTION
	1		7
	2		8
	3		9
	4		10
	5		16
	6		128

LEDs 1 and 3 on the YCJ-A002 interface indicate proper communication by blinking quickly.

CONNECTING MULTI 1:3 1:4 1:5 OUTDOOR UNITS TO A HC-SA164DBT CENTRALISED CONTROLLER

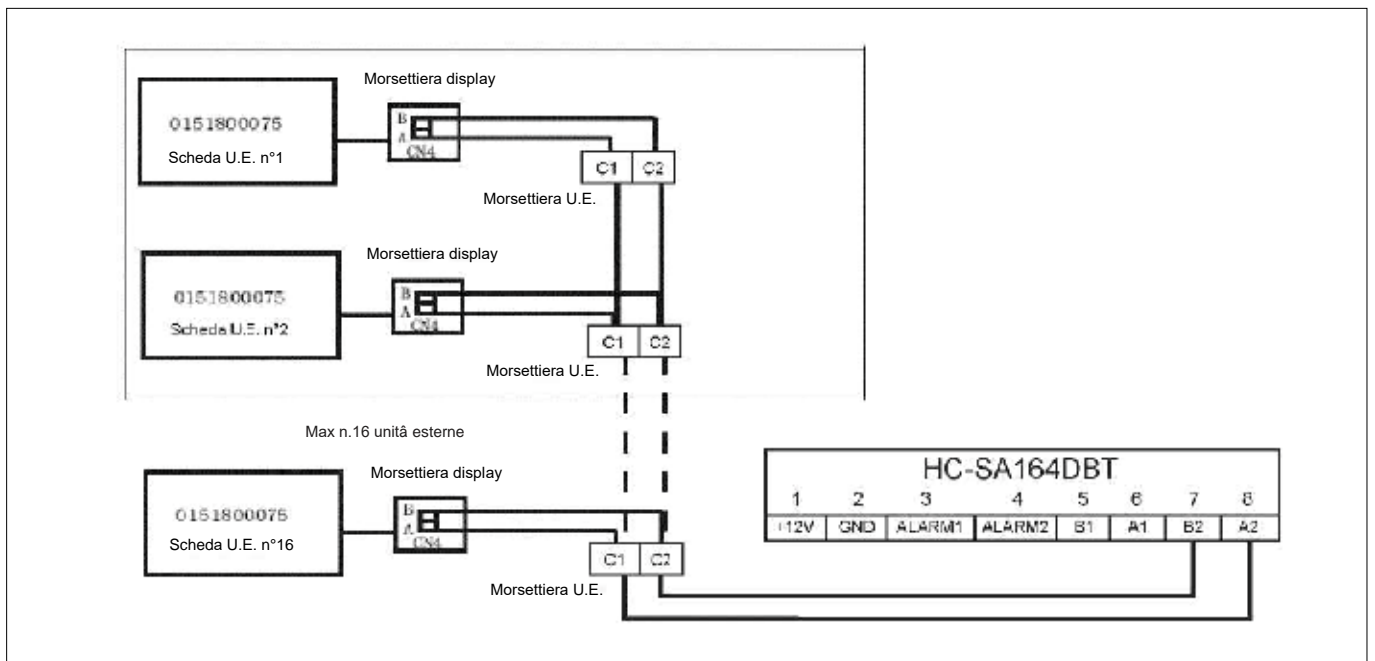

With each HC-SA164DBT centralized controller, up to 12 outdoor units can be connected, where each outdoor unit indiscriminately occupies 5 addresses in the centralized controller.







Use shielded cable (2x0.75 mmq) for the connection between centralized controller and outdoor units
Maximum system length 500 m (2x1.5 mmq shielded).

For setting addresses, refer to:

- page 88 for multi unit in R32

USER INTERFACE



KEYS	
	Left cursor: Selects operating mode on the main screen, serves as "back" key in other screens.
	Selects "smart" operating mode.
	Left/right, selects fan speed, adjusts deflector position on main screen, moves cursor.
	High/low, temperature adjustment set on the main screen, move cursor, and change values.
	Selects menu on the main screen, confirmation key.
	Right cursor: Selects deflectors on the main screen, serves as "return to main menu" key in other screens. Ventilator speed selection when the deflector oscillation function is not set.
	On/Off

1. Error code

Press enter in the alarm signalling icon.

- The UP and DOWN keys select the unit, the RIGHT and LEFT keys change the page.
- Only one current alarm is visible while up to 35 historical alarms can be displayed.
- Press the left and right keys at the same time for 5 seconds to clear the error history of the current unit. Press the up and down keys simultaneously for 5 seconds to clear the history of all online units.

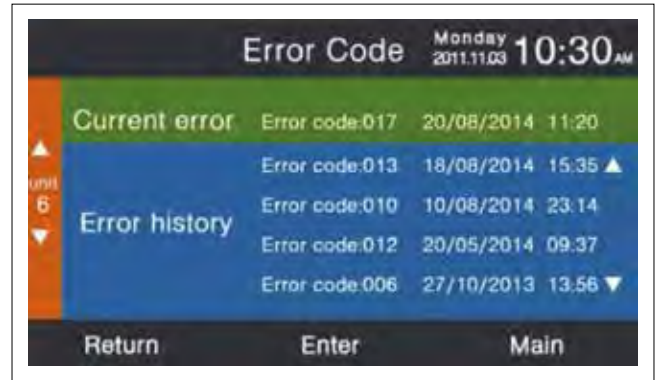

2. Password recovery

- Press enter in the alarm signalling icon.
- Press enter in the service icon
- The password feature includes the password setting and password recovery. The default code is 841226.



- If you have set up password recovery, the following screen will appear with cancel or confirm options.
- The recovery function is reserved only for some models. The information is gray when it is not selectable.



ELECTRICAL WIRING INSTRUCTIONS

1. First, put the communication cable through the hole of the back cover.
2. Connect the communication cable to the CON4 connector. Then put the front cover back on.

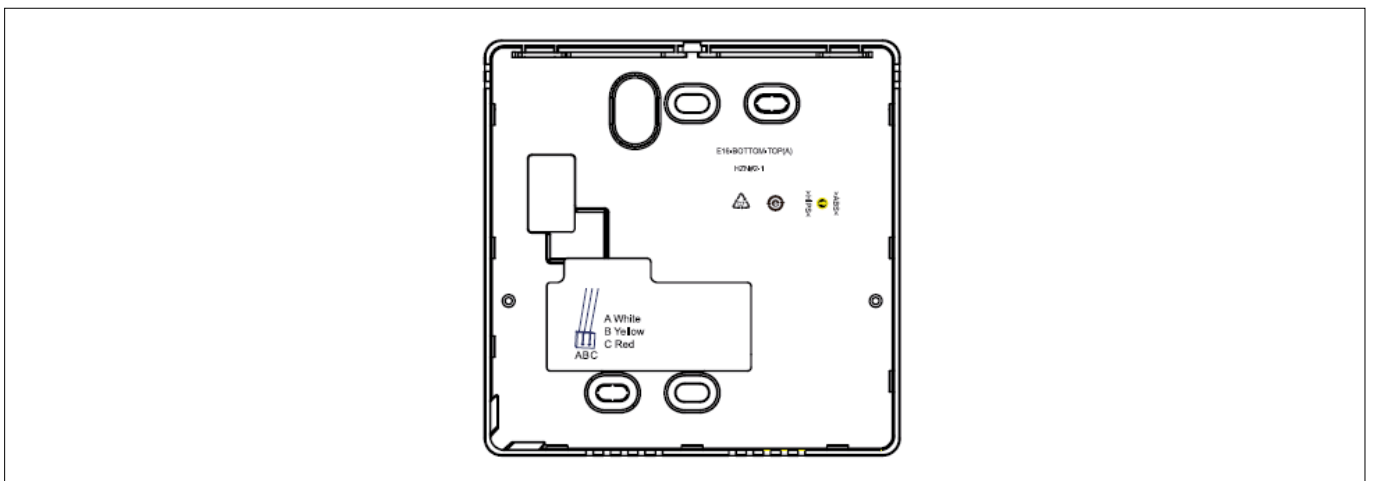

CONTROLLER WIRING

Electrical connections

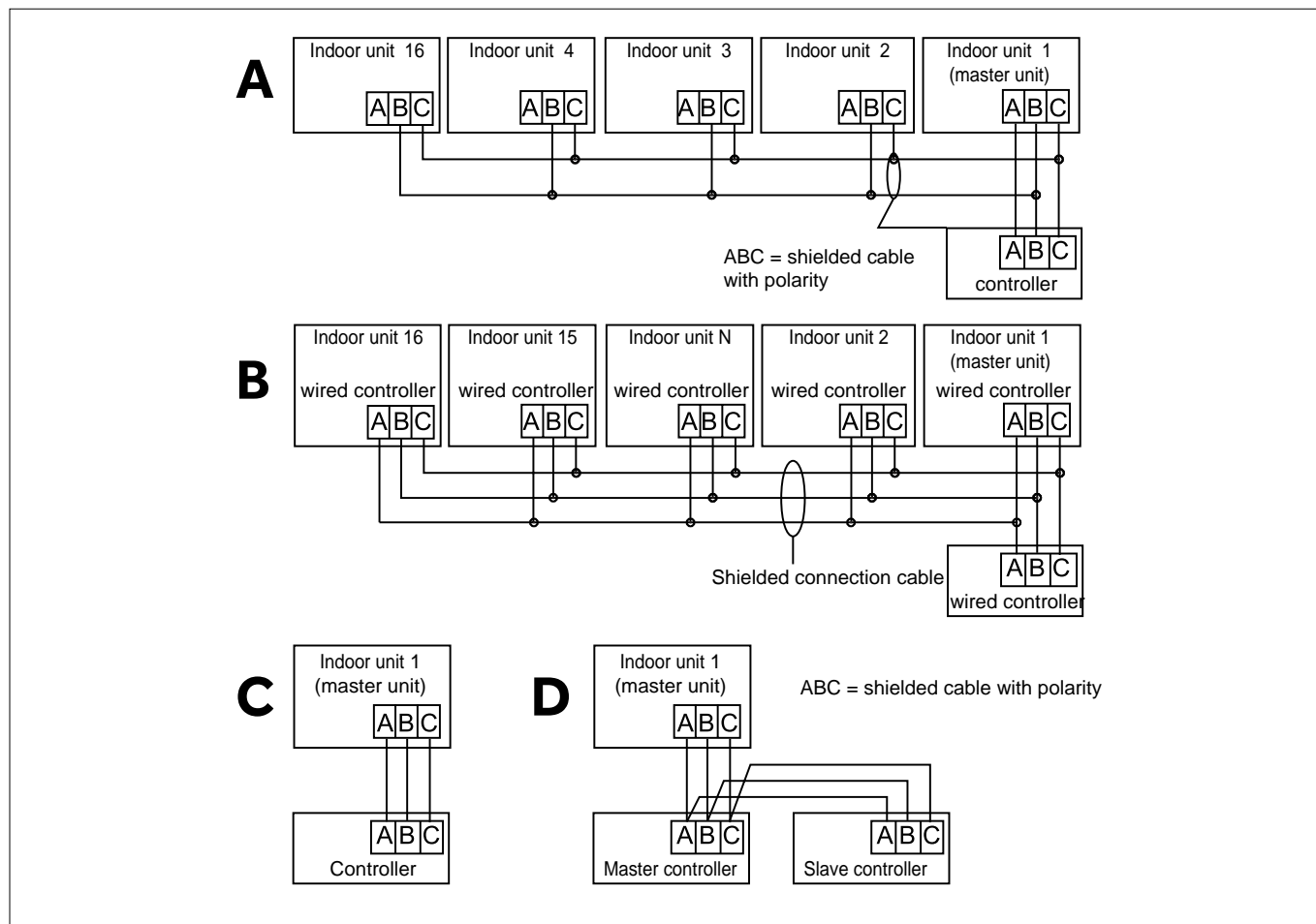

There are four methods to connect the wired controller with the indoor units.

- A. **(For boards with outdoor transformer)** a single wired controller can control up to 16 indoor units. The wired controller will be connected via a three-conductor polarized shielded cable (A-B-C) to the first indoor unit that will be addressed as "Master" (refer to the indoor unit board settings), while the other indoor units will be connected by a cable with only two conductors (B-C).
- B. **(For boards with transformer on board)** same conditions as case A, but all indoor units will be connected by the same cable with three conductors (A-B-C).
- C. A wired controller controls a single indoor unit via a polarized three-conductor shielded cable (A-B-C)
- D. Two wired controllers control a single indoor unit. The first wired controller, set as "Master" (SW1-OFF) is connected with the indoor unit and the second wired controller set as "Slave" (SW1-ON) via a polarized three-conductor shielded cable (A-B-C).

A-B-C communication cable specifications	
Cable length (m)	Cable section
<100	3x0.5mm ² + SCH*
≥100 and <200	3x0.5mm ² + SCH*
≥200 and <300	3x0.75 mm ² + SCH*
≥300 and <400	3x1.5 mm ² + SCH*
≥400 and <500	3x2 mm ² + SCH*

*connect only one end of the screen to ground.

DISPLAY INTERFACE

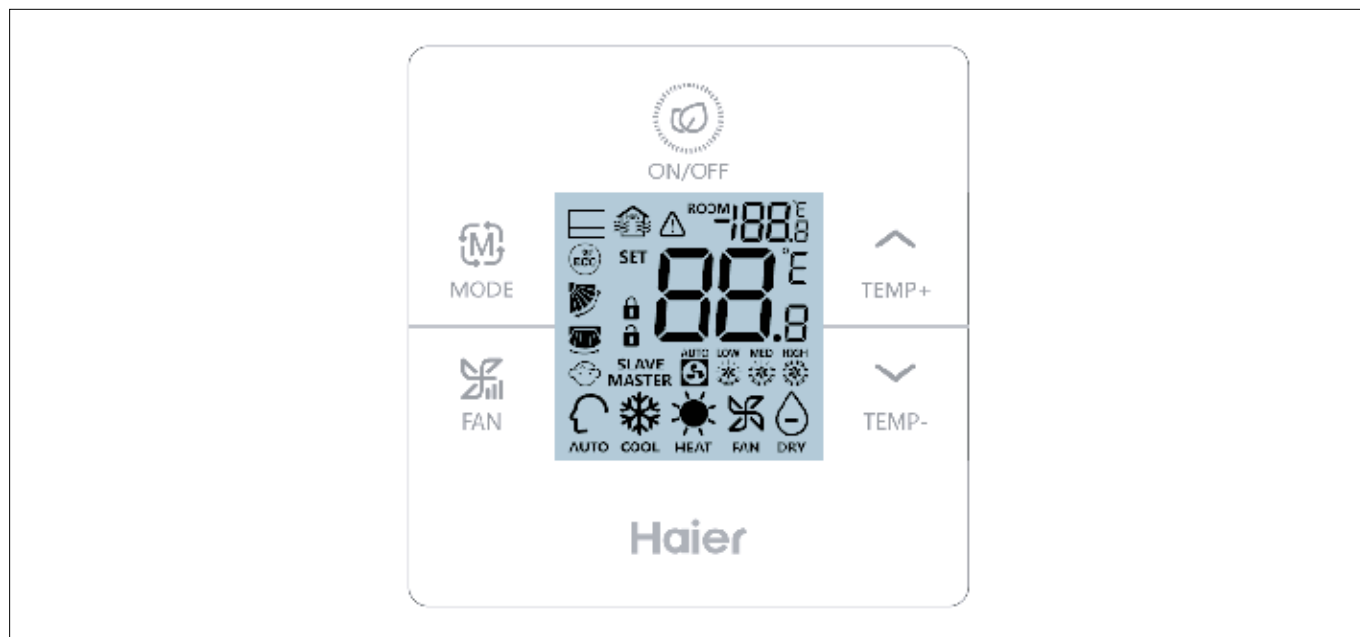

OPERATION













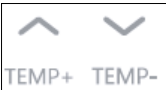

Meaning SW1 Selection Dip Switches

The selection switches are located on the electronic board in the rear of the controller.

SW1	ON	OFF	Default
SW1-1	Wired controller slave	Wired controller master	OFF
SW1-2	Room temperature display	No room temperature display	OFF
SW1-3	Ambient temperature detection from indoor unit probe	Detection of ambient temperature from Wired controller	OFF
SW1-4	Restart after power failure disabled	Restart after power failure enabled	OFF
SW1-5	Old protocol (models developed before August 2013)	New protocol	OFF
SW1-6	Backlight always on	Backlight on for 15 seconds in idle conditions.	OFF
SW1-7	Inclination UP/DOWN + inclination LEFT/RIGHT	Inclination UP/DOWN	OFF
SW1-8	Reserved	Reserved	OFF

4-bit dip switch (SW2)

SW2	ON	OFF	Default
SW2-1	MODE key disabled	Normal	OFF
SW2-2	The buzzer does not sound when you press the key (normal buzzer when using the remote controller)	Normal	OFF
SW2-3	Reserved	Reserved	OFF
SW2-4	Reserved	Reserved	OFF

Functions	What to do
Function selection	In ON mode, press  for 5 seconds after turning on the backlight.
Forced cooling	Press  for 5 seconds in cooling mode at OFF state: the buzzer will sound for 2 times and the screen will show the LL symbol.
Forced heating	Press  for 5 seconds in heating mode at OFF state: the buzzer will sound for 2 times and the screen will show the HH symbol.
Child lock	When the device is on (ON), press  simultaneously for 5 seconds to set or cancel the child lock function. When the device is turned off (OFF), press  simultaneously for 5 seconds to set or cancel the child lock after the backlight is turned on. The buzzer will sound for 1 time.
Temperature compensation	With the device off (OFF), press  for 5 seconds after the backlight is turned on, adjust using  and confirm by pressing  .
Error query (error codes)	After the backlight is turned on, press  for 5 s to access the error query condition. Under error query condition, press  for 5 seconds to clear the current error code and history.
Setting wired controller mode	When the device is off (OFF), press  for 10 seconds to access the settings. Then press  to adjust and confirm with  .
Switching from degrees Celsius to degrees Fahrenheit	Adjust the set temperature to 30 degrees Celsius (if the ECO temperature limit is set, adjust to maximum temperature.). Then press  for 15 seconds to switch to degrees Fahrenheit.
Switching from degrees Celsius to degree Fahrenheit	Adjust the set temperature to the lowest value in degrees Fahrenheit (if the ECO temperature limit is set, adjust to minimum temperature). Then press  for 15 seconds to switch to degrees Celsius.

CONTROLLER WIRING

Electrical connections

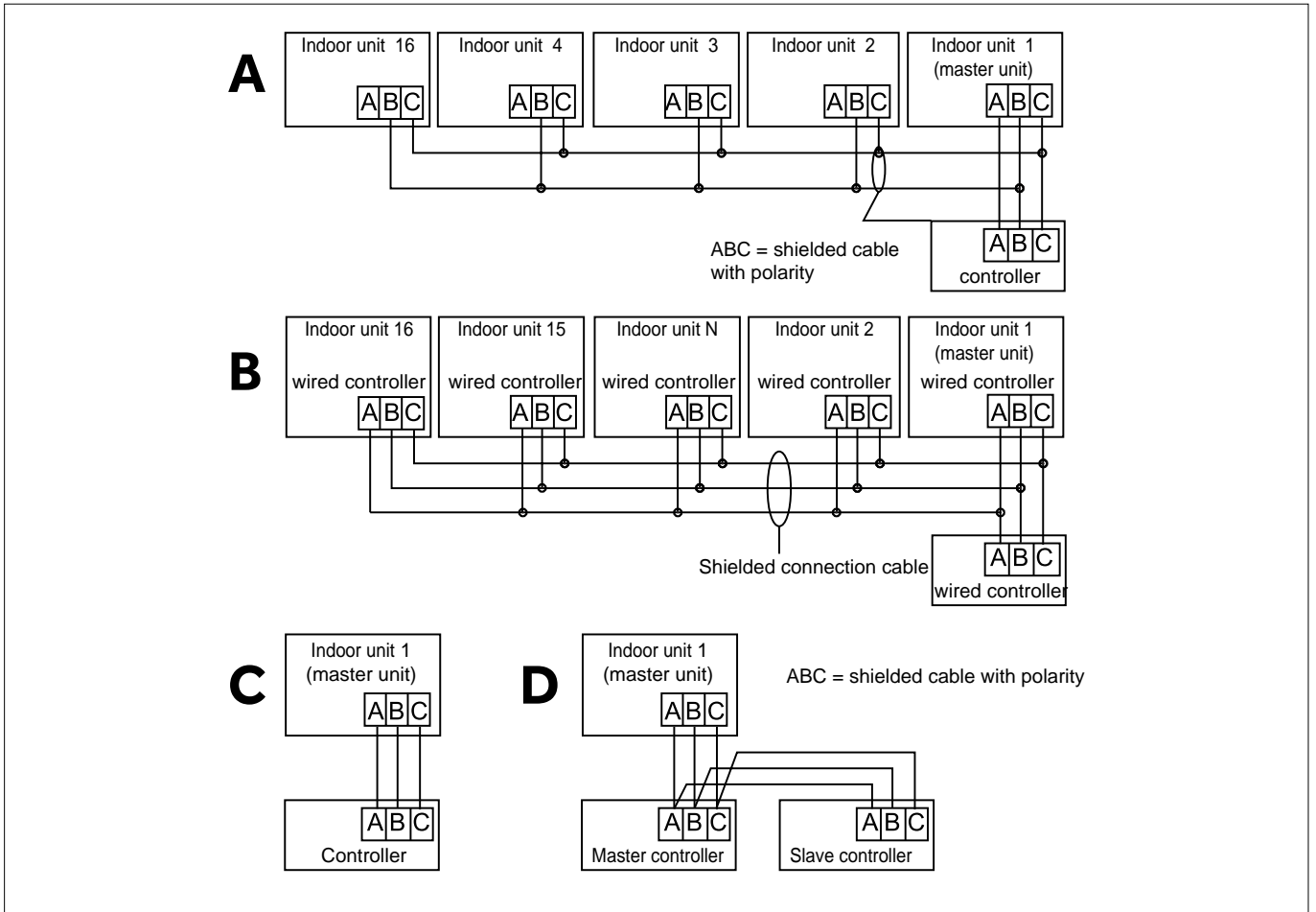

There are four methods to connect the wired controller with the indoor units.

- A. **(For boards with outdoor transformer)** a single wired controller can control up to 16 indoor units. The wired controller will be connected via a three-conductor polarized shielded cable (A-B-C) to the first indoor unit that will be addressed as "Master" (refer to the indoor unit board settings), while the other indoor units will be connected by a cable with only two conductors (B-C).
- B. **(For boards with transformer on board)** same conditions as case A, but all indoor units will be connected by the same cable with three conductors (A-B-C).
- C. A wired controller controls a single indoor unit via a polarized three-conductor shielded cable (A-B-C)
- D. Two wired controllers control a single indoor unit. The first wired controller, set as "Master" (SW1-OFF) is connected with the indoor unit and the second wired controller set as "Slave" (SW1-ON) via a polarized three-conductor shielded cable (A-B-C).

A-B-C communication cable specifications	
Cable length (m)	Cable section
<100	3x0.5mm ² + SCH*
≥100 and <200	3x0.5mm ² + SCH*
≥200 and <300	3x0.75 mm ² + SCH*
≥300 and <400	3x1.5 mm ² + SCH*
≥400 and <500	3x2 mm ² + SCH*

*connect only one end of the screen to ground.

INSTRUCTIONS FOR WIRED CONTROLLER CABLING

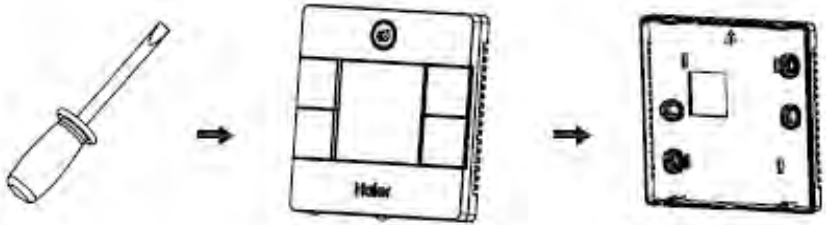
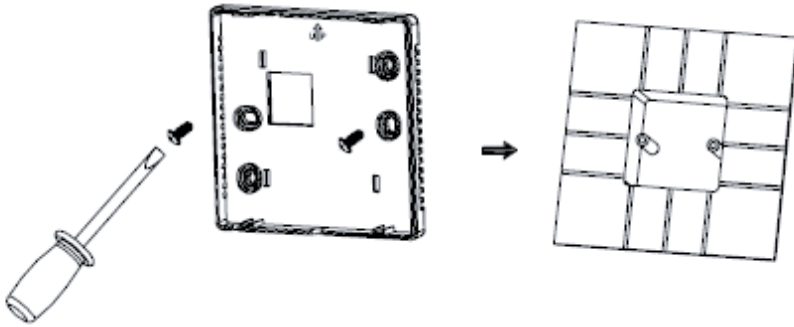
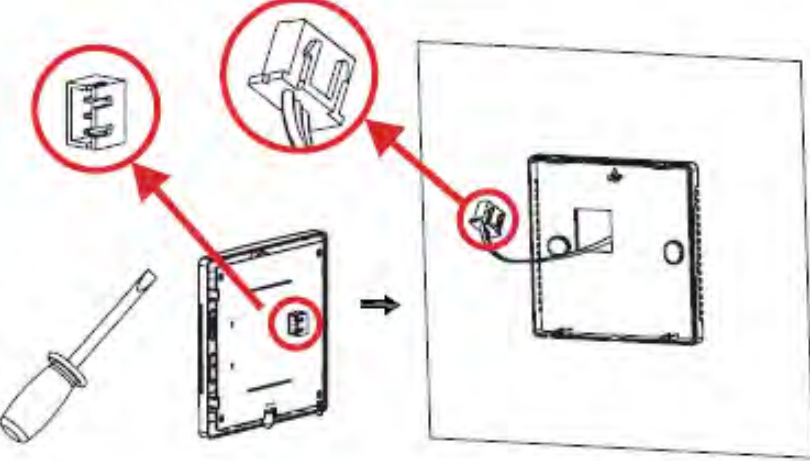
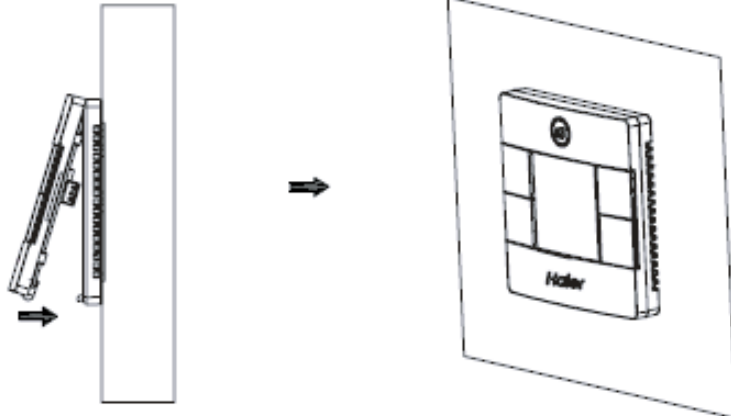
Installation schemes	
<p>1. Use a screwdriver to detach the front panel from the back panel.</p>	 <p>The diagram illustrates the first step of the installation process. It shows a screwdriver being used to pry the front panel away from the back panel. The front panel is shown being lifted off the back panel, revealing the internal components.</p>
<p>2. Fix the back panel.</p>	 <p>The diagram illustrates the second step of the installation process. It shows the back panel being fixed to the wall using a screwdriver. The back panel is shown being pushed against the wall, and a screw is being inserted into the back panel to secure it.</p>
<p>3. Insert the cable connector into the terminal block.</p>	 <p>The diagram illustrates the third step of the installation process. It shows the cable connector being inserted into the terminal block. The cable connector is shown being pushed into the terminal block, and the terminal block is shown being secured to the back panel.</p>
<p>4. Finally, re-assemble the front panel and the back as illustrated here.</p>	 <p>The diagram illustrates the final step of the installation process. It shows the front panel being re-assembled onto the back panel. The front panel is shown being pushed onto the back panel, and the back panel is shown being secured to the wall.</p>

DISPLAY INTERFACE



OPERATION

Meaning SW1 Selection Dip Switches

The selection switches are located on the electronic board in the rear of the controller.















DIP switch		Position	Description	Default settings
SW3	SW3-1	ON	Wired controller SLAVE	OFF
		OFF	Wired controller MASTER	
	SW3-2	ON	Displays ambient temperature	OFF
		OFF	Does not display ambient temperature	
	SW3-3	ON	Ambient temperature reading from wire control	OFF
		OFF	Ambient temperature reading from indoor unit	
	SW3-4	ON	Data storage not active	OFF
		OFF	Data storage active	
	SW3-5	ON	Protocol 1.0	OFF
		OFF	Auto-adaptation protocol	
	SW3-6	ON	Backlight always on	OFF
		OFF	Backlight for 15 s	
	SW3-7	ON	Reserved	OFF
		OFF	Reserved	
	SW3-8	ON	Eco function selectable	OFF
		OFF	Eco function not selectable	

DIP switch		Position	Description	Default settings
SW3	SW2-1	ON	Limited mode function	OFF
		OFF	Normal mode function	
	SW2-2	ON	Buzzer not active when keys are pressed	OFF
		OFF	Buzzer active when keys are pressed	
	SW2-3	ON	Reserved	OFF
		OFF	Reserved	
	SW2-4	ON	Reserved	OFF
		OFF	Reserved	

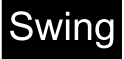
Initialization

After turning on the wired controller or resetting it, all display icons will light up, the software version will be displayed, and 88.8 will be displayed until initialization is completed. If the wired controller fails to communicate normally with the indoor unit board after power on, initialization will be reset within 4 minutes, after which a communication error will be generated between the wired controller and indoor unit.

List of special functions (for other functions see the user manual)

Displaying Error Codes
<p>In case of malfunction, the  icon will be displayed on the main screen.</p> <p>Displaying Error Codes:</p> <p>Hold down  and  for 5 seconds. The current error code will be displayed in the temperature display area (center), and the number of the indoor unit in error will be displayed in the lower right corner. (Indoor unit no. displayed in hexadecimal from 0 to F).</p> <p>Press  to change the indoor unit number. (Note: "--" indicates no malfunction)</p> <p>To view any historical errors, press  and .</p> <p>Up to 4 historical errors are stored, the illumination of semicircle dots indicates the historical error number displayed.</p>
Temperature compensation
<p>This function is used for calibration and compensation of the displayed ambient temperature.</p> <p>With the wired controller Off, press and hold  and  for 5 seconds to set ambient temperature compensation after the backlight is on.</p> <p>The parameter will appear in the temperature display area, and the default value is 0.</p> <p>It can be changed via the  and  keys in a range from -4°C to +4°C (-8 to +8°F).</p> <p>After completing the adjustment, press  to confirm. If no key is pressed within 10 seconds, the parameter setting interface will be automatically closed and the parameter settings will be invalid.</p>
Edit Static Pressure (ESP)
<p>When the wired controller is off, press and hold  and  for 5 seconds to adjust the level of static pressure (ESP) after the backlight is on.</p> <p>The value of the ESP parameter will appear in the temperature display area and it can be adjusted by pressing the  or  keys; the number of the indoor unit concerned is displayed in the lower right corner</p> <p>(in hexadecimal 0 to F). Press  to change the indoor unit and press  to confirm the parameters.</p>
Forced Cooling / Heating Mode
<p>When the wired controller is Off, in Cooling mode, press and hold  for 5 seconds to turn it on and activate the forced cooling function. "LL" will flash in the temperature display area. In this mode, the system works in Cooling mode, fixed setpoint of 16°C and high-speed ventilation. In this mode, all keys are inhibited except the ON/OFF key.</p> <p>Press  to exit the forced mode and turn off the air conditioner.</p> <p>When the wired controller is Off, in Heating mode, press and hold  for 5 seconds to turn it on and activate the forced heating function. "HH" will flash in the temperature display area. In this mode, the system works in Cooling mode, fixed setpoint of 30°C and high-speed ventilation. In this mode, all keys are inhibited except the ON/OFF key.</p> <p>Press  to exit the forced mode and turn off the air conditioner.</p>

CONTROLLER WIRING

Electrical connections

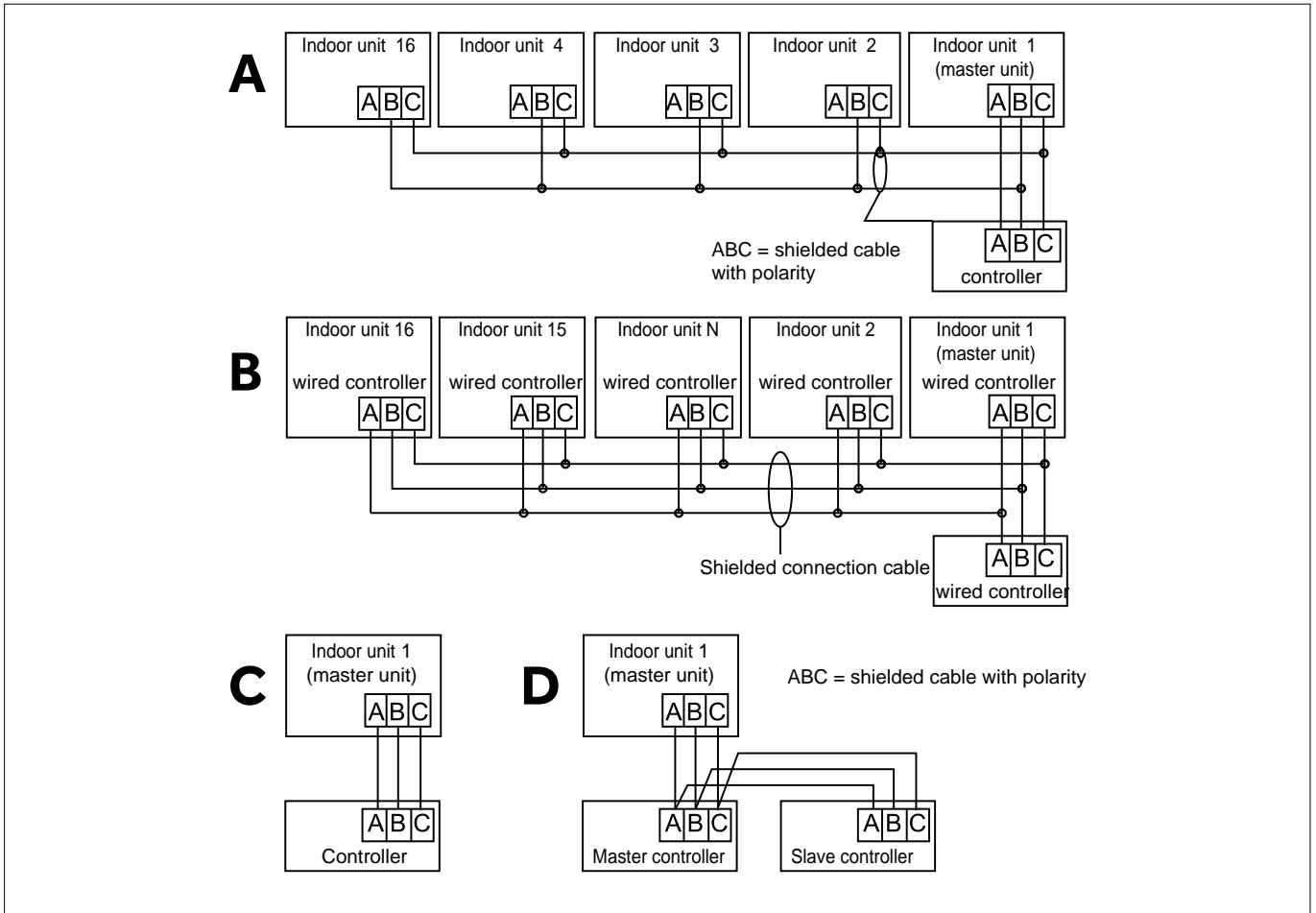

There are four methods to connect the wired controller with the indoor units.

- A. **(For boards with outdoor transformer)** a single wired controller can control up to 16 indoor units. The wired controller will be connected via a three-conductor polarized shielded cable (A-B-C) to the first indoor unit that will be addressed as "Master" (refer to the indoor unit board settings), while the other indoor units will be connected by a cable with only two conductors (B-C).
- B. **(For boards with transformer on board)** same conditions as case A, but all indoor units will be connected by the same cable with three conductors (A-B-C).
- C. A wired controller controls a single indoor unit via a polarized three-conductor shielded cable (A-B-C)
- D. Two wired controllers control a single indoor unit. The first wired controller, set as "Master" (SW1-OFF) is connected with the indoor unit and the second wired controller set as "Slave" (SW1-ON) via a polarized three-conductor shielded cable (A-B-C)

A-B-C communication cable specifications	
Cable length (m)	Cable section
<100	3x0.5mm ² + SCH*
≥100 and <200	3x0.5mm ² + SCH*
≥200 and <300	3x0.75 mm ² + SCH*
≥300 and <400	3x1.5 mm ² + SCH*
≥400 and <500	3x2 mm ² + SCH*

*connect only one end of the screen to ground.

CLASSIFICATION OF INDOOR UNIT TEMPERATURE PROBES

Model	Function	Part Code	Characteristic
AB25S2SA1FA(H)	Indoor Ambient Temperature Sensor	001A3900159	R25=23KΩ±3% B25/50=4200K±3%
AB35S2SA1FA(H)			
AB50S2SA1FA(H)			
AB71S2SA1FA(H)			
AD25S2SS1FA(H)			
AD35S2SS1FA(H)	Indoor Coil Temperature Sensor	001A3900006	R25=10KΩ±3% B25/50=3700K±3%
AD50S2SS1FA(H)			
AD71S2SS1FA(H)			
AD35S2SM3FA(H)			
AD50S2SM3FA(H)	Indoor Ambient Temperature Sensor	001A3900159	R25=23KΩ±3% B25/50=4200K±3%
AD71S2SM3FA(H)			
AD105S2SM3FA(H)			
AD125S2SM8FA(H)	Indoor Coil Temp. Sensor	0010401922	R25=10KΩ±3% B25/50=3700K±3%
AD140S2SM8FA(H)			
AD160S2SM3FA(H)			
AF25S2SD1FA(D)	Indoor Ambient Temperature Sensor	001A3900159	R25=23KΩ±3% B25/50=4200K±3%
AF35S2SD1FA(D)			
AF42S2SD1FA(D)	Indoor Coil Temp. Sensor	001A3900006	R25=10KΩ±3% B25/50=3700K±3%
AF50S2SD1FA(D)			
AC25S2SG1FA(H)	Indoor Ambient Temperature Sensor	001A3900159	R25=23KΩ±3% B25/50=4200K±3%
AC50S2SG1FA(H)			
AC105S2SH1FA(H)			
AC140S2SK1FA(H)			
AC35S2SG1FA(H)	Indoor Coil Temperature Sensor	001A3900006	R25=10KΩ±3% B25/50=3700K±3%
AC71S2SG1FA(H)			
AC125S2SK1FA(H)			
AC160S2SK1FA(H)			
AP105S2SK1FA(H)	Indoor Ambient Temperature Sensor	0010451323A	R25=23KΩ±3% B25/50=4200K±3%
AP140S2SK1FA(H)	Indoor Coil Temperature Sensor	0010401922	R25=10KΩ±3% B25/50=3700K±3%
AP160S2SK1FA(H)			
ADH125H1ERG	Ambient temp. sensor	0010451323	R25=23KΩ±3% B25/50=4200K±3%
ADH140H1ERG			
ADH160H1ERG	Indoor coil temp. sensor	001A3900006	R25=10KΩ±3% B25/50=3700K±3%
AN100S2ST1FA	Water Inlet Temperature Sensor	0150409003	R25=10kΩ±3% B25/50=3700K±3%
	Water Outlet Temperature Sensor	0150409003	R25=10kΩ±3% B25/50=3700K±3%
AN200S2ST1FA	Water Inlet Temperature Sensor	0150409003	R25=10kΩ±3% B25/50=3700K±3%
	Water Outlet Temperature Sensor	0150409003	R25=10kΩ±3% B25/50=3700K±3%

CLASSIFICATION OF OUTDOOR UNIT TEMPERATURE PROBES

Model	Function	Part Code	Characteristic
1U105S2SS2FA 1U140S2SP2FA	Defrost temp.sensor	0010450194	R25=10KΩ±3% B25/50=3700K±3%
	Ambient temp.sensor	0010450192	R25=10KΩ±3% B25/50=3700K±3%
	Discharging temp.sensor	0010451303	R80=50KΩ±3% B25/50=4450K±3%
	Coil temp.sensor	0010451329	R25=10KΩ±3% B25/50=3700K±3%
	Suction temperature sensor	0010451307	R25=10KΩ±3% B25/50=3700K±3%
1U125S2SN2FA 1U125S2SN2FB 1U140S2SN1FA 1U140S2SN1FB	Ambient temp.sensor	0010450192	R25=10KΩ±3% B25/50=3700K±3%
	Coil temp.sensor	0010451328	R25=10KΩ±3% B25/50=3700K±3%
	Suction temperature sensor	0010450949	R25=10KΩ±3% B25/50=3700K±3%
	Defrost temp.sensor	0010451307	R25=10KΩ±3% B25/50=3700K±3%
	Discharging temp.sensor	0010451303	R80=50KΩ±3% B25/50=4450K±3%
1U140S2SP2FB 1U160S2SP1FB	Defrost temp.sensor	0010451307	R25=10KΩ±3% B25/50=3700K±3%
	Ambient temp.sensor	0010450192	R25=10KΩ±3% B25/50=3700K±3%
	Discharging temp.sensor	0010451303	R80=50KΩ±3% B25/50=4450K±3%
	Coil temp.sensor	0010451328	R25=10KΩ±3% B25/50=3700K±3%
	Suction temperature sensor	0010450949	R25=10KΩ±3% B25/50=3700K±3%
3U55S2SR5FA	Gas Liquid Sensor	0150402454	R25=10KΩ±3% B25/50=3700K±3%
	Defrost Temperature Sensor	0150402521	R25=10KΩ±3% B25/50=3700K±3%
4U75S2SR5FA 4U85S2SR5FA	Gas Liquid Sensor	0150402453A	R25=10KΩ±3% B25/50=3700K±3%
	Defrost Temperature Sensor	0150402521	R25=10KΩ±3% B25/50=3700K±3%
5U90S2SS5FA 5U125S2SN1FA	Gas liquid sensor	0150402453	R25=10KΩ±3% B25/50=3700K±3%
	Defrosting temp sensor	0150402521	R25=10KΩ±3% B25/50=3700K±3%

OHMIC VALUES DEPENDING ON TEMPERATURE

R25=10K±3% B25/50=3700K±3%			
T (°C)	Rnom (KΩ)	T (°C)	Rnom (KΩ)
-20	90.79	31	7.83
-19	85.72	32	7.52
-18	80.96	33	7.23
-17	76.51	34	6.95
-16	72.33	35	6.68
-15	68.41	36	5.43
-14	64.73	37	5.6
-13	61.27	38	5.59
-12	58.02	39	5.73
-11	54.97	40	5.52
-10	52.1	41	5.32
-9	49.4	42	5.12
-8	46.86	43	4.93
-7	44.46	44	4.9
-6	42.21	45	4.58
-5	40.08	46	4.42
-4	38.08	47	4.26
-3	36.19	48	4.11
-2	34.41	49	3.97
-1	32.73	50	3.83
0	31.14	51	3.7
1	29.64	52	3.57
2	28.22	53	3.45
3	26.4	54	3.33
4	25.61	55	3.22
5	24.41	56	3.11
6	23.27	57	3.11
7	22.2	58	2.9
8	21.18	59	2.81
9	20.21	60	2.72
10	19.3	61	2.63
11	18.43	62	2.54
12	17.61	63	2.49
13	16.83	64	2.38
14	16.09	65	2.3
15	15.38	66	2.23
16	14.71	67	2.16
17	14.08	68	2.09
18	13.48	69	2.03
19	12.9	70	1.96
20	12.36	71	1.9
21	11.84	72	1.85
22	11.34	73	1.79
23	10.87	74	1.73
24	10.43	75	1.68
25	10	76	1.63
26	9.59	77	1.58
27	9.21	78	1.54
28	8.84	79	1.49
29	8.48	80	1.45
30	8.15		

OHMIC VALUES DEPENDING ON TEMPERATURE

R25=23KΩ±3% B25/50=4200K±3%							
T (°C)	Rnom (KΩ)	T (°C)	Rnom (KΩ)	T (°C)	Rnom (KΩ)	T (°C)	Rnom (KΩ)
-10	149.07	27	20.94	64	4.52	101	1.32
-9	140.35	28	20.00	65	4.36	102	1.28
-8	132.20	29	19.10	66	4.21	103	1.25
-7	124.59	30	18.24	67	4.05	104	1.21
-6	117.46	31	17.43	68	3.91	105	1.18
-5	110.79	32	16.66	69	3.77	106	1.14
-4	104.54	33	15.93	70	3.64	107	1.11
-3	98.69	34	15.24	71	3.51	108	1.08
-2	93.20	35	14.58	72	3.39	109	1.05
-1	88.06	36	13.95	73	3.28	110	1.02
0	83.23	37	13.35	74	3.16	111	0.99
1	78.70	38	12.79	75	3.06	112	0.96
2	74.45	39	12.25	76	2.95	113	0.93
3	70.46	40	11.73	77	2.85	114	0.91
4	66.70	41	11.24	78	2.76	115	0.88
5	63.18	42	10.78	79	2.66	116	0.86
6	59.86	43	10.33	80	2.58	117	0.84
7	56.74	44	9.91	81	2.49	118	0.81
8	53.80	45	9.51	82	2.41	119	0.79
9	51.03	46	9.12	83	2.33	120	0.77
10	48.42	47	8.76	84	2.26	121	0.75
11	45.97	48	8.41	85	2.18	122	0.73
12	43.65	49	8.07	86	2.11	123	0.71
13	41.46	50	7.75	87	2.05	124	0.69
14	39.40	51	7.45	88	1.98	125	0.67
15	37.46	52	7.16	89	1.92	126	0.66
16	35.62	53	6.88	90	1.86	127	0.64
17	33.89	54	6.62	91	1.80	128	0.62
18	32.25	55	6.36	92	1.74	129	0.61
19	30.70	56	6.12	93	1.69	130	0.59
20	29.23	57	5.89	94	1.64	131	0.58
21	27.84	58	5.67	95	1.59	132	0.56
22	26.53	59	5.46	96	1.54	133	0.55
23	25.29	60	5.25	97	1.49	134	0.53
24	24.11	61	5.06	98	1.45		
25	23.00	62	4.87	99	1.41		
26	21.94	63	4.70	100	1.36		

Haier
HVAC Solutions

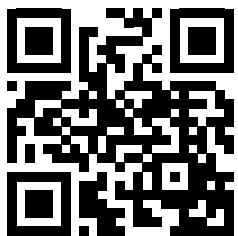

Haier HVAC
haierhvac.eu

Copyright © 2024 Haier. All rights reserved.

