

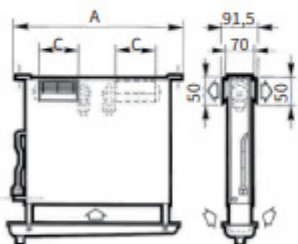

* (See note)

250 - 430 W

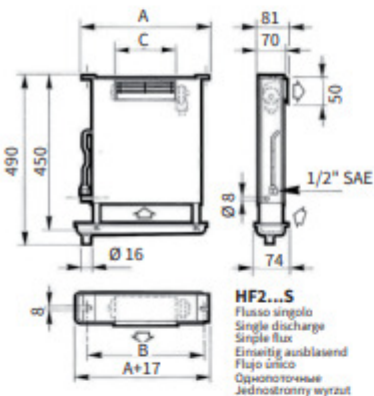

4.3 mm Passo alette / Fin spacing

TC = 10 - 0 °C

Modello	Type	HF2	57S	72S	106S	58D	109D	
Potenza (R404)	(+)TC 2,5 °C (ΔT1 10 K)	W	250	370	420	260	430	
Capacity	TC 0 °C (ΔT1 8 K)	W	190	280	310	190	320	
Portata d'aria	Air quantity	m ³ /h	60	90	90	65	100	
Freccia d'aria	Air throw	m	3,5	3,5	3,5	2x3,5	2x3,5	
Elettroventilatori	Fans	n°	1	1	1	2	2	
Assorbimento motori	Motor power consumption	1-230 V	W	15	16	16	26	30
		50 Hz	A	0,15	0,16	0,16	0,26	0,30
Sbrinamento	Defrost	E 230 V	W	330	330	450	330	450
Dimensioni	Dimensions	A	mm	370	370	490	370	490
		B	mm	340	340	460	340	460
		C	mm	120	180	180	2 x 60	2 x 120
Attacchi entrata	Inlet connections	Ø mm	8	8	8	8	8	
Volume circuito	Circuit volume	dm ³	0,30	0,30	0,42	0,30	0,42	
Superficie esterna	External surface	m ²	2,0	2,0	2,9	2,0	2,9	
Superficie interna	Internal surface	m ²	0,17	0,17	0,25	0,17	0,25	
Peso	Weight	kg	3,3	3,4	4,2	3,8	4,8	