

Data sheet

Hot gas bypass regulator

Type KVC



KVC is a hot gas bypass regulator applied for the adaption of the compressor capacity to the actual evaporator load.

Placed in a bypass between high and low pressure sides of the refrigeration system, KVC imposes a lower limit on the compressor suction pressure by supplying the low pressure side with replacement capacity in the form of hot gas / cool gas from the high pressure side.

Features

- Accurate, adjustable pressure regulation
- Wide capacity and operating ranges
- Pulsation damping design
- Stainless steel bellows
- Compact angle design for easy installation
- "Hermetic" brazed construction
- Available with flare and ODF solder connections
- Compliant with ATEX hazard zone 2

Data sheet | Hot gas bypass regulator, type KVC

Approvals

UL LISTED, file SA7200
EAC

Technical data

Refrigerants	R22, R1270, R1290, R134a, R404A, R407C, R507A, R600, R600a
Regulating range	0.2 – 6.0 bar Factory setting = 2 bar
Maximum working pressure	PS/MWP = 28 bar
Maximum test pressure	Pe = 31 bar
Medium temperature range	-45 – 130 °C
Maximum P-band	2.0 bar
K, value at maximum P-band ¹⁾	KVC 12 = 0.68 m ³ / h
	KVC 15 = 1.25 m ³ / h
	KVC 20 = 1.85 m ³ / h

¹⁾ The K, value is the flow of water in [m³ / h] at a pressure drop across valve of 1 bar, ρ = 1000 kg / m³

This product is approved for R600, R600a, R1270, and R1290 by ignition source assessment in accordance with standard EN13463-1.

For complete list of approved refrigerants, visit www.products.danfoss.com and search for individual code numbers, where refrigerants are listed as part of technical data.

Ordering

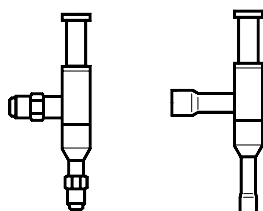

Type	Rated capacity ¹⁾ [kW]				Flare connection ²⁾		Code no.	Solder connection		Code no.
	R22	R134a	R404A/ R507	R407C	[in.]	[mm]		[in.]	[mm]	
KVC 12	7.6	4.8	6.9	8.4	½	12	034L0141	½	–	034L0143
	7.6	4.8	6.9	8.4	–	–	–	–	12	034L0146
KVC 15	14.9	9.4	13.6	16.4	¾	16	034L0142	¾	16	034L0147
KVC 22	19.1	12.0	17.4	21.0	–	–	–	¾	22	034L0144

¹⁾ Rated capacity is the regulator capacity at:
evaporating temperature t_e = -10 °C
condensing temperature t_c = 25 °C
offset = 0.7 bar

²⁾ KVC is supplied without flare nut. Separate flare nuts can be ordered:
½ in. / 12 mm, code no. 011L1103
¾ in. / 16 mm, code no. 011L1167

The connection dimensions chosen must not be too small, since gas velocities in excess of 40 m/s at the inlet of the regulator can give flow noise.

If the discharge tube temperature becomes too high in relation to the compressor specification, the installation of an injection valve in a bypass between liquid line and compressor suction line is recommended.

Replacement capacity

R22

Type	Offset Δp [bar]	Q ¹⁾ [kW] suction gas temperature t _s after pressure / temperature reduction [°C]						
		-45	-40	-30	-20	-10	0	10
KVC 12	0.10	–	2.3	2.4	2.5	2.5	2.6	2.6
	0.15	–	3.5	3.6	3.7	3.8	3.9	4.0
	0.20	–	4.5	4.7	4.8	4.9	5.0	5.1
	0.30	–	5.9	6.1	6.3	6.4	6.5	6.7
	0.50	–	6.6	6.8	7.1	7.2	7.3	7.5
	0.70	–	7.0	7.2	7.4	7.6	7.8	7.9
	1.00	–	7.6	7.9	8.1	8.3	8.5	8.6
	1.20	–	8.2	8.5	8.7	8.9	9.1	9.3
KVC 15	0.10	–	3.5	3.6	3.7	3.8	3.9	4.0
	0.15	–	4.5	4.7	4.8	4.9	5.0	5.1
	0.20	–	5.9	6.1	6.3	6.4	6.5	6.7
	0.30	–	8.2	8.5	8.7	8.9	9.1	9.3
	0.50	–	11.7	12.1	12.4	12.7	13.0	13.2
	0.70	–	13.7	14.2	14.6	14.9	15.2	15.5
	1.00	–	15.6	16.2	16.7	17.0	17.3	17.7
	1.20	–	16.8	17.4	17.9	18.3	18.7	19.0
KVC 22	0.10	–	3.7	3.8	3.9	4.0	4.1	4.2
	0.15	–	5.1	5.2	5.4	5.5	5.6	5.7
	0.20	–	6.8	7.0	7.3	7.4	7.5	7.7
	0.30	–	8.4	8.6	8.9	9.1	9.3	9.5
	0.50	–	14.1	14.5	15.0	15.3	15.6	15.9
	0.70	–	17.6	18.1	18.7	19.1	19.5	19.9
	1.00	–	21.4	22.4	23.1	23.6	24.1	24.5
	1.20	–	23.8	24.6	25.4	25.9	26.4	26.9

¹⁾ The capacities are based on condensing temperature t_c = 25 °C

Correction factors

When selecting, the required regulator capacity is to be multiplied by a correction factor dependent on the condensing temperature.

The corrected capacity can then be found from the table. Correction factors for condensing temperature can be found in section “selection”.

$$\text{System capacity} \times \text{correction factor} = \text{table capacity}$$

Replacement capacity
(continued)

R134a

Type	Offset Δp	Q ¹⁾ [kW] suction gas temperature t _s after pressure / temperature reduction [°C]						
	[bar]	-45	-40	-30	-20	-10	0	10
KVC 12	0.10	–	–	1.4	1.4	1.5	1.7	1.7
	0.15	–	–	2.1	2.3	2.4	2.5	2.6
	0.20	–	–	2.9	3.0	3.1	3.2	3.4
	0.30	–	–	3.7	3.9	4.1	4.3	4.5
	0.50	–	–	4.2	4.3	4.5	4.8	4.9
	0.70	–	–	4.4	4.5	4.8	5.0	5.2
	1.00	–	–	4.8	5.0	5.2	5.5	5.8
	1.20	–	–	5.1	5.4	5.6	5.8	6.1
KVC 15	0.10	–	–	2.1	2.3	2.4	2.5	2.6
	0.15	–	–	2.9	3.0	3.1	3.2	3.4
	0.20	–	–	3.7	3.9	4.1	4.3	4.5
	0.30	–	–	5.1	5.4	5.6	5.8	6.1
	0.50	–	–	7.4	7.7	8.0	8.4	8.7
	0.70	–	–	8.7	9.1	9.4	9.9	10.2
	1.00	–	–	9.9	10.2	10.7	11.3	11.7
	1.20	–	–	10.6	11.1	11.6	12.2	12.6
KVC 22	0.10	–	–	2.3	2.4	2.5	2.6	2.8
	0.15	–	–	3.2	3.3	3.5	3.6	3.7
	0.20	–	–	4.3	4.4	4.6	4.9	5.1
	0.30	–	–	5.2	5.5	5.7	6.0	6.3
	0.50	–	–	8.9	9.3	9.7	10.1	10.5
	0.70	–	–	11.0	11.6	12.0	12.6	13.1
	1.00	–	–	13.7	14.3	14.9	15.6	16.3
	1.20	–	–	15.0	15.7	16.3	17.2	17.8

¹⁾ The capacities are based on
condensing temperature t_c = 25 °C

Correction factors

When selecting, the required regulator capacity is to be multiplied by a correction factor dependent on the condensing temperature.

The corrected capacity can then be found from the table. Correction factors for condensing temperature can be found in section “selection”.

$$\text{System capacity} \times \text{correction factor} = \text{table capacity}$$

Replacement capacity
(continued)

R404A/R507

Type	Offset Δp	Q ¹⁾ [kW] suction gas temperature t _s after pressure / temperature reduction [°C]						
	[bar]	-45	-40	-30	-20	-10	0	10
KVC 12	0.10	–	1.9	2.0	2.1	2.2	2.3	2.4
	0.15	–	3.0	3.1	3.3	3.4	3.5	3.6
	0.20	–	3.9	4.1	4.2	4.5	4.7	4.7
	0.30	–	5.1	5.4	5.6	5.8	6.0	6.1
	0.50	–	5.7	6.0	6.4	6.6	6.8	7.0
	0.70	–	6.0	6.4	6.6	6.9	7.2	7.3
	1.00	–	6.6	6.9	7.2	7.5	7.8	8.0
	1.20	–	7.0	7.4	7.7	8.0	8.4	8.5
KVC 15	0.10	–	3.0	3.1	3.3	3.4	3.5	3.6
	0.15	–	3.9	4.1	4.2	4.5	4.7	4.7
	0.20	–	5.1	5.4	5.6	5.8	6.0	6.1
	0.30	–	7.0	7.4	7.7	8.0	8.4	8.5
	0.50	–	10.1	10.6	11.1	11.6	12.0	12.3
	0.70	–	11.8	12.5	13.0	13.6	14.1	14.4
	1.00	–	13.5	14.2	14.8	15.5	16.1	16.4
	1.20	–	14.5	15.3	16.0	16.6	17.3	17.7
KVC 22	0.10	–	3.2	3.3	3.5	3.6	3.7	3.8
	0.15	–	4.3	4.6	4.8	5.0	5.2	5.3
	0.20	–	5.8	6.1	6.4	6.7	7.0	7.1
	0.30	–	8.2	8.6	8.9	9.3	9.8	9.9
	0.50	–	12.1	12.8	13.4	13.9	14.4	14.7
	0.70	–	15.2	16.0	16.6	17.4	18.1	18.4
	1.00	–	18.8	19.8	20.7	21.5	22.4	22.8
	1.20	–	20.5	21.6	22.6	23.5	24.5	25.0

¹⁾ The capacities are based on
condensing temperature t_c = 25 °C

Correction factors

When selecting, the required regulator capacity is to be multiplied by a correction factor dependent on the condensing temperature.

The corrected capacity can then be found from the table. Correction factors for condensing temperature can be found in section “selection”.

$$\text{System capacity} \times \text{correction factor} = \text{table capacity}$$

Replacement capacity
(continued)

R407C

Type	Offset Δp [bar]	Q ¹⁾ [kW] suction gas temperature t _s after pressure / temperature reduction [°C]						
		-45	-40	-30	-20	-10	0	10
KVC 12	0.10	–	2.4	2.6	2.7	2.8	2.9	3.0
	0.15	–	3.7	3.9	4.0	4.2	4.3	4.6
	0.20	–	4.8	5.0	5.2	5.4	5.6	5.8
	0.30	–	6.3	6.5	6.9	7.0	7.2	7.6
	0.50	–	7.0	7.3	7.7	7.9	8.1	8.6
	0.70	–	7.4	7.7	8.1	8.4	8.7	9.0
	1.00	–	8.1	8.5	8.8	9.1	9.4	9.8
	1.20	–	8.7	9.1	9.5	9.8	10.1	10.6
KVC 15	0.10	–	3.7	3.9	4.0	4.2	4.3	4.6
	0.15	–	4.8	5.0	5.2	5.4	5.6	5.8
	0.20	–	6.3	6.5	6.9	7.0	7.2	7.6
	0.30	–	8.7	9.1	9.5	9.8	10.1	10.6
	0.50	–	12.4	12.9	13.5	14.0	14.4	15.0
	0.70	–	14.5	15.2	15.9	16.4	16.9	17.7
	1.00	–	16.5	17.3	18.2	18.7	19.2	20.2
	1.20	–	17.8	18.6	19.5	20.1	20.8	21.7
KVC 22	0.10	–	3.9	4.1	4.3	4.4	4.6	4.8
	0.15	–	5.4	5.6	5.9	6.1	6.2	6.5
	0.20	–	7.2	7.5	8.0	8.1	8.3	8.8
	0.30	–	8.9	9.2	9.7	10.0	10.3	10.8
	0.50	–	14.9	15.5	16.4	16.8	17.3	18.1
	0.70	–	18.7	19.4	20.4	21.0	21.6	22.7
	1.00	–	22.7	24.0	25.2	26.0	26.8	27.9
	1.20	–	25.2	26.3	27.7	28.5	29.3	30.7

¹⁾ The capacities are based on
condensing temperature t_c = 25 °C

Correction factors

When selecting, the required regulator capacity is to be multiplied by a correction factor dependent on the condensing temperature.

The corrected capacity can then be found from the table. Correction factors for condensing temperature can be found in section “selection”.

$$\text{System capacity} \times \text{correction factor} = \text{table capacity}$$

Sizing

For optimum performance, it is important to select a KVC valve according to system conditions and application.

The following data must be used when sizing a KVC valve:

- Refrigerant
- Minimum suction temperature: t_s in [°C] / [bar]
- Compressor load in [kW]
- Evaporator load in [kW]
- Condensing temperature: t_i in [°C]
- Connection type: flare or solder
- Connection size in [in.]

Valve selection

Example

When selecting the appropriate valve it may be necessary to convert the actual evaporator capacity using a correction factor. This is required when your system conditions are different than the table conditions. The selection is also dependant on the acceptable pressure drop across the valve.

The following example illustrates how this is done:

- Refrigerant: R134a
- Minimum suction temperature: $t_s = -12\text{ °C} \sim 0.9\text{ bar}$
- Compressor capacity at $-12\text{ °C} = 15.4\text{ kW}$
- Evaporator load at $-12\text{ °C} = 10.0\text{ kW}$
- Condensing temperature: $t_i = 35\text{ °C}$
- Connection type: solder
- Connection size: $\frac{5}{8}$ in.

Step 1

Determine the correction factor for condensing temperature t_i .

From the correction factors table (see below) a condensing temperature of 35 °C , R134a corresponds to a factor of 1.10.

Correction factors for condensing temperature t_i

t_i [°C]	10	15	20	25	30	35	40	45	50
R134a	0.88	0.92	0.96	1.0	1.05	1.10	1.16	1.23	1.31
R22	0.90	0.93	0.96	1.0	1.05	1.10	1.13	1.18	1.24
R404A/R507	0.84	0.89	0.94	1.0	1.07	1.16	1.26	1.40	1.57
R407C	0.88	0.91	0.95	1.0	1.05	1.11	1.18	1.26	1.35

Step 2

The required replacement capacity is defined as the (compressor capacity – the evaporator load) divided by the correction factor = $(15.4-10.0) / 1.10 = 4.9\text{ kW}$

Step 3

Now select the appropriate capacity table and choose the column for minimum suction temperature $t_s = -20\text{ °C}$. Using the corrected replacement capacity, select a valve that provides an equivalent or greater capacity than required.

KVC 15 delivers 5.4 kW at an offset of 0.3 bar. Based on the required connection size of $\frac{5}{8}$ in. ODF, the KVC 15 is the proper selection for this example.

Step 4

KVC 15, $\frac{5}{8}$ in. solder connection: code no. **034L0147**, see ordering list.

Design / Function

KVC

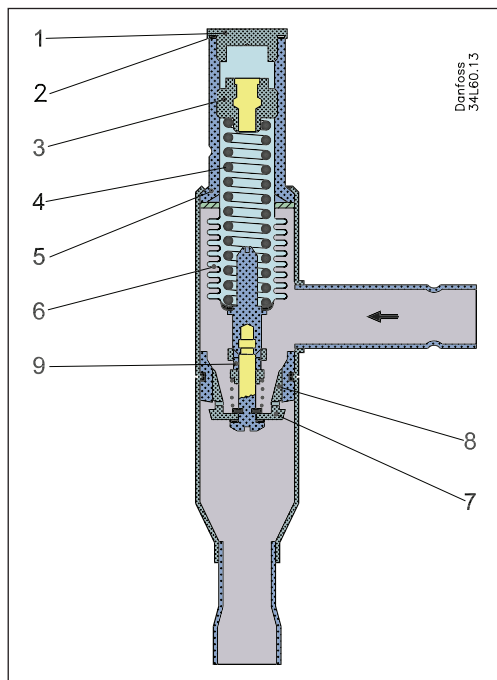

- 1. Protective cap
- 2. Gasket
- 3. Setting screw
- 4. Main spring
- 5. Valve body
- 6. Equalization bellows
- 7. Valve plate
- 8. Valve seat
- 9. Damping device

The hot gas bypass regulator KVC opens at a fall in pressure on the outlet side, i.e. when the pressure in the evaporator is beyond the set value.

KVC regulates only in dependence on the outlet pressure. Pressure variations on the inlet side of the regulator do not affect the degree of opening since KVC is equipped with an equalization bellows (6). This bellows has an effective area corresponding to that of the valve seat.

The hot gas bypass regulator is also equipped with an effective damping device (9) against pulsations which can normally arise in a refrigeration plant.

The damping device helps to ensure long life for the regulator without impairing regulation accuracy.

P-band and Offset

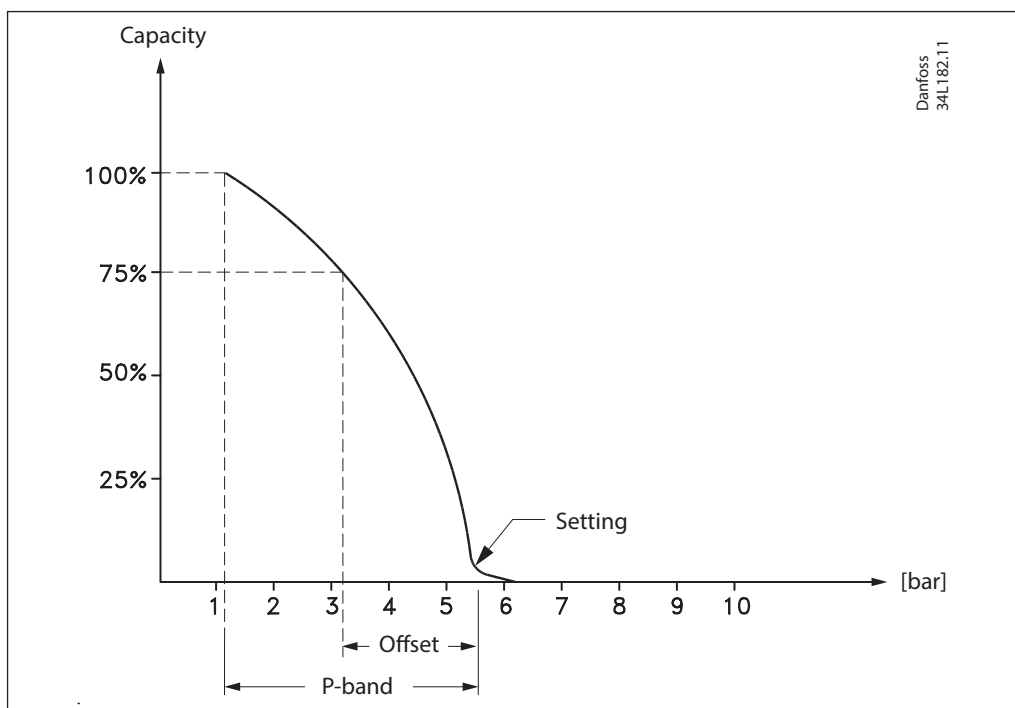

Proportional band

The proportional band or P-band is defined as the amount of pressure required to move the valve plate from closed to full open position.

Example:

If the valve is set to open at 4 bar and the valve p-band is 2, the valve will give maximum capacity when the discharge pressure reaches 2 bar.

Offset

The offset is defined as the permissible pressure variation in suction line pressure (temperature). It is calculated as the difference between the required working pressure and the minimum allowable pressure. The offset is always a part of the P-band.

Example with R404A:

A suction temperature ahead of the compressor of 5 °C ~ 6 bar is required, and the temperature must not drop below 0 °C ~ 5 bar. The offset will then be 1 bar.

Dimensions and weights

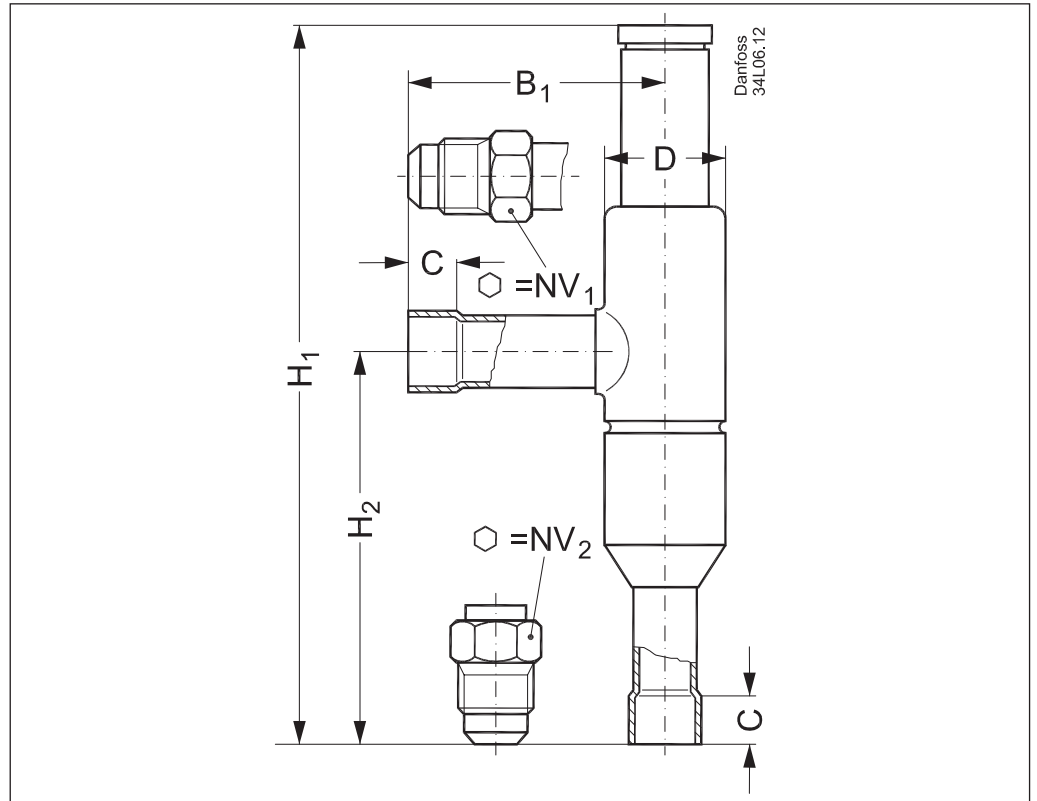

Type	Connection				NV ₁ [mm]	NV ₂ [mm]	H ₁ [mm]	H ₂ [mm]	B ₁ [mm]	C solder [mm]	øD [mm]	Net weight [Kg]
	Flare		Solder ODF									
	[in.]	[mm]	[in.]	[mm]								
KVC 12	½	12	½	12	19	24	179	99	64	10	30	0.4
KVC 15	¾	16	¾	16	24	24	179	99	64	12	30	0.4
KVC 22	-	-	¾	22	-	-	179	99	64	17	30	0.4

Danfoss can accept no responsibility for possible errors in catalogues, brochures and other printed material. Danfoss reserves the right to alter its products without notice. This also applies to products already on order provided that such alterations can be made without subsequential changes being necessary in specifications already agreed. All trademarks in this material are property of the respective companies. Danfoss and the Danfoss logotype are trademarks of Danfoss A/S. All rights reserved.