



Model: NEK2125U
Code: 861CA51

embraco POWER IN.
CHANGE ON

Type:	On-off
Voltage [V] / Frequency [Hz] / Phases	220-240 V 50 Hz 1 ~
Refrigerant:	R-290
Application:	LBP

Motor type:	
Starting torque:	HST
HP:	1/3
Displacement:	7.28 cm ³

OPERATING CONDITION : ARI LBP

Evaporation Temp.	-23.3 °C	Return Temp.	4.4 °C	Superheating	27.7 K
Condensing Temp.	48.9 °C	Liquid Temp.	48.9 °C	Subcooling	0.0 K

Cooling capacity	Power consumption	Mass flow rate	Efficiency
272.05 W	232.40 W	3.78 kg/h	1.17 W/W

APPLICATION

Evaporating temperature range:	-40 to -10 °C	Cooling type:	Fan Cooling
Permanent operating temperature (peak) :	55 (60) °C	Air Flow	--
Expansion device:	Capillary tube or Expansion valve	Maximum motor temperature:	130 °C

SEE OUR CAPILLARY TUBE SIZING SUGGESTION FOR PRELIMINARY TESTS

Number of capillaries	Length [m]	Internal diameter [mm]	Application
1.00	4.40	0.91	LBP

ELECTRICAL DATA

Start winding resistance at 25°C (77°F):	28.9 Ω +/- 8%	Run winding resistance at 25°C (77°F):	6.8 Ω +/- 8%
FLA - full load amperage L/MBP [A] 50 Hz / 60 Hz:	- / -	LRA (A) 50 Hz / 60 Hz:	- / -
		FLA - full load amperage HBP [A] 50 Hz / 60 Hz:	- / -

MECHANICAL DATA

Bore:	26.5 mm	Stroke:	6.6 mm
		Displacement:	7.28 cm ³

OTHER INFORMATION

Weight:	10.4 kg	Oil charge:	350 ml
Lubricant type:	Polyolester ISO22	Nitrogen charge:	No

EXTERNAL SETTINGS

-	Shape	Material	Diameter [mm]
Suction connector	Slanted 42°	Copper	8.10
Discharge connector	Straight	Copper	6.10
Process connector	Slanted 42°	Copper	6.10

Base plate:	European Standard	Tray holder:	No
-------------	-------------------	--------------	----

PERFORMANCES AT STANDARD CHECK-POINTS

Checkpoint	Cooling capacity	Power consumption	Gas flow rate	Cooling Efficiency	Heating capacity +/-	Heating Efficiency
	+/-5%	+/-5%	+/-5%	+/- 7%	5% *	+/- 7%
	W	W	kg/h	W/W	W	W/W
ARI LBP	272.05	232.40	3.78	1.17	387.70	1.67
ASHRAE LBP 32	335.35	247.01	3.41	1.36	458.70	1.86
CECOMAF LBP	255.75	241.70	3.21	1.06	376.60	1.56
EN12900 LBP**	211.56	183.35	2.28	1.15	302.08	1.65
EN12900 MBP**	537.70	284.43	6.17	1.89	683.89	2.40

* Calculations performed considering isentropic compression and a housing loss of 10%. This is an estimated heat amount discarded in the discharge pipe and the condenser combined.

CONDENSING TEMP. 35 °C

(SUBCOOLING : 0 K, RETURN TEMP.: 32 °C)

Evaporating temperature °C	Cooling capacity	Power consumption	Gas flow rate	Cooling Efficiency	Heating capacity +/-	Heating Efficiency
	+/-5%	+/-5%	+/-5%	+/- 7%	5% *	+/- 7%
	W	W	kg/h	W/W	W	W/W
-40.00	183.97	157.23	1.90	1.17	263.33	1.67
-35.00	219.93	176.28	2.27	1.25	305.25	1.73
-30.00	266.71	194.20	2.76	1.37	359.36	1.85
-25.00	328.78	212.31	3.42	1.55	430.51	2.03
-20.00	408.93	230.40	4.26	1.77	520.93	2.26
-15.00	509.24	247.46	5.33	2.06	631.75	2.55
-10.00	631.55	262.14	6.64	2.41	763.73	2.91

CONDENSING TEMP. 45 °C

(SUBCOOLING : 0 K, RETURN TEMP.: 32 °C)

Evaporating temperature °C	Cooling capacity	Power consumption	Gas flow rate	Cooling Efficiency	Heating capacity +/-	Heating Efficiency
	+/-5%	+/-5%	+/-5%	+/- 7%	5% *	+/- 7%
	W	W	kg/h	W/W	W	W/W
-40.00	166.68	166.57	1.87	1.00	253.29	1.52
-35.00	202.83	190.18	2.29	1.07	298.41	1.57
-30.00	240.99	208.94	2.72	1.15	343.65	1.64
-25.00	289.56	227.01	3.28	1.28	400.66	1.76
-20.00	353.33	245.90	4.02	1.44	474.89	1.93
-15.00	435.32	265.41	4.97	1.64	568.89	2.14
-10.00	537.70	284.43	6.17	1.89	683.89	2.40

CONDENSING TEMP. 55 °C

(SUBCOOLING : 0 K, RETURN TEMP.: 32 °C)

Evaporating temperature °C	Cooling capacity	Power consumption	Gas flow rate	Cooling Efficiency	Heating capacity +/-	Heating Efficiency
	+/-5%	+/-5%	+/-5%	+/- 7%	5% *	+/- 7%
	W	W	kg/h	W/W	W	W/W
-40.00	125.10	160.05	1.55	0.78	203.39	1.27
-35.00	177.87	198.89	2.22	0.89	279.48	1.41
-30.00	216.23	223.04	2.70	0.97	328.73	1.47
-25.00	255.75	241.70	3.21	1.06	376.60	1.56
-20.00	305.05	259.98	3.84	1.17	435.55	1.68
-15.00	369.12	279.65	4.67	1.32	511.52	1.83
-10.00	451.09	300.54	5.74	1.50	607.32	2.02

ECM	REVISION	LO	BY	APP	DATE	
33471	25	ADDED NEW MODEL NEUR214Z	TAB	LF	WG	11.04.2014
33788	26	ADDED NEW MODEL NEUR214U	TAB	LK	WG	07.05.2014
34098	27	ADDED MODELS NEUR21406A, NEUR21556A	TAB	LF	WG	02.06.2014
32548	28	ADDED MODELS NEUR210Z, NEUR212Z, NEUR2148A, NEUR210U, NEUR210U ADDED "NEU" TO THE DESCRIPTION	TAB	MR	LF	22.9.2014
37454	29	ADDED NOTE: CSIR, RSIR, RSCR TO PG.1; ADDED PAGE 2 - CSR CONFIGURATION; MODELS NEUR210Z, NEUR212Z, NEUR2148A, NEUR210U, NEUR210U MOVED FROM PG.1 TO PG.2; CHANGE POSITION OF REFRIGERANT LABEL - PG.3;	E6 TAB	KK	RR	11.03.2015
35759	30	ADDED MODEL NEUR187Z	TAB	WP	WG	10.06.2015
38932	31	ADDED SHELL TYPE R10.32 AND MODEL NEU111Z	TAB	WG	RR	12.01.2016
31531	32	ADDED MODELS NEUR220U, NEUR212U, NEUR2206A; MODEL TABLES MOVED TO SHEET 3; SHEET 3 REMOVED;	TAB	PS	WG	05.10.2016
44703	33	CHANGED DIMENSION KK FROM 201 TO 200 mm AND FROM 211 TO 206 mm;	TAB	KK	WG	05.01.2017

Ø 16^{+0,25} (6 HOLES)

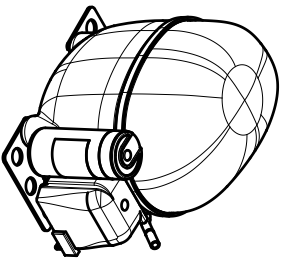
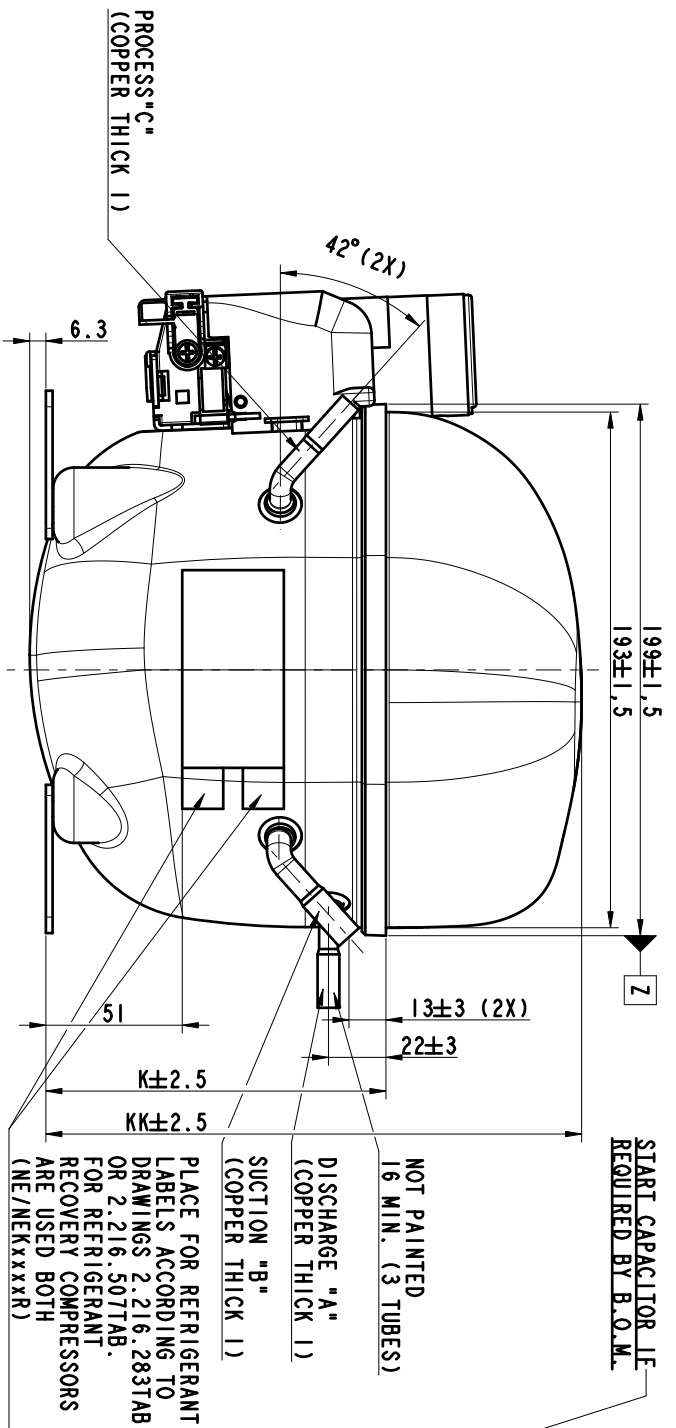
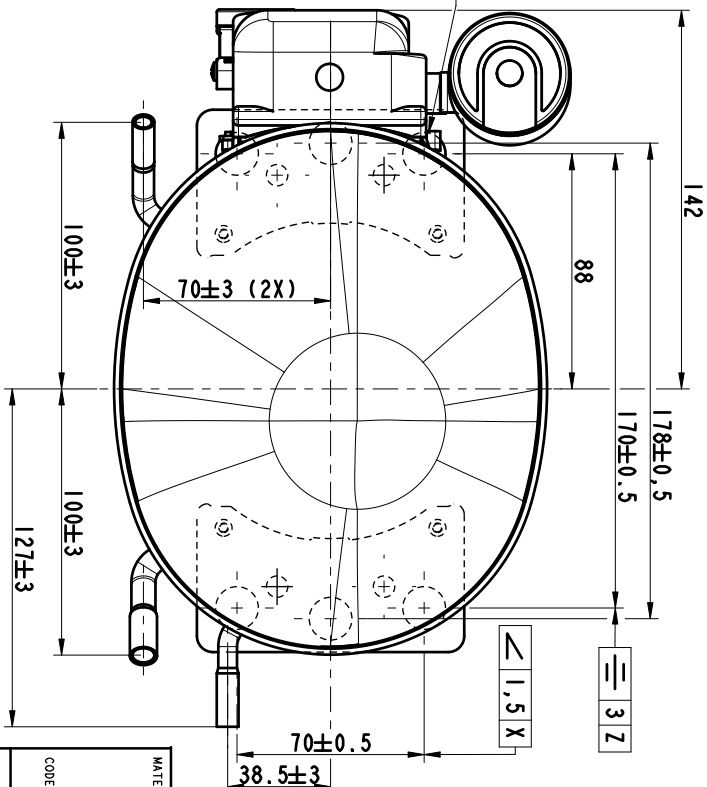

SCALE 1:5

CSIR, RSIR, RSCR

MATERIAL :

CODE :

DRAWN : TONELLA M.

APP. : MARTINO J.

ECM : 503723

06-10-2003

NAME

embraco

SHEET 1/3

EXTERNAL VIEW "NEK", "NBT", "NEU"

VISTA ESTERNA "NEK", "NBT", "NEU"

EXTERNÝ POHĽAD "NEK", "NBT", "NEU"

GEN. TOL. :

ANG. TOL. :

SCALE : 1:2

REPLACE

No. 1.960.853

THIS MATERIAL IS SPECIALLY TREATED AND PROTECTED TO EMBRACO PURPOSE AND ANY USE OR REPRODUCTION WITHOUT AUTHORIZATION OF EMBRACO IS PROHIBITED.

ECM	REVISION	LO	BY	APP	DATE	
33471	25	ADDED NEW MODEL NEUR214Z	TAB	LF	WG	11.04.2014
33788	26	ADDED NEW MODEL NEUR214U	TAB	LK	WG	07.05.2014
34098	27	ADDED MODELS NEUR214G6, NEUR21556	TAB	LF	WG	02.06.2014
32548	28	ADDED MODELS NEUR210Z, NEUR212Z, NEUR2148A, NEUR210U ADDED "NEU" TO THE DESCRIPTION	TAB	MR	LF	22.9.2014
37454	29	ADDED NOTE: CSIR, RSIR, RSCR TO PG.1; ADDED PAGE 2 - CSR CONFIGURATION; MODELS NEUR210U, NEUR212U, NEUR2148A, NEUR21556 MOVED FROM PG.1 TO PG.2; CHANGE POSITION OF REFRIGERANT LABEL - PG.3	E6 TAB	KK	RR	11.03.2015
35759	30	ADDED MODEL NEUR187Z	TAB	MP	WG	10.06.2015
38932	31	ADDED SHELL TYPE R10.32 AND MODEL NEU111Z	TAB	MG	RR	12.01.2016
31531	32	ADDED MODELS NEUR220U, NEUR212U, NEUR2206; MODEL TABLES MOVED TO SHEET 3; SHEET 3 REMOVED;	TAB	PS	WG	05.10.2016
44703	33	CHANGED DIMENSION KK FROM 201 TO 200 mm AND FROM 241 TO 236 mm;	TAB	KK	WG	05.01.2017

Ø 16^{+0,25} (6 HOLES)

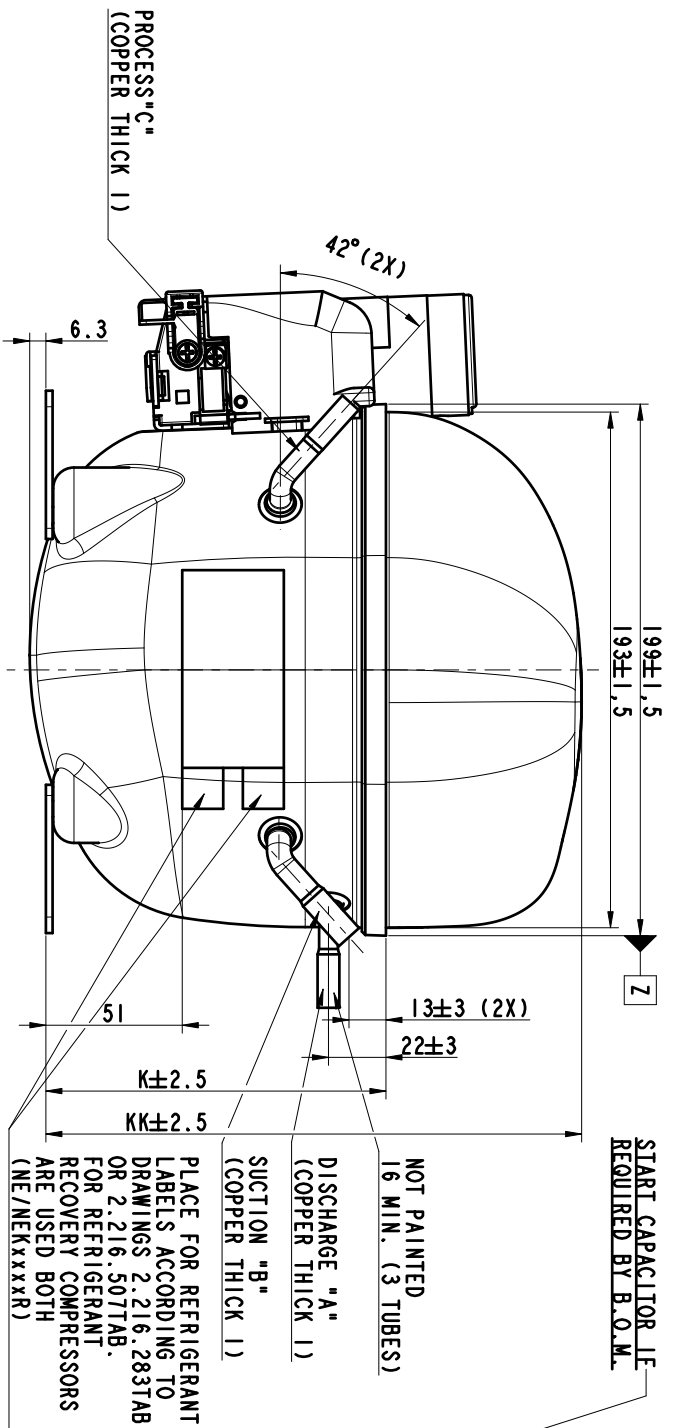
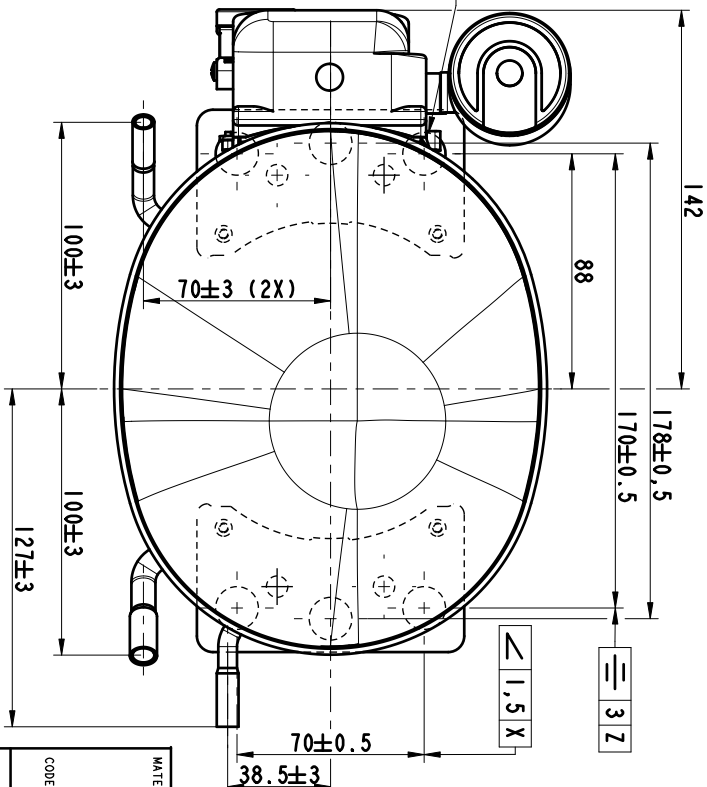

START CAPACITOR LE
REQUIRED BY B.O.M.

NOT PAINTED
16 MIN. (3 TUBES)

DISCHARGE "A"
(COPPER THICK 1)

SUCTION "B"
(COPPER THICK 1)

PLACE FOR REFRIGERANT
LABELS ACCORDING TO
DRAWINGS 2.216.507TAB,
OR 2.216.507TAB.
FOR REFRIGERANT
RECOVERY COMPRESSORS
ARE USED BOTH
(NE/NEKXXXXR)

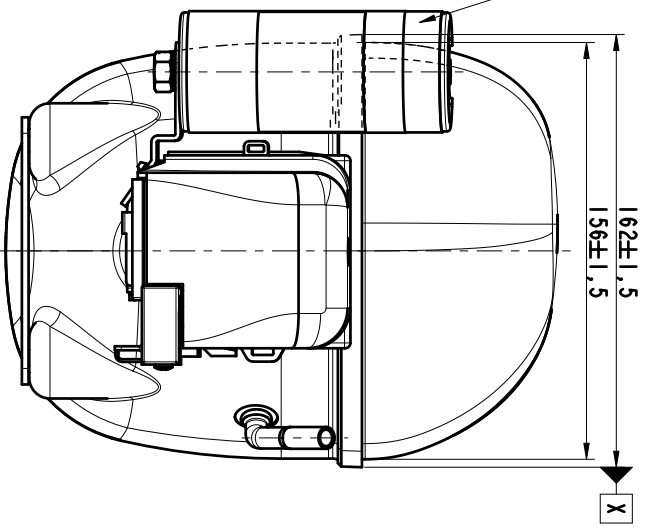

CSIR, RSIR, RSCR

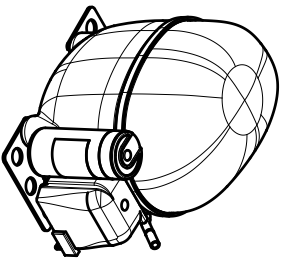

SCALE 1:5

MATERIAL :		DRAWN : TONELLA M.	
CODE :		APP. : MARTINO J.	
DATE :		06-10-2003	
ECM : 503723		THIS MATERIAL IS SUPPLIED AS SUCH AND IS NOT TO BE REFINISHED, VIT-COATED, VITRIFIED OR HARDENED AND ANY OF THE REFINISHING OPERATIONS ARE NOT TO BE PERFORMED WITHOUT WRITTEN PERMISSION.	
embraco SHEET 1/3 NAME EXTERNAL VIEW "NEK", "NBT", "NEU" VISTA ESTERNA "NEK", "NBT", "NEU" EXTERNY POHLAD "NEK", "NBT", "NEU"		GEN. TOL. :	
		ANG. TOL. :	
SCALE :		1:2	
REPLACE			
No.		1.960.853	

ECM	REVISION	LO	BY	APP	DATE	
33471	25	ADDED NEW MODEL NEUR214Z	TAB	LF	WG	11.04.2014
33788	26	ADDED NEW MODEL NEUR214U	TAB	LK	WG	07.05.2014
34098	27	ADDED MODELS NEUR214G6, NEUR21556	TAB	LF	WG	02.06.2014
32548	28	ADDED MODELS NEUR210Z, NEUR212Z, NEUR2148A, NEUR210U ADDED "NEU" TO THE DESCRIPTION	TAB	MR	LF	22.9.2014
37454	29	ADDED NOTE: CSIR, RSIR, RSCR TO PG.1; ADDED PAGE 2 - CSR CONFIGURATION; MODELS NEUR210U, NEUR212U, NEUR2148A, NEUR21556 MOVED FROM PG.1 TO PG.2; CHANGE POSITION OF REFRIGERANT LABEL - PG.3.	E6 TAB KK BA	RR	WG	11.03.2015
35759	30	ADDED MODEL NEUR187Z	TAB	WP	WG	10.06.2015
38932	31	ADDED SHELL TYPE R10.32 AND MODEL NEU111Z	TAB	WG	RR	12.01.2016
31531	32	ADDED MODELS NEUR220U, NEUR212U, NEUR2206; MODEL TABLES MOVED TO SHEET 3; SHEET 3 REMOVED;	TAB	PS	WG	05.10.2016
44703	33	CHANGED DIMENSION KK FROM 201 TO 200 mm AND FROM 241 TO 236 mm.	TAB	KK	WG	05.01.2017

Ø 16^{+0,25} (6 HOLES)

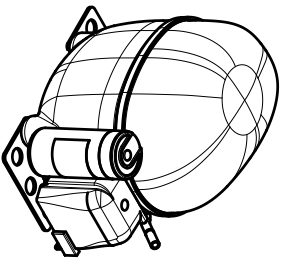
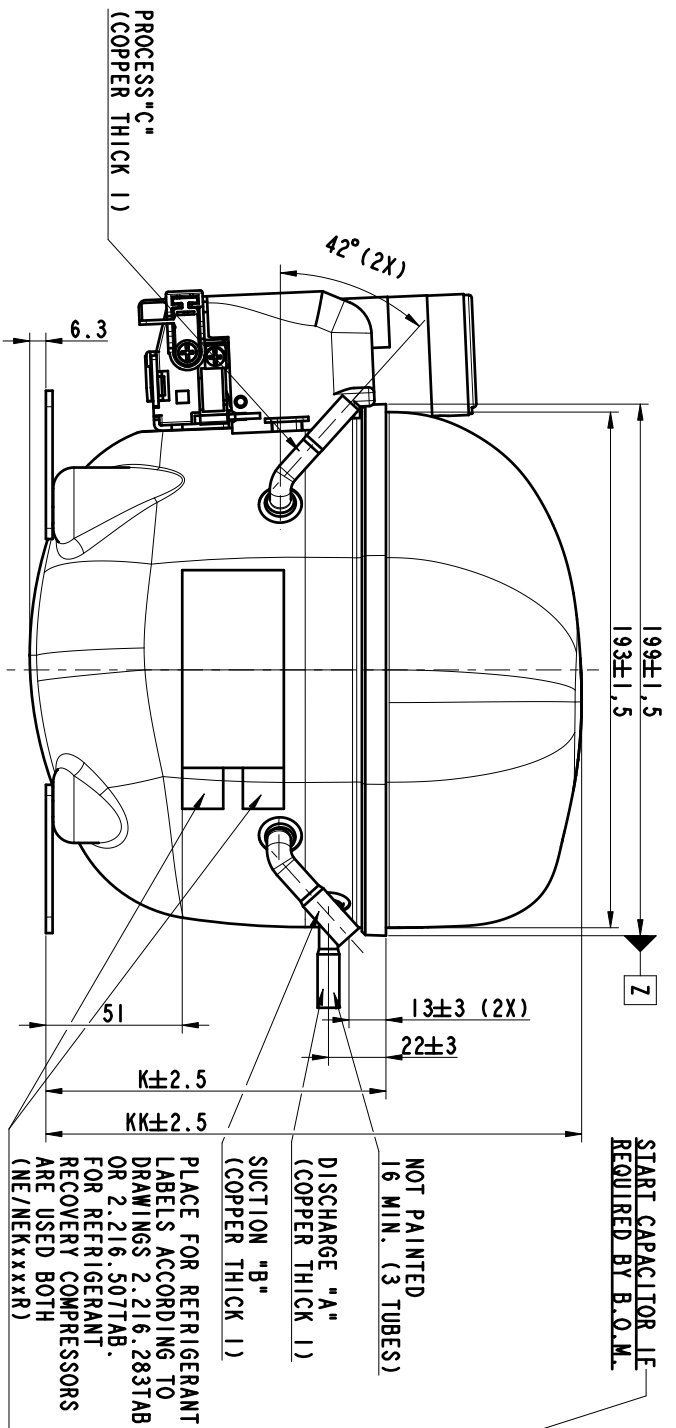
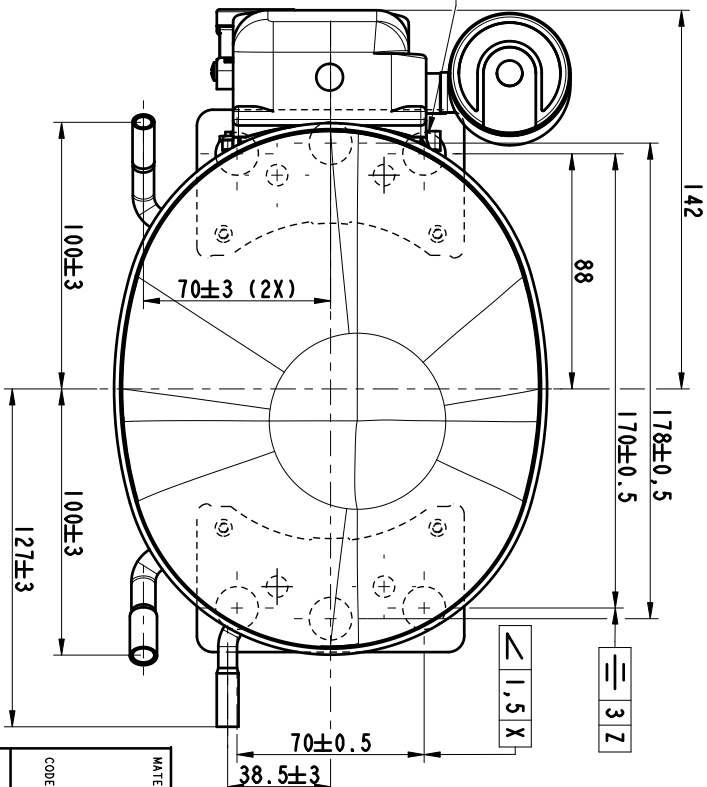

SCALE 1:5

CSIR, RSIR, RSCR

MATERIAL :

CODE :

DRAWN : TONELLA M.

APP. : MARTINO J.

ECM : 503723

06-10-2003

NAME

embraco

SHEET 1/3

EXTERNAL VIEW "NEK", "NBT", "NEU"
VISTA ESTERNA "NEK", "NBT", "NEU"
EXTERNY POHLAD "NEK", "NBT", "NEU"

GEN. TOL. :

ANG. TOL. :

SCALE : 1:2

REPLACE

No. 1.960.853

THIS MATERIAL IS SUPPLIED AS IS AND IS NOT TO BE USED IN ANY APPLICATION WHERE THE USER'S SAFETY OR THE SAFETY OF OTHERS DEPENDS ON THE PROPER USE OF THIS MATERIAL.