



Model: NEU2140GK  
Code: 958JA51

**embraco** POWER IN.  
CHANGE ON

Type:	On-off
Voltage [V] / Frequency [Hz] / Phases	220-240 V 50 Hz 1 ~
Refrigerant:	R-404A
Application:	LBP

Motor type:	CSIR
Starting torque:	HST
HP:	1/2
Displacement:	8.77 cm <sup>3</sup>

### OPERATING CONDITION : ASHRAE LBP 32

Evaporation Temp.	-23.3 °C	Return Temp.	32.2 °C	Superheating	55.5 K
Condensing Temp.	54.4 °C	Liquid Temp.	32.2 °C	Subcooling	22.2 K

<b>Cooling capacity</b>	<b>Power consumption</b>	<b>Mass flow rate</b>	<b>Efficiency</b>
467.88 W	362.37 W	10.87 kg/h	1.29 W/W

### APPLICATION

Evaporating temperature range:	-40 to -10 °C	Cooling type:	Fan Cooling
Permanent operating temperature (peak) :	55 (60) °C	Air Flow	--
Expansion device:	Capillary tube or Expansion valve	Maximum motor temperature:	130 °C

### SEE OUR CAPILLARY TUBE SIZING SUGGESTION FOR PRELIMINARY TESTS

Number of capillaries	Length [m]	Internal diameter [mm]	Application
1.00	3.10	0.91	LBP

### ELECTRICAL DATA

Start winding resistance at 25°C (77°F):	24.26 Ω +/- 8%	Run winding resistance at 25°C (77°F):	7.79 Ω +/- 8%
FLA - full load amperage L/MBP [A] 50 Hz / 60 Hz:	2.63 / -	LRA (A) 50 Hz / 60 Hz:	13.5 / -
		FLA - full load amperage HBP [A] 50 Hz / 60 Hz:	- / -

### MECHANICAL DATA

Bore:	26.5 mm	Stroke:	7.96 mm
		Displacement:	8.77 cm <sup>3</sup>

### OTHER INFORMATION

Weight:	10.6 kg	Oil charge:	350 ml
Lubricant type:	Polyolester ISO22	Nitrogen charge:	No

### EXTERNAL SETTINGS

-	Shape	Material	Diameter [mm]
Suction connector	Slanted 42°	Copper	8.10
Discharge connector	Straight	Copper	6.10
Process connector	Slanted 42°	Copper	6.10

Base plate:	European Standard	Tray holder:	No
-------------	-------------------	--------------	----

## PERFORMANCES AT STANDARD CHECK-POINTS

Checkpoint	Cooling capacity	Power consumption	Gas flow rate	Cooling Efficiency	Heating capacity +/-	Heating Efficiency
	+/-5%	+/-5%	+/-5%	+/- 7%	5% *	+/- 7%
	W	W	kg/h	W/W	W	W/W
ARI LBP	352.69	386.67	12.45	0.91	525.24	1.36
ASHRAE LBP 32	467.88	362.37	10.87	1.29	648.77	1.79
CECOMAF LBP	317.89	345.36	9.90	0.92	489.59	1.42
EN12900 LBP**	260.28	251.39	6.53	1.04	380.30	1.51
EN12900 MBP**	791.33	467.27	21.73	1.69	1,026.12	2.20

\* Calculations performed considering isentropic compression and a housing loss of 10%. This is an estimated heat amount discarded in the discharge pipe and the condenser combined.

## CONDENSING TEMP. 35 °C

(SUBCOOLING : 22.2 K, RETURN TEMP.: 32 °C)

Evaporating temperature °C	Cooling capacity	Power consumption	Gas flow rate	Cooling Efficiency	Heating capacity +/-	Heating Efficiency
	+/-5%	+/-5%	+/-5%	+/- 7%	5% *	+/- 7%
	W	W	kg/h	W/W	W	W/W
-40.00	263.26	217.36	5.09	1.21	362.23	1.67
-35.00	350.19	248.02	6.79	1.41	468.41	1.89
-30.00	457.13	281.45	8.89	1.62	595.10	2.11
-25.00	587.44	316.44	11.47	1.86	745.12	2.35
-20.00	744.23	351.02	14.60	2.12	920.75	2.62
-15.00	930.69	382.65	18.34	2.43	1,124.24	2.94
-10.00	1,150.36	408.35	22.81	2.82	1,358.07	3.33

## CONDENSING TEMP. 45 °C

(SUBCOOLING : 22.2 K, RETURN TEMP.: 32 °C)

Evaporating temperature °C	Cooling capacity	Power consumption	Gas flow rate	Cooling Efficiency	Heating capacity +/-	Heating Efficiency
	+/-5%	+/-5%	+/-5%	+/- 7%	5% *	+/- 7%
	W	W	kg/h	W/W	W	W/W
-40.00	218.00	217.69	4.58	1.00	316.22	1.45
-35.00	296.08	253.29	6.24	1.17	416.86	1.65
-30.00	390.35	292.45	8.26	1.33	534.06	1.83
-25.00	505.22	335.10	10.73	1.51	672.45	2.01
-20.00	644.13	379.97	13.74	1.70	834.96	2.20
-15.00	810.28	424.96	17.38	1.91	1,023.96	2.41
-10.00	1,006.93	467.27	21.73	2.15	1,241.72	2.66

## CONDENSING TEMP. 55 °C

(SUBCOOLING : 22.2 K, RETURN TEMP.: 32 °C)

Evaporating temperature °C	Cooling capacity	Power consumption	Gas flow rate	Cooling Efficiency	Heating capacity +/-	Heating Efficiency
	+/-5%	+/-5%	+/-5%	+/- 7%	5% *	+/- 7%
	W	W	kg/h	W/W	W	W/W
-40.00	166.27	208.45	3.84	0.80	255.94	1.23
-35.00	240.29	251.33	5.57	0.96	358.38	1.43
-30.00	323.94	296.24	7.54	1.09	468.69	1.58
-25.00	423.89	345.36	9.90	1.23	595.59	1.72
-20.00	544.58	398.76	12.79	1.37	743.90	1.87
-15.00	689.52	455.15	16.29	1.51	916.64	2.01
-10.00	861.90	512.29	20.51	1.68	1,116.18	2.18

## ELECTRICAL ACCESSORIES

Kit:	1
Starter device:	CURRENT RELAY
Engineering code:	MTRPH-0025-65
Run capacitor:	--
Starting capacitor:	64-77

Thermal protector: MST38AMK-3259

Institutes approved for this electric kit:



If purchased without electricals consult Embraco to verify the supplier of electricals approved for this compressor

## MECHANICAL ACCESSORIES

Rubber damper: Yes

Metal bushing: Optional

ECM	REVISION	LO	BY	APP	DATE	
33471	25	ADDED NEW MODEL NEUR214Z	TAB	LF	WG	11.04.2014
33788	26	ADDED NEW MODEL NEUR214U	TAB	LK	WG	07.05.2014
34098	27	ADDED MODELS NEUR21406A, NEUR21556A	TAB	LF	WG	02.06.2014
32548	28	ADDED MODELS NEUR210Z, NEUR212Z, NEUR2148A, NEUR210U, NEUR210U ADDED "NEU" TO THE DESCRIPTION	TAB	MR	LF	22.9.2014
37454	29	ADDED NOTE: CSIR, RSIR, RSCR TO PG.1; ADDED PAGE 2 - CSR CONFIGURATION; MODELS NEUR210Z, NEUR212Z, NEUR2148A, NEUR210U, NEUR210U MOVED FROM PG.1 TO PG.2; CHANGE POSITION OF REFRIGERANT LABEL - PG.3;	E6 TAB	KK	RR	11.03.2015
35759	30	ADDED MODEL NEUR187Z	TAB	MP	WG	10.06.2015
38932	31	ADDED SHELL TYPE R10.32 AND MODEL NEU111ZT	TAB	MG	RR	12.01.2016
31531	32	ADDED MODELS NEUR220U, NEUR212U, NEUR2206C; MODEL TABLES MOVED TO SHEET 3; SHEET 3 REMOVED;	TAB	PS	WG	05.10.2016
44703	33	CHANGED DIMENSION KK FROM 201 TO 200 mm AND FROM 241 TO 236 mm;	TAB	KK	WG	05.01.2017

Ø 16<sup>+0,25</sup> (6 HOLES)

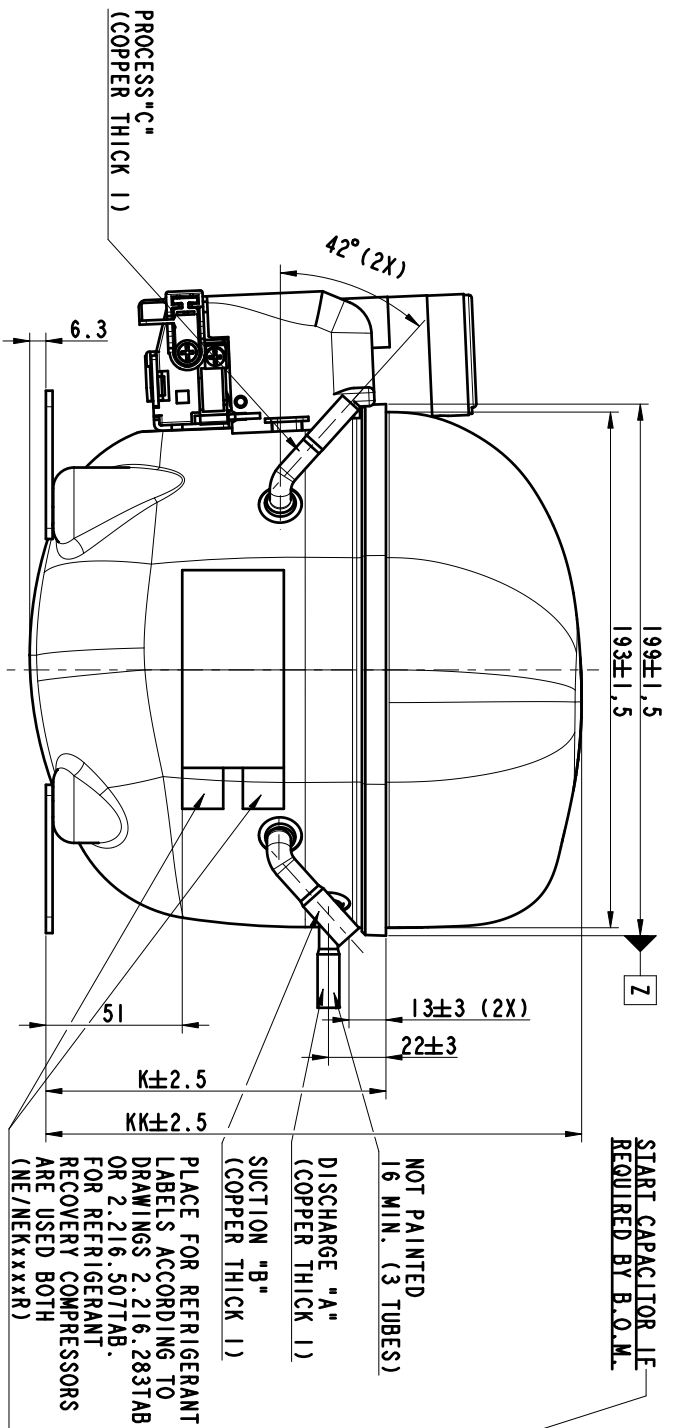
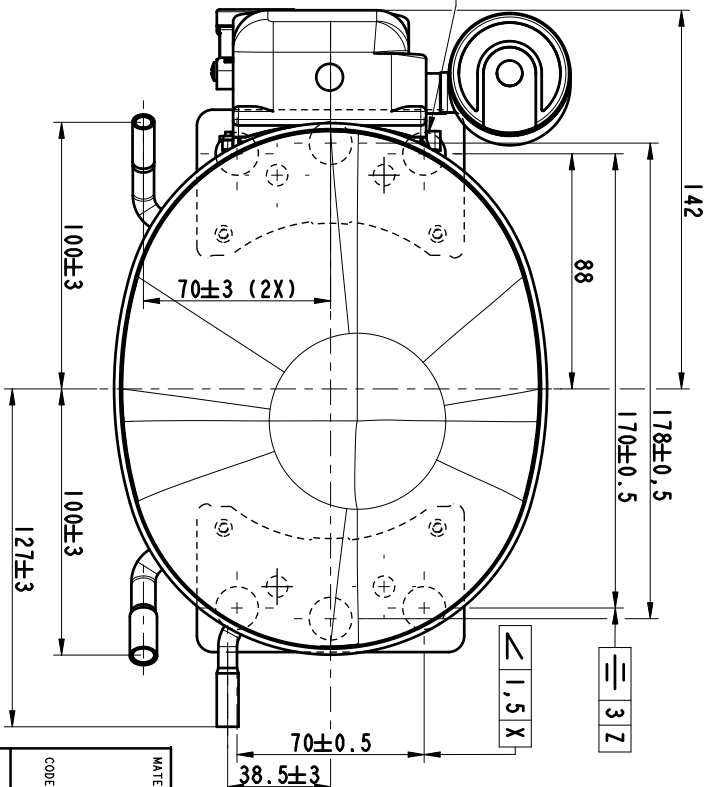

START CAPACITOR LE  
REQUIRED BY B.O.M.

NOT PAINTED  
16 MIN. (3 TUBES)

DISCHARGE "A"  
(COPPER THICK 1)

SUCTION "B"  
(COPPER THICK 1)

PLACE FOR REFRIGERANT  
LABELS ACCORDING TO  
DRAWINGS 2.216.507TAB,  
OR 2.216.507TAB,  
FOR REFRIGERANT  
RECOVERY COMPRESSORS  
ARE USED BOTH  
(NE/NEKxxxxR)

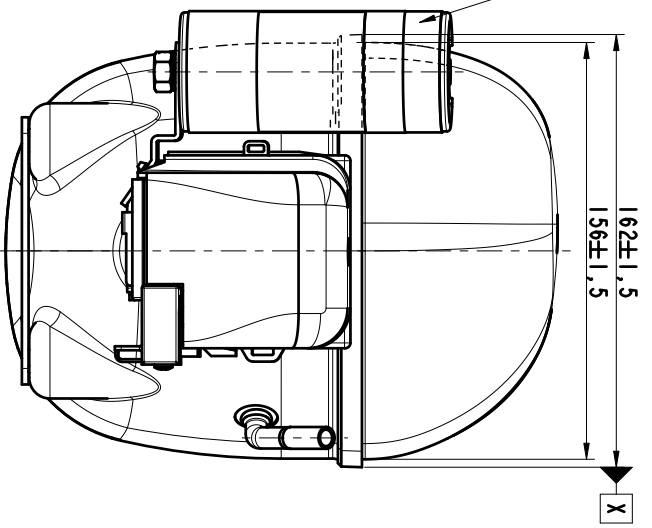

CSIR, RSIR, RSCR

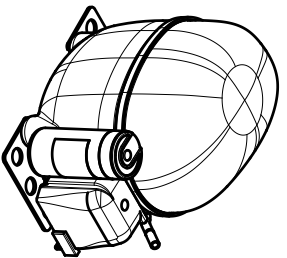

SCALE 1:5

MATERIAL :

CODE :

DRAWN : TONELLA M.

APP. : MARTINO J.

ECM : 503723

06-10-2003

NAME

**embraco**

SHEET 1/3

EXTERNAL VIEW "NEK", "NBT", "NEU"  
VISTA ESTERNA "NEK", "NBT", "NEU"  
EXTERNY POHLAD "NEK", "NBT", "NEU"

GEN. TOL. :

ANG. TOL. :

SCALE : 1:2

REPLACE

No. 1.960.853

THIS MATERIAL IS SUPPLIED AS IS AND IS NOT TO BE USED IN ANY APPLICATION WHERE THE USER'S SAFETY OR THE SAFETY OF OTHERS DEPENDS ON THE PROPER USE OF THE PRODUCT. THE USER SHALL BE RESPONSIBLE FOR THE PROPER USE OF THE PRODUCT.

ECM	REVISION	LO	BY	APP	DATE	
33471	25	ADDED NEW MODEL NEUR214Z	TAB	LF	WG	11.04.2014
33788	26	ADDED NEW MODEL NEUR214U	TAB	LK	WG	07.05.2014
34098	27	ADDED MODELS NEUR21406A, NEUR21556A	TAB	LF	WG	02.06.2014
32548	28	ADDED MODELS NEUR210Z, NEUR212Z, NEUR2148A, NEUR210U ADDED "NEU" TO THE DESCRIPTION	TAB	MR	LF	22.9.2014
37454	29	ADDED NOTE: CSIR, RSIR, RSCR TO PG.1; ADDED PAGE 2 - CSR CONFIGURATION; MODELS NEUR210U, NEUR212Z, NEUR2148A, NEUR210U NEUR210U, NEUR212Z, NEUR2148A MOVED FROM PG.1 TO PG.2; CHANGE POSITION OF REFRIGERANT LABEL - PG.3;	E6 TAB KK BA	RR	WG	11.03.2015
35759	30	ADDED MODEL NEUR187Z	TAB	WP	WG	10.06.2015
38932	31	ADDED SHELL TYPE R10.3Z AND MODEL NEU111ZT	TAB	WG	RR	12.01.2016
31531	32	ADDED MODELS NEUR220U, NEUR212U, NEUR2206; MODEL TABLES MOVED TO SHEET 3; SHEET 3 REMOVED;	TAB	PS	WG	05.10.2016
44703	33	CHANGED DIMENSION KK FROM 201 TO 200 mm AND FROM 241 TO 236 mm;	TAB	KK	WG	05.01.2017

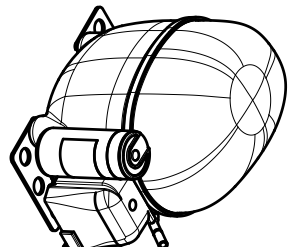
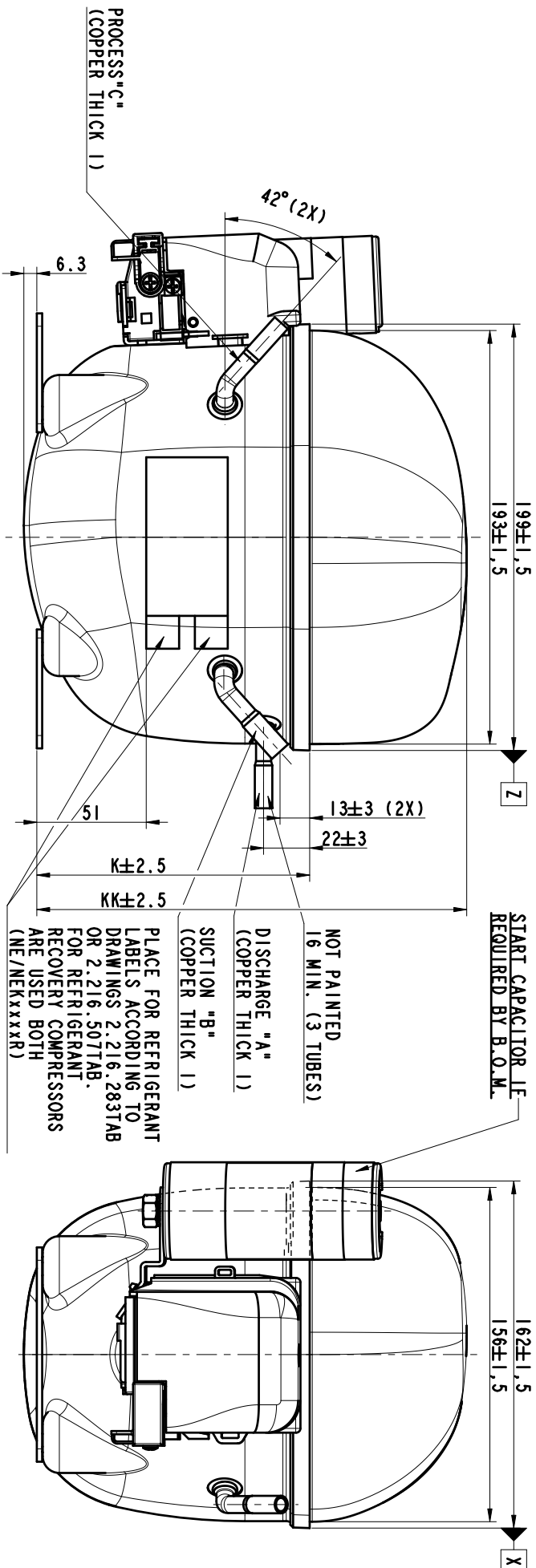

SCALE 1:5

CSIR, RSIR, RSCR

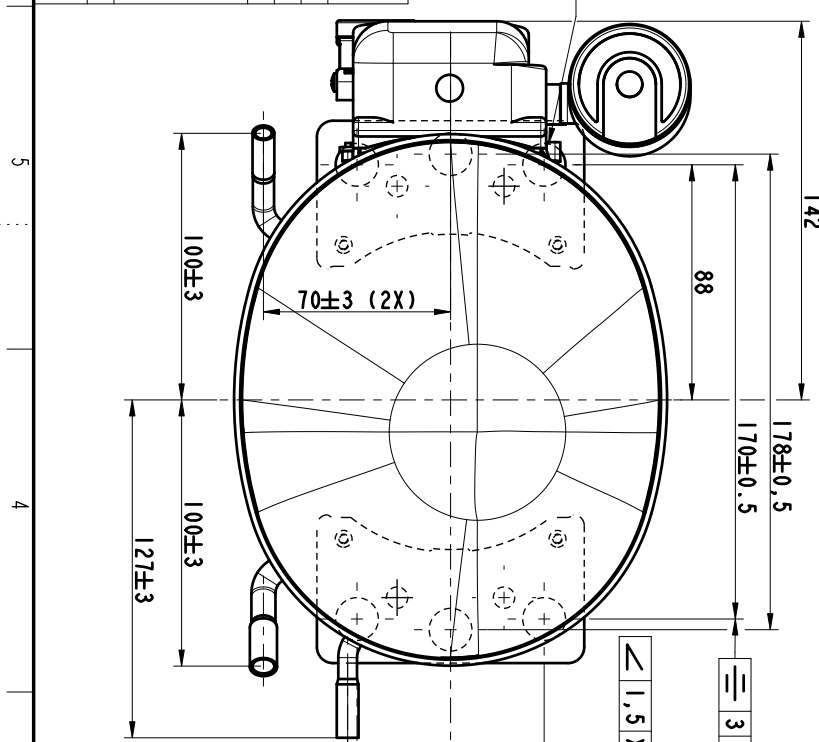

MATERIAL :

CODE :

DRAWN : TONELLA M.

APP. : MARTINO J.

ECM : 503723

06-10-2003

NAME

**embraco**

SHEET 1/3

EXTERNAL VIEW "NEK", "NBT", "NEU"

VISTA ESTERNA "NEK", "NBT", "NEU"

EXTERNÝ POHĽAD "NEK", "NBT", "NEU"

GEN. TOL. :

ANG. TOL. :

SCALE : 1:2

REPLACE

No. 1.960.853

THIS MATERIAL IS SUPPLIED AS IS AND IS NOT TO BE USED IN ANY APPLICATION WHERE THE USER'S SAFETY OR THE SAFETY OF OTHERS DEPENDS ON THE PROPER USE OF THE PRODUCT. THE USER SHALL BE RESPONSIBLE FOR THE PROPER USE OF THE PRODUCT.

ECM	REVISION	LO	BY	APP	DATE	
33471	25	ADDED NEW MODEL NEUR214Z	TAB	LF	WG	11.04.2014
33788	26	ADDED NEW MODEL NEUR214U	TAB	LK	WG	07.05.2014
34098	27	ADDED MODELS NEUR214G6, NEUR21556	TAB	LF	WG	02.06.2014
32548	28	ADDED MODELS NEUR210Z, NEUR212Z, NEUR2148A, NEUR210U ADDED "NEU" TO THE DESCRIPTION	TAB	MR	LF	22.9.2014
37454	29	ADDED NOTE: CSIR, RSIR, RSCR TO PG.1; ADDED PAGE 2 - CSR CONFIGURATION; MODELS NEUR210U, NEUR212U, NEUR2148A, NEUR21556 MOVED FROM PG.1 TO PG.2; CHANGE POSITION OF REFRIGERANT LABEL - PG.3.	E6 TAB KK BA	RR	RR	11.03.2015
35759	30	ADDED MODEL NEUR187Z	TAB	WP	WG	10.06.2015
38932	31	ADDED SHELL TYPE R10.32 AND MODEL NEU111Z	TAB	WG	RR	12.01.2016
31531	32	ADDED MODELS NEUR220U, NEUR212U, NEUR2206; MODEL TABLES MOVED TO SHEET 3; SHEET 3 REMOVED;	TAB	PS	WG	05.10.2016
44703	33	CHANGED DIMENSION KK FROM 201 TO 200 mm AND FROM 241 TO 236 mm.	TAB	KK	WG	05.01.2017

Ø 16<sup>+0,25</sup> (6 HOLES)

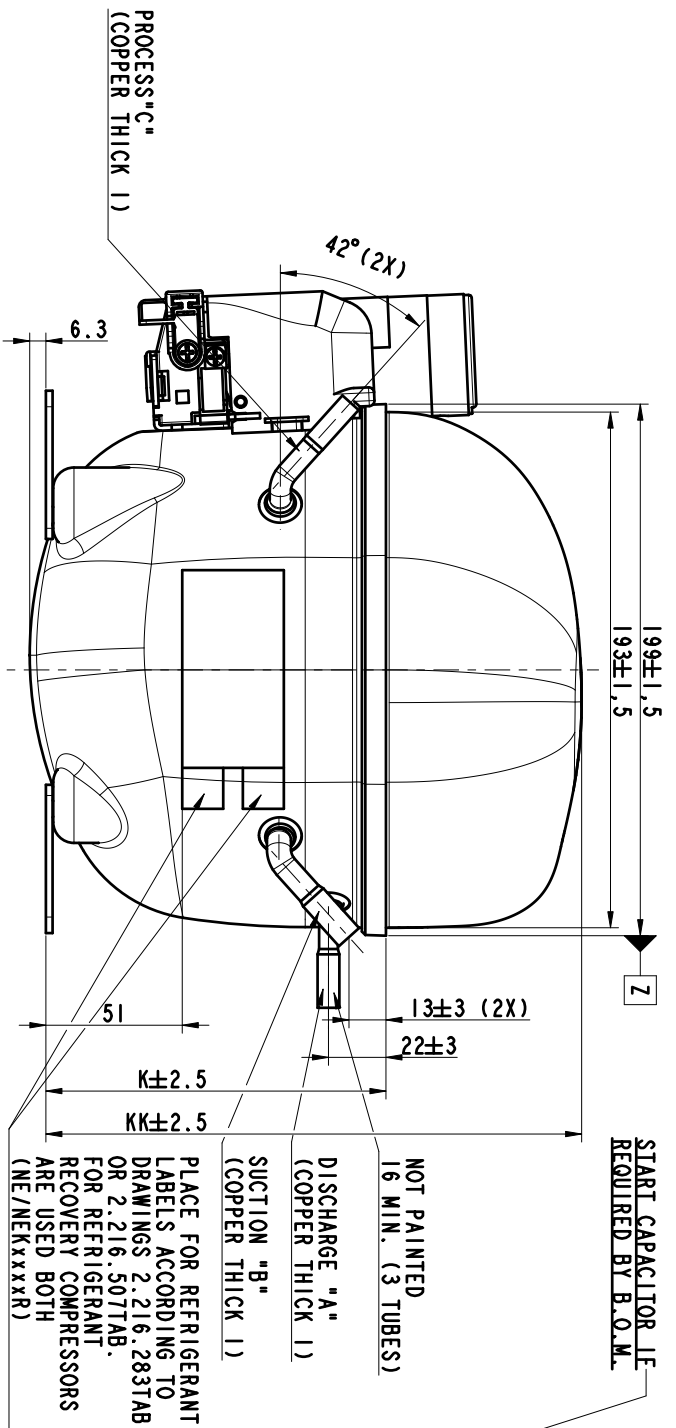
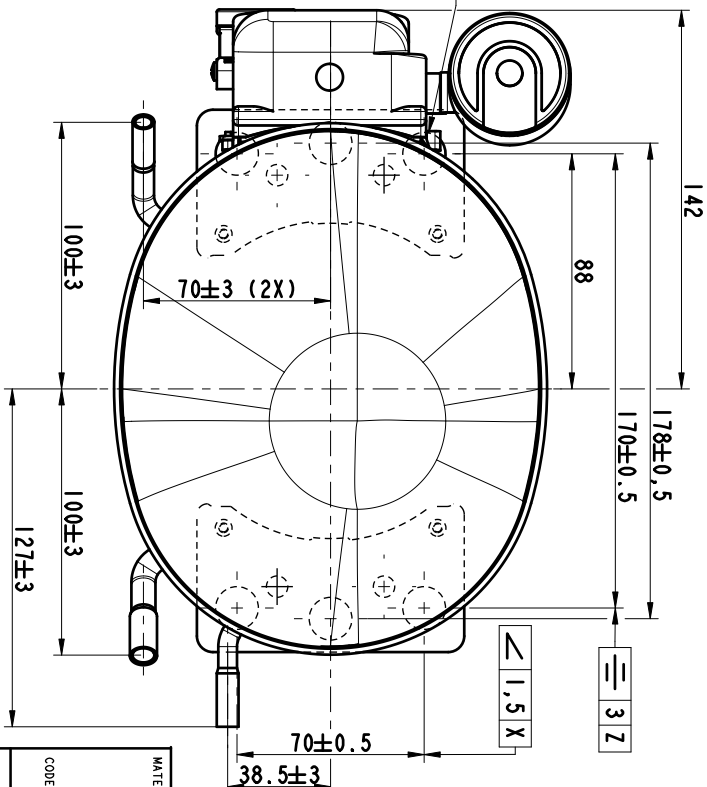

START CAPACITOR LE  
REQUIRED BY B.O.M.

NOT PAINTED  
16 MIN. (3 TUBES)

DISCHARGE "A"  
(COPPER THICK 1)

SUCTION "B"  
(COPPER THICK 1)

PLACE FOR REFRIGERANT  
LABELS ACCORDING TO  
DRAWINGS 2.216.507TAB,  
OR 2.216.507TAB.  
FOR REFRIGERANT  
RECOVERY COMPRESSORS  
ARE USED BOTH  
(NE/NEKxxxxR)

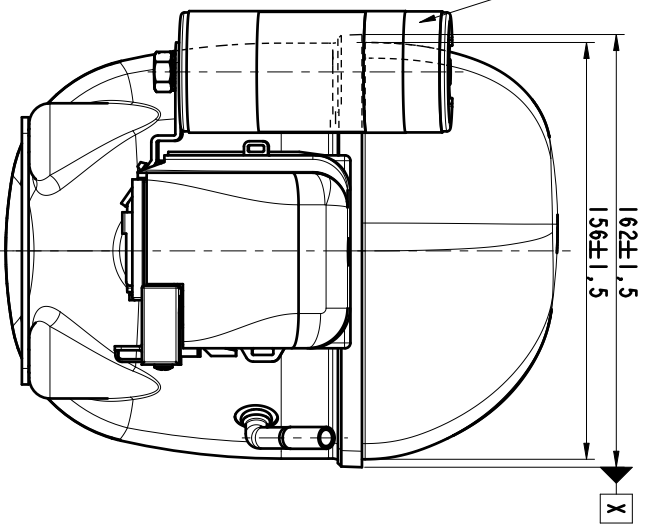

CSIR, RSIR, RSCR

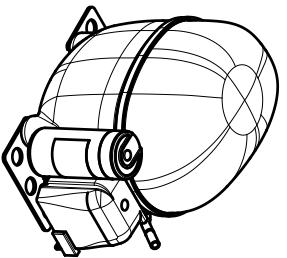

SCALE 1:5

MATERIAL :		DRAWN : TONELLA M.	
CODE :		APP. : MARTINO J.	
DATE :		06-10-2003	
ECM : 503723		THIS MATERIAL IS SPECIALLY TREATED AND PROTECTED TO EMBRACO PURPOSE AND ANY USE OF IT IS LIMITED TO THE ORIGINAL INTENTION.	
<p><b>embraco</b></p> <p>SHEET 1/3</p> <p>EXTERNAL VIEW "NEK", "NBT", "NEU" VISTA ESTERNA "NEK", "NBT", "NEU" EXTERNY POHLAD "NEK", "NBT", "NEU"</p>		GEN. TOL. :	
		ANG. TOL. :	
SCALE :		1:2	
REPLACE		No.	
		1.960.853	