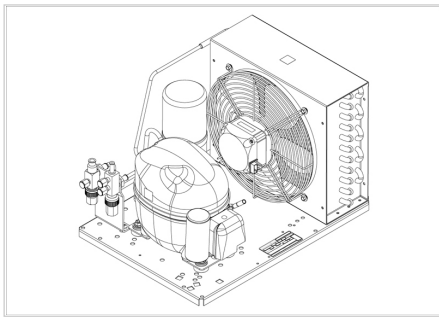

MODEL

UNEK2150GK**embraco**

CE

ENGINEERING CODE
559AA8212AA

APPROVED REFRIGERANT
R452A

POWER SUPPLY
220 - 240V 50Hz ~

STANDARD CONDITIONS
EN13215_SH10

APPLICATION
LBP

COOLING CAPACITY
248 W

EFFICIENCY
0.63 W/W

DATA

General Data

Weight	21.6 Kg
Receiver	1.1 L
Height	296 mm
Length	465 mm
Width	340 mm
Power Supply	220 - 240 V 50 Hz

Electrical Data

Motor Type	CSIR
Locked Rotor Amperage (LRA)	19.5 A
Max Current	3.52 A

Components

Condenser	3R11T	2451206
Fan Kit	16W 254/28/5B	1996610
Valve Suction	FLARE 3/8"	2110059
Valve Discharge	FLARE 1/4"	2110085
Compressor	NEK2150GK	959AA51...AM
Electrical Kit	ELKOM NEK2150GK	959AA51N1A

Noise Data

Sound Power Level	64.3 dB (A)	-	-
Sound Pressure Level	at 1 m	at 5 m	at 10 m
	56.3 dB (A)	42.4 dB (A)	36.3 dB (A)

Fan Motor

Number	1
Shaft Power	16 W
Air Flow	595 m ³ /h
Blade diameter	254 mm

PERFORMANCE

Rated Points

Ambient Temperature	Cooling Capacity	Power Consumption	Current	Efficiency
32.00°C	248 W	394 W	0.82 A	0.63 W/W

Test Condition: EN13215_SH10, Return Gas 0 °C, Subcooling OK , Evaporation -35.00°C, Condensing 0 °C, Ambient 32.00°C

Performance Curve Data

Ambient Temperature 25°C

Evaporating Temperature °C	Cooling Capacity W	Power Consumption W	Current A	Efficiency W/W
-40	211	341	0.68	0.62
-35	310	385	0.81	0.8
-30	409	434	0.92	0.94
-25	515	488	1.01	1.06
-20	632	546	1.1	1.16
-15	768	610	1.19	1.26
-10	928	680	1.29	1.36

Test Condition: EN13215_SH10, LBP

Ambient Temperature 32°C

Evaporating Temperature °C	Cooling Capacity W	Power Consumption W	Current A	Efficiency W/W
-40	155	352	0.69	0.44
-35	248	394	0.82	0.63
-30	343	442	0.93	0.78
-25	447	495	1.03	0.9
-20	565	554	1.12	1.02
-15	703	621	1.21	1.13
-10	867	694	1.3	1.25

Test Condition: EN13215_SH10, LBP

Ambient Temperature 43°C

Evaporating Temperature °C	Cooling Capacity W	Power Consumption W	Current A	Efficiency W/W
-40	136	367	0.73	0.37
-35	196	411	0.87	0.48
-30	261	462	0.99	0.57
-25	338	520	1.09	0.65
-20	432	586	1.18	0.74
-15	549	660	1.27	0.83
-10	694	742	1.37	0.94

Test Condition: EN13215_SH10, LBP

Operating Envelope

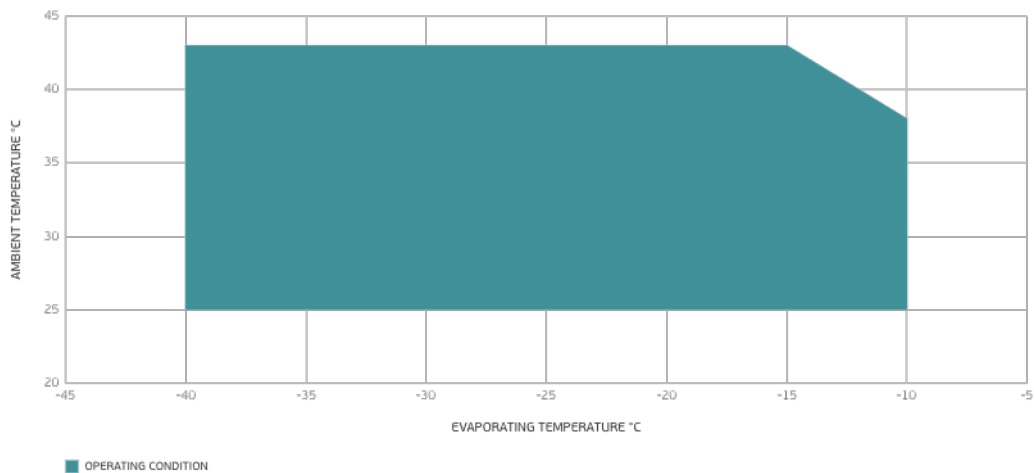

External Dimensions

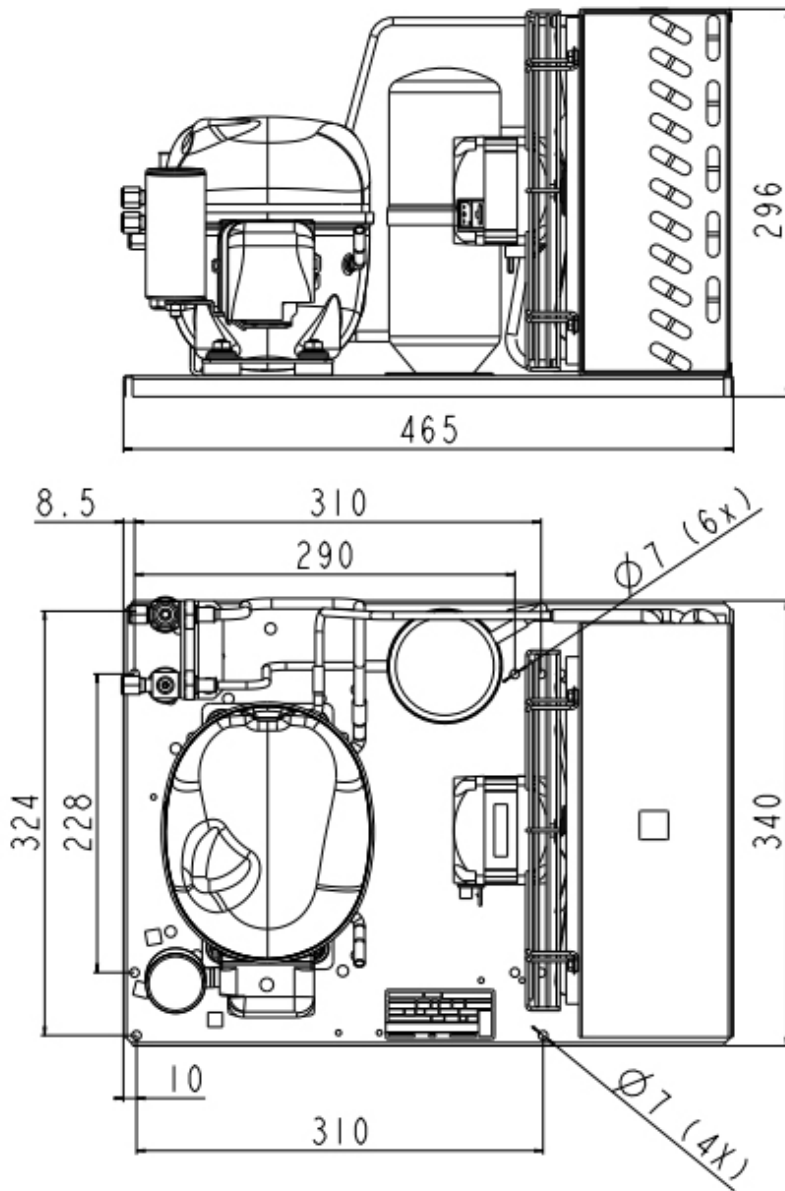

Wiring Diagram

