

MODEL

UNJ2212GK

embraco

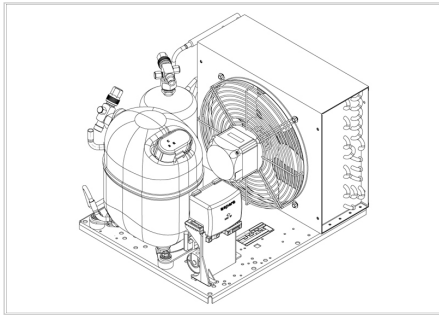

CE

ENGINEERING CODE
643TA5604AA

APPROVED REFRIGERANT
R452A

POWER SUPPLY
220 - 240V 50Hz ~

STANDARD CONDITIONS
EN13215_SH10

APPLICATION
LBP

COOLING CAPACITY
619 W

EFFICIENCY
0.75 W/W

DATA

General Data

Weight	38.3 Kg
Receiver	2.3 L
Height	324 mm
Length	481 mm
Width	410 mm
Power Supply	220 - 240 V 50 Hz

Electrical Data

Motor Type	CSR
Locked Rotor Amperage (LRA)	36 A
Max Current	6.5 A

Components

Condenser	3R12T	2451140
Fan Kit	34W 275/31/5B	1996583
Valve Discharge	SOLDER 3/8"	2110049
Valve Suction	SOLDER 5/8"	2110054
Compressor	NJ2212GK	943DA19..AC
Electrical Kit	ELKOM NJ2212GK	943DA1904A

Noise Data

Sound Power Level	71.3 dB (A)	-	-
Sound Pressure Level	at 1 m	at 5 m	at 10 m
	63.30327879 dB (A)	49.3238787 dB (A)	43.30327879 dB (A)

Fan Motor

Number	1
Shaft Power	34 W
Air Flow	800 m ³ /h
Blade diameter	275 mm

PERFORMANCE

Rated Points

Ambient Temperature	Cooling Capacity	Power Consumption	Current	Efficiency
32.00°C	619 W	828 W	4.57 A	0.75 W/W

Test Condition: EN13215_SH10, Return Gas 0 °C, Subcooling OK , Evaporation -35.00°C, Condensing 0 °C, Ambient 32.00°C

Performance Curve Data

Ambient Temperature 25°C

Evaporating Temperature °C	Cooling Capacity W	Power Consumption W	Current A	Efficiency W/W
-40	575	739	4.22	0.78
-35	795	853	4.68	0.93
-30	1043	983	5.22	1.06
-25	1319	1131	5.86	1.17
-20	1623	1299	6.59	1.25
-15	1957	1486	7.44	1.32
-10	2320	1695	8.39	1.37

Test Condition: EN13215_SH10, LBP

Ambient Temperature 32°C

Evaporating Temperature °C	Cooling Capacity W	Power Consumption W	Current A	Efficiency W/W
-40	426	700	4.07	0.61
-35	619	828	4.57	0.75
-30	841	973	5.16	0.86
-25	1090	1135	5.86	0.96
-20	1368	1316	6.66	1.04
-15	1675	1518	7.58	1.1
-10	2012	1741	8.62	1.16

Test Condition: EN13215_SH10, LBP

Ambient Temperature 43°C

Evaporating Temperature °C	Cooling Capacity W	Power Consumption W	Current A	Efficiency W/W
-40	280	671	4.03	0.42
-35	440	815	4.55	0.54
-30	628	975	5.19	0.64
-25	845	1153	5.93	0.73
-20	1090	1350	6.8	0.81
-15	1364	1566	7.8	0.87
-10	1668	1805	8.94	0.92

Test Condition: EN13215_SH10, LBP

Operating Envelope

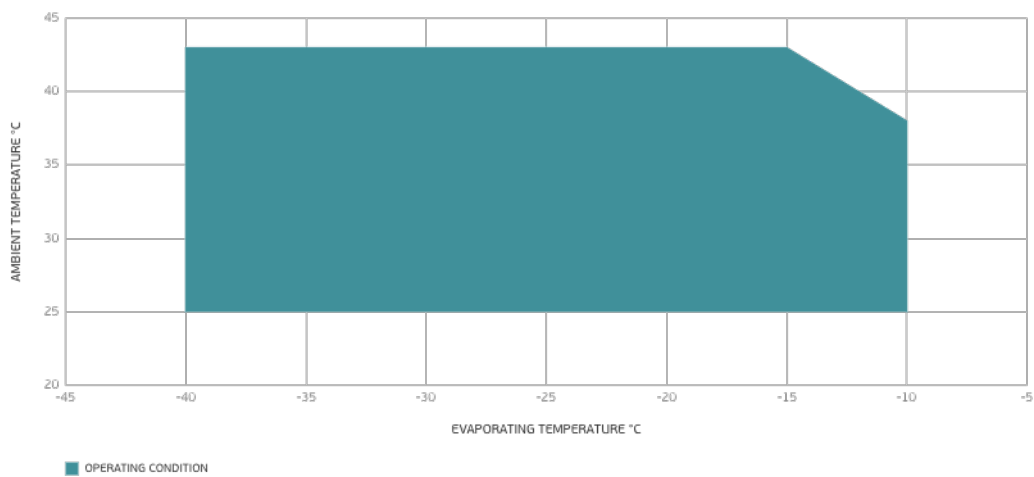

External Dimensions

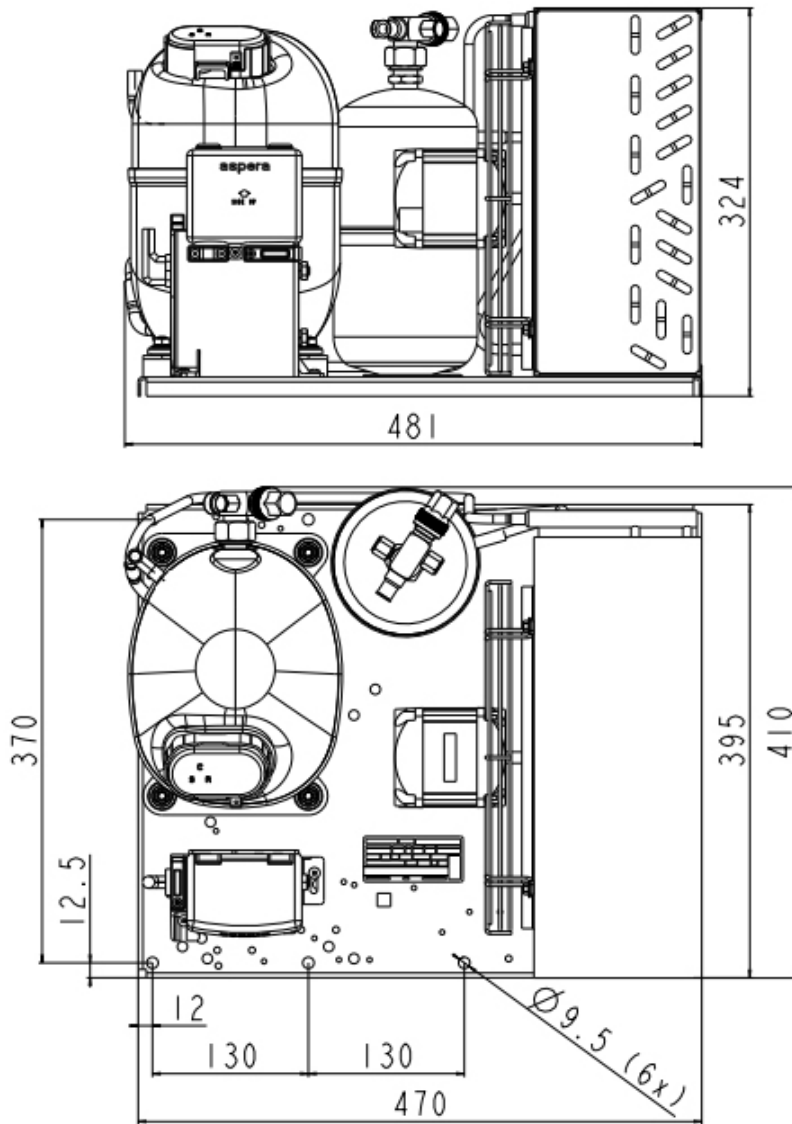

Wiring Diagram

