

MODEL

UNT622GK

embraco

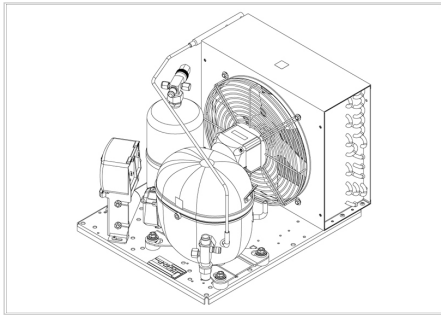

CE

ENGINEERING CODE
602CA5204AA

APPROVED REFRIGERANT
R449A

POWER SUPPLY
220 - 240V 50Hz ~

STANDARD CONDITIONS
EN13215_SH10

APPLICATION
M/HBP

COOLING CAPACITY
1373 W

EFFICIENCY
1.77 W/W

DATA

General Data

Weight	31.3 Kg
Receiver	2.3 L
Height	324 mm
Length	494 mm
Width	395 mm
Power Supply	220 - 240 V 50 Hz

Electrical Data

Motor Type	CSR
Locked Rotor Amperage (LRA)	30 A
Max Current	7.73 A

Components

Condenser	3R12T	2451140
Fan Kit	34W 275/31/5B	1996583
Valve Discharge	FLARE 3/8"	2110056
Valve Suction	FLARE 1/2"	2110057
Electrical Kit	ELKOM NT6222GK	922CA0404A
Compressor	NT6222GK	922CA09..AC

Noise Data

Sound Power Level	70.5 dB (A)	-	-
Sound Pressure Level	at 1 m	at 5 m	at 10 m
	62.4976018 dB (A)	48.51820171 dB (A)	42.4976018 dB (A)

Fan Motor

Number	1
Shaft Power	34 W
Air Flow	640 m ³ /h
Blade diameter	275 mm

PERFORMANCE

Rated Points

Ambient Temperature	Cooling Capacity	Power Consumption	Current	Efficiency
32.00°C	1373 W	777 W	4.28 A	1.77 W/W

Test Condition: EN13215_SH10, Return Gas 0 °C, Subcooling 0K , Evaporation -10.00°C, Condensing 0 °C, Ambient 32.00°C

Performance Curve Data

Ambient Temperature 25°C

Evaporating Temperature °C	Cooling Capacity W	Power Consumption W	Current A	Efficiency W/W
-20	700	636	3.73	1.1
-15	950	703	3.97	1.35
-10	1254	770	4.22	1.63
-5	1601	837	4.49	1.91
0	1977	909	4.79	2.17
5	2371	988	5.12	2.4
10	2770	1076	5.51	2.58

Test Condition: EN13215_SH10, M/HBP

Ambient Temperature 32°C

Evaporating Temperature °C	Cooling Capacity W	Power Consumption W	Current A	Efficiency W/W
-20	878	634	3.74	1.38
-15	1104	705	4.01	1.57
-10	1373	777	4.28	1.77
-5	1673	851	4.58	1.96
0	1991	931	4.91	2.14
5	2314	1018	5.28	2.27
10	2631	1116	5.72	2.36

Test Condition: EN13215_SH10, M/HBP

Ambient Temperature 43°C

Evaporating Temperature °C	Cooling Capacity W	Power Consumption W	Current A	Efficiency W/W
-20	487	661	3.82	0.74
-15	716	738	4.12	0.97
-10	969	818	4.43	1.18
-5	1234	902	4.78	1.37
0	1500	994	5.17	1.51
5	1753	1095	5.62	1.6
10	1980	1209	6.14	1.64

Test Condition: EN13215_SH10, M/HBP

Operating Envelope

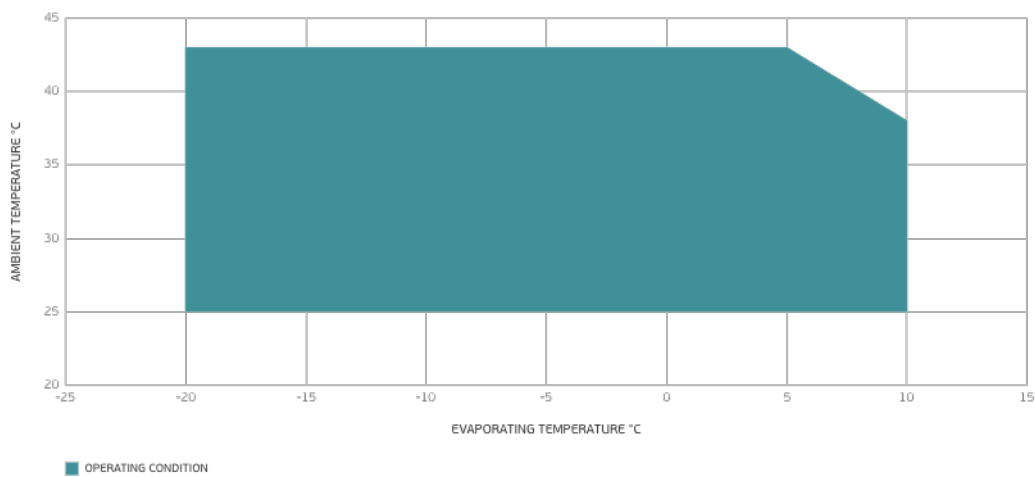

External Dimensions

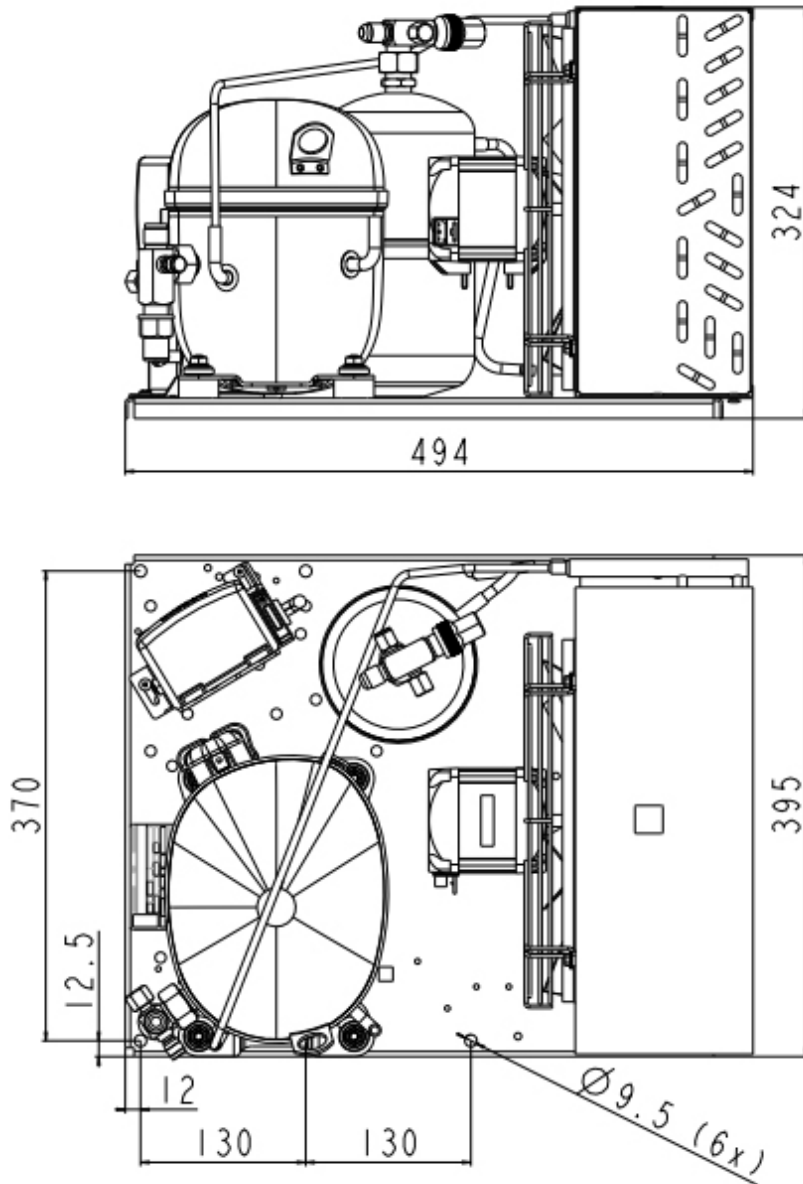

Wiring Diagram

